

# Python code for Artificial Intelligence

## Foundations of Computational Agents

David L. Poole and Alan K. Mackworth

Version 0.9.12 of January 18, 2024.

<https://aipython.org> <https://artint.info>

©David L Poole and Alan K Mackworth 2017-2023.

All code is licensed under a Creative Commons Attribution-NonCommercial-ShareAlike 4.0 International License. See: <https://creativecommons.org/licenses/by-nc-sa/4.0/deed.en>

This document and all the code can be downloaded from  
<https://artint.info/AIPython/> or from <https://aipython.org>

The authors and publisher of this book have used their best efforts in preparing this book. These efforts include the development, research and testing of the theories and programs to determine their effectiveness. The authors and publisher make no warranty of any kind, expressed or implied, with regard to these programs or the documentation contained in this book. The author and publisher shall not be liable in any event for incidental or consequential damages in connection with, or arising out of, the furnishing, performance, or use of these programs.



# Contents

<b>Contents</b>	<b>3</b>
<b>1 Python for Artificial Intelligence</b>	<b>9</b>
1.1 Why Python? . . . . .	9
1.2 Getting Python . . . . .	10
1.3 Running Python . . . . .	10
1.4 Pitfalls . . . . .	11
1.5 Features of Python . . . . .	11
1.5.1 f-strings . . . . .	11
1.5.2 Lists, Tuples, Sets, Dictionaries and Comprehensions . .	12
1.5.3 Functions as first-class objects . . . . .	13
1.5.4 Generators . . . . .	14
1.6 Useful Libraries . . . . .	16
1.6.1 Timing Code . . . . .	16
1.6.2 Plotting: Matplotlib . . . . .	16
1.7 Utilities . . . . .	18
1.7.1 Display . . . . .	18
1.7.2 Argmax . . . . .	19
1.7.3 Probability . . . . .	20
1.8 Testing Code . . . . .	21
<b>2 Agent Architectures and Hierarchical Control</b>	<b>25</b>
2.1 Representing Agents and Environments . . . . .	25
2.2 Paper buying agent and environment . . . . .	27
2.2.1 The Environment . . . . .	27
2.2.2 The Agent . . . . .	29

2.2.3	Plotting . . . . .	29
2.3	Hierarchical Controller . . . . .	31
2.3.1	Environment . . . . .	31
2.3.2	Body . . . . .	32
2.3.3	Middle Layer . . . . .	34
2.3.4	Top Layer . . . . .	35
2.3.5	Plotting . . . . .	36
<b>3</b>	<b>Searching for Solutions</b>	<b>41</b>
3.1	Representing Search Problems . . . . .	41
3.1.1	Explicit Representation of Search Graph . . . . .	43
3.1.2	Paths . . . . .	45
3.1.3	Example Search Problems . . . . .	47
3.2	Generic Searcher and Variants . . . . .	53
3.2.1	Searcher . . . . .	53
3.2.2	GUI for Tracing Search . . . . .	55
3.2.3	Frontier as a Priority Queue . . . . .	59
3.2.4	$A^*$ Search . . . . .	60
3.2.5	Multiple Path Pruning . . . . .	62
3.3	Branch-and-bound Search . . . . .	64
<b>4</b>	<b>Reasoning with Constraints</b>	<b>69</b>
4.1	Constraint Satisfaction Problems . . . . .	69
4.1.1	Variables . . . . .	69
4.1.2	Constraints . . . . .	70
4.1.3	CSPs . . . . .	71
4.1.4	Examples . . . . .	74
4.2	A Simple Depth-first Solver . . . . .	83
4.3	Converting CSPs to Search Problems . . . . .	84
4.4	Consistency Algorithms . . . . .	86
4.4.1	Direct Implementation of Domain Splitting . . . . .	89
4.4.2	Consistency GUI . . . . .	91
4.4.3	Domain Splitting as an interface to graph searching . . . . .	93
4.5	Solving CSPs using Stochastic Local Search . . . . .	95
4.5.1	Any-conflict . . . . .	97
4.5.2	Two-Stage Choice . . . . .	98
4.5.3	Updatable Priority Queues . . . . .	101
4.5.4	Plotting Run-Time Distributions . . . . .	102
4.5.5	Testing . . . . .	103
4.6	Discrete Optimization . . . . .	105
4.6.1	Branch-and-bound Search . . . . .	106
<b>5</b>	<b>Propositions and Inference</b>	<b>109</b>
5.1	Representing Knowledge Bases . . . . .	109
5.2	Bottom-up Proofs (with askables) . . . . .	112

- 5.3 Top-down Proofs (with askables) . . . . . 114
- 5.4 Debugging and Explanation . . . . . 115
- 5.5 Assumables . . . . . 119
- 5.6 Negation-as-failure . . . . . 122
  
- 6 Deterministic Planning . . . . . 125**
- 6.1 Representing Actions and Planning Problems . . . . . 125
  - 6.1.1 Robot Delivery Domain . . . . . 126
  - 6.1.2 Blocks World . . . . . 128
- 6.2 Forward Planning . . . . . 130
  - 6.2.1 Defining Heuristics for a Planner . . . . . 132
- 6.3 Regression Planning . . . . . 135
  - 6.3.1 Defining Heuristics for a Regression Planner . . . . . 137
- 6.4 Planning as a CSP . . . . . 138
- 6.5 Partial-Order Planning . . . . . 142
  
- 7 Supervised Machine Learning . . . . . 149**
- 7.1 Representations of Data and Predictions . . . . . 150
  - 7.1.1 Creating Boolean Conditions from Features . . . . . 153
  - 7.1.2 Evaluating Predictions . . . . . 155
  - 7.1.3 Creating Test and Training Sets . . . . . 157
  - 7.1.4 Importing Data From File . . . . . 157
  - 7.1.5 Augmented Features . . . . . 160
- 7.2 Generic Learner Interface . . . . . 162
- 7.3 Learning With No Input Features . . . . . 163
  - 7.3.1 Evaluation . . . . . 165
- 7.4 Decision Tree Learning . . . . . 167
- 7.5 Cross Validation and Parameter Tuning . . . . . 171
- 7.6 Linear Regression and Classification . . . . . 175
- 7.7 Boosting . . . . . 181
  - 7.7.1 Gradient Tree Boosting . . . . . 184
  
- 8 Neural Networks and Deep Learning . . . . . 187**
- 8.1 Layers . . . . . 187
  - 8.1.1 Linear Layer . . . . . 188
  - 8.1.2 ReLU Layer . . . . . 190
  - 8.1.3 Sigmoid Layer . . . . . 190
- 8.2 Feedforward Networks . . . . . 191
- 8.3 Improved Optimization . . . . . 193
  - 8.3.1 Momentum . . . . . 193
  - 8.3.2 RMS-Prop . . . . . 193
- 8.4 Dropout . . . . . 194
  - 8.4.1 Examples . . . . . 195
  
- 9 Reasoning with Uncertainty . . . . . 201**

9.1	Representing Probabilistic Models . . . . .	201
9.2	Representing Factors . . . . .	201
9.3	Conditional Probability Distributions . . . . .	203
9.3.1	Logistic Regression . . . . .	203
9.3.2	Noisy-or . . . . .	204
9.3.3	Tabular Factors and Prob . . . . .	205
9.3.4	Decision Tree Representations of Factors . . . . .	206
9.4	Graphical Models . . . . .	208
9.4.1	Showing Belief Networks . . . . .	209
9.4.2	Example Belief Networks . . . . .	210
9.5	Inference Methods . . . . .	216
9.5.1	Showing Posterior Distributions . . . . .	217
9.6	Naive Search . . . . .	218
9.7	Recursive Conditioning . . . . .	220
9.8	Variable Elimination . . . . .	224
9.9	Stochastic Simulation . . . . .	227
9.9.1	Sampling from a discrete distribution . . . . .	227
9.9.2	Sampling Methods for Belief Network Inference . . . . .	229
9.9.3	Rejection Sampling . . . . .	229
9.9.4	Likelihood Weighting . . . . .	230
9.9.5	Particle Filtering . . . . .	231
9.9.6	Examples . . . . .	233
9.9.7	Gibbs Sampling . . . . .	234
9.9.8	Plotting Behavior of Stochastic Simulators . . . . .	236
9.10	Hidden Markov Models . . . . .	238
9.10.1	Exact Filtering for HMMs . . . . .	240
9.10.2	Localization . . . . .	241
9.10.3	Particle Filtering for HMMs . . . . .	244
9.10.4	Generating Examples . . . . .	246
9.11	Dynamic Belief Networks . . . . .	247
9.11.1	Representing Dynamic Belief Networks . . . . .	247
9.11.2	Unrolling DBNs . . . . .	250
9.11.3	DBN Filtering . . . . .	251
<b>10</b>	<b>Learning with Uncertainty</b>	<b>253</b>
10.1	Bayesian Learning . . . . .	253
10.2	K-means . . . . .	257
10.3	EM . . . . .	261
<b>11</b>	<b>Causality</b>	<b>267</b>
11.1	Do Questions . . . . .	267
11.2	Counterfactual Example . . . . .	269
11.2.1	Firing Squad Example . . . . .	271
<b>12</b>	<b>Planning with Uncertainty</b>	<b>275</b>

12.1	Decision Networks . . . . .	275
12.1.1	Example Decision Networks . . . . .	277
12.1.2	Decision Functions . . . . .	283
12.1.3	Recursive Conditioning for decision networks . . . . .	284
12.1.4	Variable elimination for decision networks . . . . .	287
12.2	Markov Decision Processes . . . . .	289
12.2.1	Problem Domains . . . . .	291
12.2.2	Value Iteration . . . . .	299
12.2.3	Value Iteration GUI for Grid Domains . . . . .	300
12.2.4	Asynchronous Value Iteration . . . . .	302
<b>13</b>	<b>Reinforcement Learning</b>	<b>307</b>
13.1	Representing Agents and Environments . . . . .	307
13.1.1	Environments . . . . .	307
13.1.2	Agents . . . . .	308
13.1.3	Simulating an Environment-Agent Interaction . . . . .	309
13.1.4	Party Environment . . . . .	310
13.1.5	Environment from a Problem Domain . . . . .	311
13.1.6	Monster Game Environment . . . . .	312
13.2	Q Learning . . . . .	315
13.2.1	Exploration Strategies . . . . .	317
13.2.2	Testing Q-learning . . . . .	318
13.3	Q-leaning with Experience Replay . . . . .	320
13.4	Stochastic Policy Learning Agent . . . . .	322
13.5	Model-based Reinforcement Learner . . . . .	324
13.6	Reinforcement Learning with Features . . . . .	327
13.6.1	Representing Features . . . . .	328
13.6.2	Feature-based RL learner . . . . .	331
13.7	GUI for RL . . . . .	334
<b>14</b>	<b>Multiagent Systems</b>	<b>339</b>
14.1	Minimax . . . . .	339
14.1.1	Creating a two-player game . . . . .	339
14.1.2	Minimax and $\alpha$ - $\beta$ Pruning . . . . .	342
14.2	Multiagent Learning . . . . .	344
14.2.1	Simulating Multiagent Interaction with an Environment . . . . .	344
14.2.2	Example Games . . . . .	346
14.2.3	Testing Games and Environments . . . . .	347
<b>15</b>	<b>Individuals and Relations</b>	<b>349</b>
15.1	Representing Datalog and Logic Programs . . . . .	349
15.2	Unification . . . . .	351
15.3	Knowledge Bases . . . . .	352
15.4	Top-down Proof Procedure . . . . .	354
15.5	Logic Program Example . . . . .	356

<b>16 Knowledge Graphs and Ontologies</b>	<b>359</b>
16.1 Triple Store . . . . .	359
16.2 Integrating Datalog and Triple Store . . . . .	362
<b>17 Relational Learning</b>	<b>365</b>
17.1 Collaborative Filtering . . . . .	365
17.1.1 Plotting . . . . .	369
17.1.2 Loading Rating Sets from Files and Websites . . . . .	372
17.1.3 Ratings of top items and users . . . . .	373
17.2 Relational Probabilistic Models . . . . .	375
<b>18 Version History</b>	<b>381</b>
<b>Bibliography</b>	<b>383</b>
<b>Index</b>	<b>385</b>

## Python for Artificial Intelligence

AIPython contains runnable code for the book *Artificial Intelligence, foundations of computational agents, 3rd Edition* [Poole and Mackworth, 2023]. It has the following design goals:

- Readability is more important than efficiency, although the asymptotic complexity is not compromised. AIPython is not a replacement for well-designed libraries, or optimized tools. Think of it like a model of an engine made of glass, so you can see the inner workings; don't expect it to power a big truck, but it lets you see how a metal engine can power a truck.
- It uses as few libraries as possible. A reader only needs to understand Python. Libraries hide details that we make explicit. The only library used is matplotlib for plotting and drawing.

### 1.1 Why Python?

We use Python because Python programs can be close to pseudo-code. It is designed for humans to read.

Python is reasonably efficient. Efficiency is usually not a problem for small examples. If your Python code is not efficient enough, a general procedure to improve it is to find out what is taking most of the time, and implement just that part more efficiently in some lower-level language. Most of these lower-level languages interoperate with Python nicely. This will result in much less programming and more efficient code (because you will have more time to optimize) than writing everything in a low-level language. You will not have to do that for the code here if you are using it for larger projects.

## 1.2 Getting Python

You need Python 3.9 or later (<https://python.org/>) and a compatible version of matplotlib (<https://matplotlib.org/>). This code is *not* compatible with Python 2 (e.g., with Python 2.7).

Download and install the latest Python 3 release from <https://python.org/> or <https://www.anaconda.com/download>. This should also install pip3. You can install matplotlib using

```
pip3 install matplotlib
```

in a terminal shell (not in Python). That should “just work”. If not, try using pip instead of pip3.

The command python or python3 should then start the interactive Python shell. You can quit Python with a control-D or with quit().

To upgrade matplotlib to the latest version (which you should do if you install a new version of Python) do:

```
pip3 install --upgrade matplotlib
```

We recommend using the enhanced interactive python **ipython** (<https://ipython.org/>) [Pérez and Granger, 2007]. To install ipython after you have installed python do:

```
pip3 install ipython
```

## 1.3 Running Python

We assume that everything is done with an interactive Python shell. You can either do this with an IDE, such as IDLE that comes with standard Python distributions, or just running ipython3 or python3 (or perhaps just ipython or python) from a shell.

Here we describe the most simple version that uses no IDE. If you download the zip file, and cd to the “aipython” folder where the .py files are, you should be able to do the following, with user input in bold. The first python command is in the operating system shell; the -i is important to enter interactive mode.

```
python -i searchGeneric.py
```

```
Testing problem 1:
```

```
7 paths have been expanded and 4 paths remain in the frontier
```

```
Path found: A --> C --> B --> D --> G
```

```
Passed unit test
```

```
>>> searcher2 = AStarSearcher(searchProblem.acyclic_delivery_problem) #A*
```

```
>>> searcher2.search() # find first path
```

```
16 paths have been expanded and 5 paths remain in the frontier
```

```
o103 --> o109 --> o119 --> o123 --> r123
```

```
>>> searcher2.search() # find next path
```

```

21 paths have been expanded and 6 paths remain in the frontier
o103 --> b3 --> b4 --> o109 --> o119 --> o123 --> r123
>>> searcher2.search() # find next path
28 paths have been expanded and 5 paths remain in the frontier
o103 --> b3 --> b1 --> b2 --> b4 --> o109 --> o119 --> o123 --> r123
>>> searcher2.search() # find next path
No (more) solutions. Total of 33 paths expanded.
>>>

```

You can then interact at the last prompt.

There are many textbooks for Python. The best source of information about python is <https://www.python.org/>. The documentation is at <https://docs.python.org/3/>.

The rest of this chapter is about what is special about the code for AI tools. We will only use the standard Python library and matplotlib. All of the exercises can be done (and should be done) without using other libraries; the aim is for you to spend your time thinking about how to solve the problem rather than searching for pre-existing solutions.

## 1.4 Pitfalls

It is important to know when side effects occur. Often AI programs consider what would/might happen given certain conditions. In many such cases, we don't want side effects. When an agent acts in the world, side effects are appropriate.

In Python, you need to be careful to understand side effects. For example, the inexpensive function to add an element to a list, namely `append`, changes the list. In a functional language like Haskell or Lisp, adding a new element to a list, without changing the original list, is a cheap operation. For example if  $x$  is a list containing  $n$  elements, adding an extra element to the list in Python (using `append`) is fast, but it has the side effect of changing the list  $x$ . To construct a new list that contains the elements of  $x$  plus a new element, without changing the value of  $x$ , entails copying the list, or using a different representation for lists. In the searching code, we will use a different representation for lists for this reason.

## 1.5 Features of Python

### 1.5.1 f-strings

Python can use matching `'`, `"`, `'''` or `"""`, the latter two respecting line breaks in the string. We use the convention that when the string denotes a unique symbol, we use single quotes, and when it is designed to be for printing, we use double quotes.

We make extensive use of f-strings <https://docs.python.org/3/tutorial/inputoutput.html>. In its simplest form

```
f"str1{e1}str2{e2}str3"
```

where *e1* and *e2* are expressions, is an abbreviation for

```
"str1"+str(e2)+"str2"+str(e2)+"str3"
```

where `+` is string concatenation, and `str` is the function that returns a string representation of its expression argument.

## 1.5.2 Lists, Tuples, Sets, Dictionaries and Comprehensions

We make extensive uses of lists, tuples, sets and dictionaries (dicts). See <https://docs.python.org/3/library/stdtypes.html>

One of the nice features of Python is the use of **comprehensions**<sup>1</sup> (and also list, tuple, set and dictionary comprehensions). A generator expression is of the form

```
(fe for e in iter if cond)
```

enumerates the values *fe* for each *e* in *iter* for which *cond* is true. The “if *cond*” part is optional, but the “for” and “in” are not optional. Here *e* is a variable (or a pattern that can be on the left side of `=`), *iter* is an iterator, which can generate a stream of data, such as a list, a set, a range object (to enumerate integers between ranges) or a file. *cond* is an expression that evaluates to either True or False for each *e*, and *fe* is an expression that will be evaluated for each value of *e* for which *cond* returns True.

The result can go in a list or used in another iteration, or can be called directly using `next`. The procedure `next` takes an iterator and returns the next element (advancing the iterator); it raises a `StopIteration` exception if there is no next element. The following shows a simple example, where user input is prepended with `>>>`

```
>>> [e*e for e in range(20) if e%2==0]
[0, 4, 16, 36, 64, 100, 144, 196, 256, 324]
>>> a = (e*e for e in range(20) if e%2==0)
>>> next(a)
0
>>> next(a)
4
>>> next(a)
16
>>> list(a)
[36, 64, 100, 144, 196, 256, 324]
```

<sup>1</sup><https://docs.python.org/3/reference/expressions.html#displays-for-lists-sets-and-dictionaries>

```
>>> next(a)
Traceback (most recent call last):
  File "<stdin>", line 1, in <module>
StopIteration
```

Notice how `list(a)` continued on the enumeration, and got to the end of it.

Comprehensions can also be used for dictionaries. The following code creates an index for list `a`:

```
>>> a = ["a", "f", "bar", "b", "a", "aaaaa"]
>>> ind = {a[i]:i for i in range(len(a))}
>>> ind
{'a': 4, 'f': 1, 'bar': 2, 'b': 3, 'aaaaa': 5}
>>> ind['b']
3
```

which means that `'b'` is the 3rd element of the list.

The assignment of `ind` could have also be written as:

```
>>> ind = {val:i for (i,val) in enumerate(a)}
```

where `enumerate` is a built-in function that, given a dictionary, returns an iterator of *(index, value)* pairs.

### 1.5.3 Functions as first-class objects

Python can create lists and other data structures that contain functions. There is an issue that tricks many newcomers to Python. For a local variable in a function, the function uses the last value of the variable when the function is *called*, not the value of the variable when the function was defined (this is called “late binding”). This means if you want to use the value a variable has when the function is created, you need to save the current value of that variable. Whereas Python uses “late binding” by default, the alternative that newcomers often expect is “early binding”, where a function uses the value a variable had when the function was defined. The following examples show how early binding can be implemented.

Consider the following programs designed to create a list of 5 functions, where the *i*th function in the list is meant to add *i* to its argument:<sup>2</sup>

```
pythonDemo.py — Some tricky examples
11 fun_list1 = []
12 for i in range(5):
13     def fun1(e):
14         return e+i
15     fun_list1.append(fun1)
```

<sup>2</sup>Numbered lines are Python code available in the code-directory, `aipython`. The name of the file is given in the gray text above the listing. The numbers correspond to the line numbers in that file.

```

16 |
17 | fun_list2 = []
18 | for i in range(5):
19 |     def fun2(e,iv=i):
20 |         return e+iv
21 |     fun_list2.append(fun2)
22 |
23 | fun_list3 = [lambda e: e+i for i in range(5)]
24 |
25 | fun_list4 = [lambda e,iv=i: e+iv for i in range(5)]
26 |
27 | i=56

```

Try to predict, and then test to see the output, of the output of the following calls, remembering that the function uses the latest value of any variable that is not bound in the function call:

```

pythonDemo.py — (continued)
29 | # in Shell do
30 | ## ipython -i pythonDemo.py
31 | # Try these (copy text after the comment symbol and paste in the Python
    | prompt):
32 | # print([f(10) for f in fun_list1])
33 | # print([f(10) for f in fun_list2])
34 | # print([f(10) for f in fun_list3])
35 | # print([f(10) for f in fun_list4])

```

In the first for-loop, the function fun1 uses *i*, whose value is the last value it was assigned. In the second loop, the function fun2 uses *iv*. There is a separate *iv* variable for each function, and its value is the value of *i* when the function was defined. Thus fun1 uses late binding, and fun2 uses early binding. fun\_list3 and fun\_list4 are equivalent to the first two (except fun\_list4 uses a different *i* variable).

One of the advantages of using the embedded definitions (as in fun1 and fun2 above) over the lambda is that it is possible to add a `__doc__` string, which is the standard for documenting functions in Python, to the embedded definitions.

### 1.5.4 Generators

Python has generators which can be used for a form of lazy evaluation – only computing values when needed.

The `yield` command returns a value that is obtained with `next`. It is typically used to enumerate the values for a for loop or in generators. (The `yield` command can also be used for coroutines, but AIPython only uses it for generators.)

A version of the built-in `range`, with 2 or 3 arguments (and positive steps) can be implemented as:

```

pythonDemo.py — (continued)
37 def myrange(start, stop, step=1):
38     """enumerates the values from start in steps of size step that are
39     less than stop.
40     """
41     assert step>0, f"only positive steps implemented in myrange: {step}"
42     i = start
43     while i<stop:
44         yield i
45         i += step
46
47 print("list(myrange(2,30,3)):", list(myrange(2,30,3)))

```

Note that the built-in `range` is unconventional in how it handles a single argument, as the single argument acts as the second argument of the function. Note also that the built-in `range` also allows for indexing (e.g., `range(2, 30, 3)[2]` returns 8), but the above implementation does not. However `myrange` also works for floats, whereas the built-in `range` does not.

**Exercise 1.1** Implement a version of `myrange` that acts like the built-in version when there is a single argument. (Hint: make the second argument have a default value that can be recognized in the function.) There is no need to make it with indexing.

Yield can be used to generate the same sequence of values as in the example of Section 1.5.2:

```

pythonDemo.py — (continued)
49 def ga(n):
50     """generates square of even nonnegative integers less than n"""
51     for e in range(n):
52         if e%2==0:
53             yield e*e
54 a = ga(20)

```

The sequence of `next(a)`, and `list(a)` gives exactly the same results as the comprehension in Section 1.5.2.

It is straightforward to write a version of the built-in `enumerate` called `myenumerate`:

```

pythonDemo.py — (continued)
56 def myenumerate(enum):
57     for i in range(len(enum)):
58         yield i,enum[i]

```

**Exercise 1.2** Write a version of `enumerate` where the only iteration is “for val in enum”. Hint: keep track of the index.

## 1.6 Useful Libraries

### 1.6.1 Timing Code

In order to compare algorithms, we often want to compute how long a program takes; this is called the **run time** of the program. The most straightforward way to compute run time is to use `time.perf_counter()`, as in:

```
import time
start_time = time.perf_counter()
compute_for_a_while()
end_time = time.perf_counter()
print("Time:", end_time - start_time, "seconds")
```

Note that `time.perf_counter()` measures clock time; so this should be done without user interaction between the calls. On the interactive python shell, you should do:

```
start_time = time.perf_counter(); compute_for_a_while(); end_time = time.perf_counter()
```

If this time is very small (say less than 0.2 second), it is probably very inaccurate, and it may be better to run your code many times to get a more accurate count. For this you can use `timeit` (<https://docs.python.org/3/library/timeit.html>). To use `timeit` to time the call to `foo.bar(aaa)` use:

```
import timeit
time = timeit.timeit("foo.bar(aaa)",
                    setup="from __main__ import foo,aaa", number=100)
```

The setup is needed so that Python can find the meaning of the names in the string that is called. This returns the number of seconds to execute `foo.bar(aaa)` 100 times. The variable number should be set so that the run time is at least 0.2 seconds.

You should not trust a single measurement as that can be confounded by interference from other processes. `timeit.repeat` can be used for running `timeit` a few (say 3) times. When reporting the time of any computation, you should be explicit and explain what you are reporting. Usually the minimum time is the one to report.

### 1.6.2 Plotting: Matplotlib

The standard plotting for Python is `matplotlib` (<https://matplotlib.org/>). We will use the most basic plotting using the `pyplot` interface.

Here is a simple example that uses everything we will use. The output is shown in Figure 1.1.

```
pythonDemo.py — (continued)
60 | import matplotlib.pyplot as plt
61 |
```

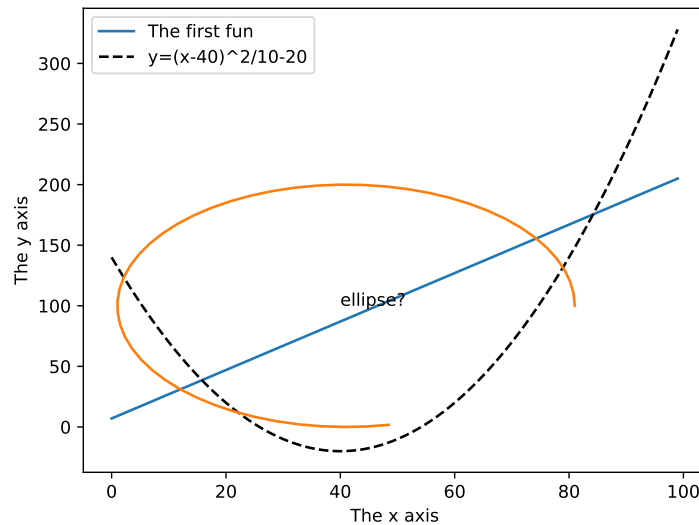

Figure 1.1: Result of pythonDemo code

```

62 def myplot(minv,maxv,step,fun1,fun2):
63     plt.ion() # make it interactive
64     plt.xlabel("The x axis")
65     plt.ylabel("The y axis")
66     plt.xscale('linear') # Makes a 'log' or 'linear' scale
67     xvalues = range(minv,maxv,step)
68     plt.plot(xvalues,[fun1(x) for x in xvalues],
69             label="The first fun")
70     plt.plot(xvalues,[fun2(x) for x in xvalues], linestyle='--',color='k',
71             label=fun2.__doc__) # use the doc string of the function
72     plt.legend(loc="upper right") # display the legend
73
74 def slin(x):
75     """y=2x+7"""
76     return 2*x+7
77 def sqfun(x):
78     """y=(x-40)^2/10-20"""
79     return (x-40)**2/10-20
80
81 # Try the following:
82 # from pythonDemo import myplot, slin, sqfun
83 # import matplotlib.pyplot as plt
84 # myplot(0,100,1,slin,sqfun)
85 # plt.legend(loc="best")
86 # import math
87 # plt.plot([41+40*math.cos(th/10) for th in range(50)],
88 #          [100+100*math.sin(th/10) for th in range(50)])

```

```
89 | # plt.text(40,100,"ellipse?")
90 | # plt.xscale('log')
```

At the end of the code are some commented-out commands you should try in interactive mode. Cut from the file and paste into Python (and remember to remove the comments symbol and leading space).

## 1.7 Utilities

### 1.7.1 Display

In this distribution, to keep things simple, using only standard Python, we use a text-oriented tracing of the code. A graphical depiction of the code can override the definition of `display` (e.g., see `SearcherGUI` in Section 3.2.2 and `ConsistencyGUI` in Section 4.4.2).

The method `self.display` is used to trace the program. Any call

```
self.display(level, to_print...)
```

where the *level* is less than or equal to the value for `max_display_level` will be printed. The *to\_print*... can be anything that is accepted by the built-in `print` (including any keyword arguments).

The definition of `display` is:

```
-----display.py — A simple way to trace the intermediate steps of algorithms.-----
11 | class Displayable(object):
12 |     """Class that uses 'display'.
13 |     The amount of detail is controlled by max_display_level
14 |     """
15 |     max_display_level = 1 # can be overridden in subclasses or instances
16 |
17 |     def display(self, level, *args, **nargs):
18 |         """print the arguments if level is less than or equal to the
19 |         current max_display_level.
20 |         level is an integer.
21 |         the other arguments are whatever arguments print can take.
22 |         """
23 |         if level <= self.max_display_level:
24 |             print(*args, **nargs) ##if error you are using Python2 not
                Python3
```

(Note that `args` gets a tuple of the positional arguments, and `nargs` gets a dictionary of the keyword arguments). This will not work in Python 2, and will give an error.

Any class that wants to use `display` can be made a subclass of `Displayable`. To change the maximum display level to 3 for a class do:

```
Classname.max_display_level = 3
```

which will make calls to `display` in that class print when the value of `level` is less-than-or-equal to 3. The default display level is 1. It can also be changed for individual objects (the object value overrides the class value).

The value of `max_display_level` by convention is:

- 0 display nothing
- 1 display solutions (nothing that happens repeatedly)
- 2 also display the values as they change (little detail through a loop)
- 3 also display more details
- 4 and above even more detail

### 1.7.2 Argmax

Python has a built-in `max` function that takes a generator (or a list or set) and returns the maximum value. The `argmax` method returns the index of an element that has the maximum value. If there are multiple elements with the maximum value, one of the indexes to that value is returned at random. `argmaxe` assumes an enumeration; a generator of *(element, value)* pairs, as for example is generated by the built-in `enumerate(list)` for lists or `dict.items()` for dictionaries.

```

_____utilities.py — AIPython useful utilities_____
11 import random
12 import math
13
14 def argmaxall(gen):
15     """gen is a generator of (element,value) pairs, where value is a real.
16     argmaxall returns a list of all of the elements with maximal value.
17     """
18     maxv = -math.inf    # negative infinity
19     maxvals = []      # list of maximal elements
20     for (e,v) in gen:
21         if v>maxv:
22             maxvals,maxv = [e], v
23         elif v==maxv:
24             maxvals.append(e)
25     return maxvals
26
27 def argmaxe(gen):
28     """gen is a generator of (element,value) pairs, where value is a real.
29     argmaxe returns an element with maximal value.
30     If there are multiple elements with the max value, one is returned at
31         random.
32     """
33     return random.choice(argmaxall(gen))
34 def argmax(lst):

```

```

35     """returns maximum index in a list"""
36     return argmaxe(enumerate(lst))
37 # Try:
38 # argmax([1,6,3,77,3,55,23])
39
40 def argmaxd(dct):
41     """returns the arg max of a dictionary dct"""
42     return argmaxe(dct.items())
43 # Try:
44 # arxmaxd({2:5,5:9,7:7})

```

**Exercise 1.3** Change `argmaxall` to have an optional argument that specifies whether you want the “first”, “last” or a “random” index of the maximum value returned. If you want the first or the last, you don’t need to keep a list of the maximum elements. Enable the other methods to have this optional argument.

### 1.7.3 Probability

For many of the simulations, we want to make a variable True with some probability. `flip(p)` returns True with probability  $p$ , and otherwise returns False.

```

_____utilities.py — (continued)_____
45 def flip(prob):
46     """return true with probability prob"""
47     return random.random() < prob

```

The `select_from_dist` method takes in a *item : probability* dictionary, and returns one of the items in proportion to its probability. The probabilities should sum to 1 or more. If they sum to more than one, the excess is ignored.

```

_____utilities.py — (continued)_____
49 def select_from_dist(item_prob_dist):
50     """ returns a value from a distribution.
51     item_prob_dist is an item:probability dictionary, where the
52     probabilities sum to 1.
53     returns an item chosen in proportion to its probability
54     """
55     ranreal = random.random()
56     for (it,prob) in item_prob_dist.items():
57         if ranreal < prob:
58             return it
59         else:
60             ranreal -= prob
61     raise RuntimeError(f"{item_prob_dist} is not a probability
        distribution")

```

## 1.8 Testing Code

It is important to test code early and test it often. We include a simple form of **unit test**. The value of the current module is in `__name__` and if the module is run at the top-level, its value is `"__main__"`. See [https://docs.python.org/3/library/\\_\\_main\\_\\_.html](https://docs.python.org/3/library/__main__.html).

The following code tests `argmax` and `dict_union`, but only when if `utilities` is loaded in the top-level. If it is loaded in a module the test code is not run.

In your code, you should do more substantial testing than done here. In particular, you should also test boundary cases.

```

_____utilities.py — (continued)_____
63 def test():
64     """Test part of utilities"""
65     assert argmax([1,6,55,3,55,23]) in [2,4]
66     print("Passed unit test in utilities")
67     print("run test_aipython() to test (almost) everything")
68
69 if __name__ == "__main__":
70     test()

```

The following does a simple check of all of AIPython that has automatic checks. If you develop new algorithms or tests, add them here!

```

_____utilities.py — (continued)_____
72 def test_aipython():
73     # Agents: currently no tests
74     # Search:
75     print("***** testing Search *****")
76     import searchGeneric, searchBranchAndBound, searchExample, searchTest
77     searchGeneric.test(searchGeneric.AStarSearcher)
78     searchBranchAndBound.test(searchBranchAndBound.DF_branch_and_bound)
79     searchTest.run(searchExample.problem1,"Problem 1")
80     # CSP
81     print("\n***** testing CSP *****")
82     import cspExamples, cspDFS, cspSearch, cspConsistency, cspSLS
83     cspExamples.test_csp(cspDFS.dfs_solve1)
84     cspExamples.test_csp(cspSearch.solver_from_searcher)
85     cspExamples.test_csp(cspConsistency.ac_solver)
86     cspExamples.test_csp(cspConsistency.ac_search_solver)
87     cspExamples.test_csp(cspSLS.sls_solver)
88     cspExamples.test_csp(cspSLS.any_conflict_solver)
89     # Propositions
90     print("\n***** testing Propositional Logic *****")
91     import logicBottomUp, logicTopDown, logicExplain, logicNegation
92     logicBottomUp.test()
93     logicTopDown.test()
94     logicExplain.test()
95     logicNegation.test()
96     # Planning

```

```

97  print("\n***** testing Planning *****")
98  import stripsHeuristic
99  stripsHeuristic.test_forward_heuristic()
100 stripsHeuristic.test_regression_heuristic()
101 # Learning
102 print("\n***** testing Learning *****")
103 import learnProblem, learnNoInputs, learnDT, learnLinear
104 learnNoInputs.test_no_inputs(training_sizes=[4])
105 data = learnProblem.Data_from_file('data/carbool.csv', target_index=-1,
106     seed=123)
107 learnDT.testDT(data, print_tree=False)
108 learnLinear.test()
109 # Deep Learning: currently no tests
110 # Uncertainty
111 print("\n***** testing Uncertainty *****")
112 import probGraphicalModels, probRC, probVE, probStochSim
113 probGraphicalModels.InferenceMethod.testIM(probRC.ProbSearch)
114 probGraphicalModels.InferenceMethod.testIM(probRC.ProbRC)
115 probGraphicalModels.InferenceMethod.testIM(probVE.VE)
116 probGraphicalModels.InferenceMethod.testIM(probStochSim.RejectionSampling,
117     threshold=0.1)
118 probGraphicalModels.InferenceMethod.testIM(probStochSim.LikelihoodWeighting,
119     threshold=0.1)
120 probGraphicalModels.InferenceMethod.testIM(probStochSim.ParticleFiltering,
121     threshold=0.1)
122 probGraphicalModels.InferenceMethod.testIM(probStochSim.GibbsSampling,
123     threshold=0.1)
124 # Learning under uncertainty: currently no tests
125 # Causality: currently no tests
126 # Planning under uncertainty
127 print("\n***** testing Planning under Uncertainty *****")
128 import decnNetworks
129 decnNetworks.test(decnNetworks.fire_dn)
130 import mdpExamples
131 mdpExamples.test_MDP(mdpExamples.partyMDP)
132 # Reinforcement Learning:
133 print("\n***** testing Reinforcement Learning *****")
134 import rlQLearner
135 rlQLearner.test_RL(rlQLearner.Q_learner, alpha_fun=lambda k:10/(9+k))
136 import rlQExperienceReplay
137 rlQLearner.test_RL(rlQExperienceReplay.Q_ER_learner, alpha_fun=lambda
138     k:10/(9+k))
139 import rlStochasticPolicy
140 rlQLearner.test_RL(rlStochasticPolicy.StochasticPIAgent,
141     alpha_fun=lambda k:10/(9+k))
142 import rlModelLearner
143 rlQLearner.test_RL(rlModelLearner.Model_based_reinforcement_learner)
144 import rlFeatures
145 rlQLearner.test_RL(rlFeatures.SARSA_LFA_learner,
146     es_kwargs={'epsilon':1}, eps=4)

```

```
139 | # Multiagent systems: currently no tests
140 | # Individuals and Relations
141 | print("\\n***** testing Datalog and Logic Programming *****")
142 | import relnExamples
143 | relnExamples.test_ask_all()
144 | # Knowledge Graphs and Onologies
145 | print("\\n***** testing Knowledge Graphs and Onologies *****")
146 | import knowledgeGraph
147 | knowledgeGraph.test_kg()
148 | # Relational Learning: currently no tests
```



## Agent Architectures and Hierarchical Control

This implements the controllers described in Chapter 2 of Poole and Mackworth [2023].

These provide sequential implementations of the control. More sophisticated version may have them run concurrently (either as coroutines or in parallel).

In this version the higher-levels call the lower-levels. The higher-levels calling the lower-level works in simulated environments when there is a single agent, and where the lower-level are written to make sure they return (and don't go on forever), and the higher level doesn't take too long (as the lower-levels will wait until called again).

### 2.1 Representing Agents and Environments

In the initial implementation, both agents and the environment are treated as objects in the sense of object-oriented programs: they can have an internal state they maintain, and can evaluate methods that can provide answers. This is the same representation used for the reinforcement learning algorithms (Chapter 13).

An **environment** takes in actions of the agents, updates its internal state and returns the next percept, using the method `do`.

An **agent** takes the percept, updates its internal state, and outputs its next action. An agent implements the method `select_action` that takes percept and returns its next action.

The methods `do` and `select_action` are chained together to build a simulator. In order to start this, we need either an action or a percept. There are two variants used:

- An agent implements the `initial_action()` method which is used initially. This is the method used in the reinforcement learning chapter (page 307).
- The environment implements the `initial_percept()` method which gives the initial percept. This is the method used in this chapter.

In this implementation, the state of the agent and the state of the environment are represented using standard Python variables, which are updated as the state changes. The percept and the actions are represented as variable-value dictionaries. When agent has only a limited number of actions, the action can be a single value.

In the following code `raise NotImplementedError()` is a way to specify an abstract method that needs to be overridden in any implemented agent or environment.

```

agents.py — Agent and Controllers
11 from display import Displayable
12
13 class Agent(Displayable):
14
15     def initial_action(self, percept):
16         """return the initial action."""
17         return self.select_action(percept) # same as select_action
18
19     def select_action(self, percept):
20         """return the next action (and update internal state) given percept
21         percept is variable:value dictionary
22         """
23         raise NotImplementedError("go") # abstract method

```

The environment implements a `do(action)` method where `action` is a variable-value dictionary. This returns a percept, which is also a variable-value dictionary. The use of dictionaries allows for structured actions and percepts.

Note that `Environment` is a subclass of `Displayable` so that it can use the `display` method described in Section 1.7.1.

```

agents.py — (continued)
25 class Environment(Displayable):
26     def initial_percept(self):
27         """returns the initial percept for the agent"""
28         raise NotImplementedError("initial_percept") # abstract method
29
30     def do(self, action):
31         """does the action in the environment

```

```

32     returns the next percept """
33     raise NotImplementedError("Environment.do") # abstract method

```

The simulator lets the agent and the environment take turns in updating their states and returning the action and the percept.

The first implementation is a simple procedure to carry out  $n$  steps of the simulation and return the agent state and the environment state at the end.

```

agents.py — (continued)
35 class Simulate(Displayable):
36     """simulate the interaction between the agent and the environment
37     for n time steps.
38     Returns a pair of the agent state and the environment state.
39     """
40     def __init__(self, agent, environment):
41         self.agent = agent
42         self.env = environment
43         self.percept = self.env.initial_percept()
44         self.percept_history = [self.percept]
45         self.action_history = []
46
47     def go(self, n):
48         for i in range(n):
49             action = self.agent.select_action(self.percept)
50             self.display(2, f"i={i} action={action}")
51             self.percept = self.env.do(action)
52             self.display(2, f"    percept={self.percept}")

```

## 2.2 Paper buying agent and environment

To run the demo, in folder "aipython", load "agents.py", using e.g., `ipython -i agentBuying.py`, and copy and paste the commented-out commands at the bottom of that file.

This is an implementation of Example 2.1 of Poole and Mackworth [2023]. You might get different plots to Figures 2.2 and 2.3 as there is randomness in the environment.

### 2.2.1 The Environment

The environment state is given in terms of the time and the amount of paper in stock. It also remembers the in-stock history and the price history. The percept consists of the price and the amount of paper in stock. The action of the agent is the number to buy.

Here we assume that the prices are obtained from the prices list (which cycles) plus a random integer in range  $[0, \text{max\_price\_addon})$  plus a linear "in-

flation". The agent cannot access the price model; it just observes the prices and the amount in stock.

```

agentBuying.py — Paper-buying agent
11 import random
12 from agents import Agent, Environment, Simulate
13 from utilities import select_from_dist
14
15 class TP_env(Environment):
16     price_delta = [0, 0, 0, 21, 0, 20, 0, -64, 0, 0, 23, 0, 0, 0, -35,
17                   0, 76, 0, -41, 0, 0, 0, 21, 0, 5, 0, 5, 0, 0, 0, 5, 0, -15, 0, 5,
18                   0, 5, 0, -115, 0, 115, 0, 5, 0, -15, 0, 5, 0, 5, 0, 0, 0, 5, 0,
19                   -59, 0, 44, 0, 5, 0, 5, 0, 0, 0, 5, 0, -65, 50, 0, 5, 0, 5, 0, 0,
20                   0, 5, 0]
21     sd = 5 # noise standard deviation
22
23     def __init__(self):
24         """paper buying agent"""
25         self.time=0
26         self.stock=20
27         self.stock_history = [] # memory of the stock history
28         self.price_history = [] # memory of the price history
29
30     def initial_percept(self):
31         """return initial percept"""
32         self.stock_history.append(self.stock)
33         self.price = round(234+self.sd*random.gauss(0,1))
34         self.price_history.append(self.price)
35         return {'price': self.price,
36               'instock': self.stock}
37
38     def do(self, action):
39         """does action (buy) and returns percept consisting of price and
40           instock"""
41         used = select_from_dist({6:0.1, 5:0.1, 4:0.1, 3:0.3, 2:0.2, 1:0.2})
42         # used = select_from_dist({7:0.1, 6:0.2, 5:0.2, 4:0.3, 3:0.1,
43           2:0.1}) # uses more paper
44         bought = action['buy']
45         self.stock = self.stock+bought-used
46         self.stock_history.append(self.stock)
47         self.time += 1
48         self.price = round(self.price
49           + self.price_delta[self.time%len(self.price_delta)] #
50           repeating pattern
51           + self.sd*random.gauss(0,1)) # plus randomness
52         self.price_history.append(self.price)
53         return {'price': self.price,
54               'instock': self.stock}

```

### 2.2.2 The Agent

The agent does not have access to the price model but can only observe the current price and the amount in stock. It has to decide how much to buy.

The belief state of the agent is an estimate of the average price of the paper, and the total amount of money the agent has spent.

```

agentBuying.py — (continued)
53 class TP_agent(Agent):
54     def __init__(self):
55         self.spent = 0
56         percept = env.initial_percept()
57         self.ave = self.last_price = percept['price']
58         self.instock = percept['instock']
59         self.buy_history = []
60
61     def select_action(self, percept):
62         """return next action to carry out
63         """
64         self.last_price = percept['price']
65         self.ave = self.ave+(self.last_price-self.ave)*0.05
66         self.instock = percept['instock']
67         if self.last_price < 0.9*self.ave and self.instock < 60:
68             tobuy = 48
69         elif self.instock < 12:
70             tobuy = 12
71         else:
72             tobuy = 0
73         self.spent += tobuy*self.last_price
74         self.buy_history.append(tobuy)
75         return {'buy': tobuy}

```

Set up an environment and an agent. Uncomment the last lines to run the agent for 90 steps, and determine the average amount spent.

```

agentBuying.py — (continued)
77 env = TP_env()
78 ag = TP_agent()
79 sim = Simulate(ag,env)
80 #sim.go(90)
81 #ag.spent/env.time ## average spent per time period

```

### 2.2.3 Plotting

The following plots the price and number in stock history:

```

agentBuying.py — (continued)
83 import matplotlib.pyplot as plt
84
85 class Plot_history(object):

```

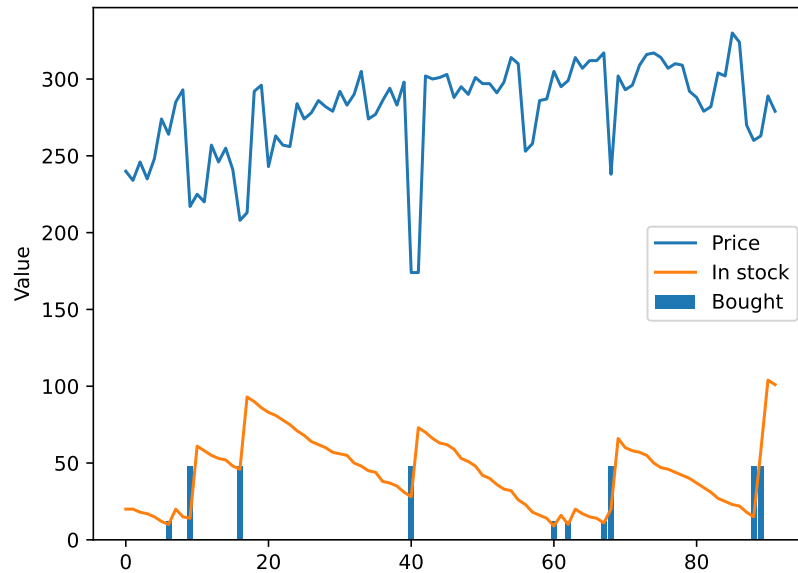

Figure 2.1: Percept and command traces for the paper-buying agent

```

86     """Set up the plot for history of price and number in stock"""
87     def __init__(self, ag, env):
88         self.ag = ag
89         self.env = env
90         plt.ion()
91         plt.xlabel("Time")
92         plt.ylabel("Value")
93
94
95     def plot_env_hist(self):
96         """plot history of price and instock"""
97         num = len(env.stock_history)
98         plt.plot(range(num), env.price_history, label="Price")
99         plt.plot(range(num), env.stock_history, label="In stock")
100        plt.legend()
101        #plt.draw()
102
103     def plot_agent_hist(self):
104         """plot history of buying"""
105         num = len(ag.buy_history)
106         plt.bar(range(1, num+1), ag.buy_history, label="Bought")
107         plt.legend()
108         #plt.draw()
109
110 # sim.go(100); print(f"agent spent ${ag.spent/100}")
111 # pl = Plot_history(ag, env); pl.plot_env_hist(); pl.plot_agent_hist()

```

Figure 2.1 shows the result of the plotting in the previous code.

**Exercise 2.1** Design a better controller for a paper-buying agent.

- Justify a performance measure that is a fair comparison. Note that minimizing the total amount of money spent may be unfair to agents who have built up a stockpile, and favors agents that end up with no paper.
- Give a controller that can work for many different price histories. An agent can use other local state variables, but does not have access to the environment model.
- Is it worthwhile trying to infer the amount of paper that the home uses? (Try your controller with the different paper consumption commented out in `TP_env.do`.)

## 2.3 Hierarchical Controller

To run the hierarchical controller, in folder "aipython", load "agentTop.py", using e.g., `ipython -i agentTop.py`, and copy and paste the commands near the bottom of that file.

In this implementation, each layer, including the top layer, implements the environment class, because each layer is seen as an environment from the layer above.

We arbitrarily divide the environment and the body, so that the environment just defines the walls, and the body includes everything to do with the agent. Note that the named locations are part of the (top-level of the) agent, not part of the environment, although they could have been.

### 2.3.1 Environment

The environment defines the walls.

```

agentEnv.py — Agent environment
11 import math
12 from display import Displayable
13 from agents import Environment
14
15 class Rob_env(Environment):
16     def __init__(self, walls = {}):
17         """walls is a set of line segments
18             where each line segment is of the form ((x0,y0),(x1,y1))
19         """
20         self.walls = walls

```

### 2.3.2 Body

The body defines everything about the agent body.

```

agentEnv.py — (continued)
22 import math
23 from agents import Environment
24 import matplotlib.pyplot as plt
25 import time
26
27 class Rob_body(Environment):
28     def __init__(self, env, init_pos=(0,0,90)):
29         """ env is the current environment
30         init_pos is a triple of (x-position, y-position, direction)
31         direction is in degrees; 0 is to right, 90 is straight-up, etc
32         """
33         self.env = env
34         self.rob_x, self.rob_y, self.rob_dir = init_pos
35         self.turning_angle = 18 # degrees that a left makes
36         self.whisker_length = 6 # length of the whisker
37         self.whisker_angle = 30 # angle of whisker relative to robot
38         self.crashed = False
39         # The following control how it is plotted
40         self.plotting = True # whether the trace is being plotted
41         self.sleep_time = 0.05 # time between actions (for real-time
42         plotting)
43         # The following are data structures maintained:
44         self.history = [(self.rob_x, self.rob_y)] # history of (x,y)
45         positions
46         self.wall_history = [] # history of hitting the wall
47
48     def percept(self):
49         return {'rob_x_pos':self.rob_x, 'rob_y_pos':self.rob_y,
50             'rob_dir':self.rob_dir, 'whisker':self.whisker(),
51             'crashed':self.crashed}
52     initial_percept = percept # use percept function for initial percept too
53
54     def do(self,action):
55         """ action is {'steer':direction}
56         direction is 'left', 'right' or 'straight'
57         """
58         if self.crashed:
59             return self.percept()
60         direction = action['steer']
61         compass_deriv =
62             {'left':1,'straight':0,'right':-1}[direction]*self.turning_angle
63         self.rob_dir = (self.rob_dir + compass_deriv +360)%360 # make in
64         range [0,360)
65         rob_x_new = self.rob_x + math.cos(self.rob_dir*math.pi/180)
66         rob_y_new = self.rob_y + math.sin(self.rob_dir*math.pi/180)
67         path = ((self.rob_x,self.rob_y),(rob_x_new,rob_y_new))

```

```

63     if any(line_segments_intersect(path,wall) for wall in
64         self.env.walls):
65         self.crashed = True
66         if self.plotting:
67             plt.plot([self.rob_x],[self.rob_y],"r*",markersize=20.0)
68             plt.draw()
69         self.rob_x, self.rob_y = rob_x_new, rob_y_new
70         self.history.append((self.rob_x, self.rob_y))
71         if self.plotting and not self.crashed:
72             plt.plot([self.rob_x],[self.rob_y],"go")
73             plt.draw()
74             plt.pause(self.sleep_time)
75         return self.percept()

```

The Boolean whisker method returns True when the whisker and the wall intersect.

agentEnv.py — (continued)

```

76     def whisker(self):
77         """returns true whenever the whisker sensor intersects with a wall
78         """
79         whisk_ang_world = (self.rob_dir-self.whisker_angle)*math.pi/180
80         # angle in radians in world coordinates
81         wx = self.rob_x + self.whisker_length * math.cos(whisk_ang_world)
82         wy = self.rob_y + self.whisker_length * math.sin(whisk_ang_world)
83         whisker_line = ((self.rob_x,self.rob_y),(wx,wy))
84         hit = any(line_segments_intersect(whisker_line,wall)
85                 for wall in self.env.walls)
86         if hit:
87             self.wall_history.append((self.rob_x, self.rob_y))
88             if self.plotting:
89                 plt.plot([self.rob_x],[self.rob_y],"ro")
90                 plt.draw()
91         return hit
92
93     def line_segments_intersect(linea,lineb):
94         """returns true if the line segments, linea and lineb intersect.
95         A line segment is represented as a pair of points.
96         A point is represented as a (x,y) pair.
97         """
98         ((x0a,y0a),(x1a,y1a)) = linea
99         ((x0b,y0b),(x1b,y1b)) = lineb
100        da, db = x1a-x0a, x1b-x0b
101        ea, eb = y1a-y0a, y1b-y0b
102        denom = db*ea-eb*da
103        if denom==0: # line segments are parallel
104            return False
105        cb = (da*(y0b-y0a)-ea*(x0b-x0a))/denom # position along line b
106        if cb<0 or cb>1:
107            return False
108        ca = (db*(y0b-y0a)-eb*(x0b-x0a))/denom # position along line a

```

```

109     return 0<=ca<=1
110
111 # Test cases:
112 # assert line_segments_intersect(((0,0),(1,1)),((1,0),(0,1)))
113 # assert not line_segments_intersect(((0,0),(1,1)),((1,0),(0.6,0.4)))
114 # assert line_segments_intersect(((0,0),(1,1)),((1,0),(0.4,0.6)))

```

### 2.3.3 Middle Layer

The middle layer acts like both a controller (for the environment layer) and an environment for the upper layer. It has to tell the environment how to steer. Thus it calls *env.do(·)*. It also is told the position to go to and the timeout. Thus it also has to implement *do(·)*.

```

agentMiddle.py — Middle Layer
11 from agents import Environment
12 import math
13
14 class Rob_middle_layer(Environment):
15     def __init__(self,env):
16         self.env=env
17         self.percept = env.initial_percept()
18         self.straight_angle = 11 # angle that is close enough to straight
19         self.close_threshold = 2 # distance that is close enough to arrived
20         self.close_threshold_squared = self.close_threshold**2 # just
21         compute it once
22
23     def initial_percept(self):
24         return {}
25
26     def do(self, action):
27         """action is {'go_to':target_pos,'timeout':timeout}
28         target_pos is (x,y) pair
29         timeout is the number of steps to try
30         returns {'arrived':True} when arrived is true
31         or {'arrived':False} if it reached the timeout
32         """
33         if 'timeout' in action:
34             remaining = action['timeout']
35         else:
36             remaining = -1 # will never reach 0
37         target_pos = action['go_to']
38         arrived = self.close_enough(target_pos)
39         while not arrived and remaining != 0:
40             self.percept = self.env.do({"steer":self.steer(target_pos)})
41             remaining -= 1
42             arrived = self.close_enough(target_pos)
43         return {'arrived':arrived}

```

The following method determines how to steer depending on whether the goal is to the right or the left of where the robot is facing.

```

agentMiddle.py — (continued)
44 def steer(self, target_pos):
45     if self.percept['whisker']:
46         self.display(3, 'whisker on', self.percept)
47         return "left"
48     else:
49         return self.head_towards(target_pos)
50
51 def head_towards(self, target_pos):
52     """ given a target position, return the action that heads
53         towards that position
54     """
55     gx, gy = target_pos
56     rx, ry = self.percept['rob_x_pos'], self.percept['rob_y_pos']
57     goal_dir = math.acos((gx-rx)/math.sqrt((gx-rx)*(gx-rx)
58         +(gy-ry)*(gy-ry)))*180/math.pi
59     if ry>gy:
60         goal_dir = -goal_dir
61     goal_from_rob = (goal_dir - self.percept['rob_dir']+540)%360-180
62     assert -180 < goal_from_rob <= 180
63     if goal_from_rob > self.straight_angle:
64         return "left"
65     elif goal_from_rob < -self.straight_angle:
66         return "right"
67     else:
68         return "straight"
69
70 def close_enough(self, target_pos):
71     gx, gy = target_pos
72     rx, ry = self.percept['rob_x_pos'], self.percept['rob_y_pos']
73     return (gx-rx)**2 + (gy-ry)**2 <= self.close_threshold_squared

```

### 2.3.4 Top Layer

The top layer treats the middle layer as its environment. Note that the top layer is an environment for us to tell it what to visit.

```

agentTop.py — Top Layer
11 from display import Displayable
12 from agentMiddle import Rob_middle_layer
13 from agents import Environment
14
15 class Rob_top_layer(Environment):
16     def __init__(self, middle, timeout=200, locations = {'mail':(-5,10),
17         'o103':(50,10), 'o109':(100,10), 'storage':(101,51)}
18         ):
19         """middle is the middle layer

```

```

19 |         timeout is the number of steps the middle layer goes before giving
20 |             up
21 |         locations is a loc:pos dictionary
22 |             where loc is a named location, and pos is an (x,y) position.
23 |         """
24 |         self.middle = middle
25 |         self.timeout = timeout # number of steps before the middle layer
26 |             should give up
27 |         self.locations = locations
28 |
29 |     def do(self,plan):
30 |         """carry out actions.
31 |         actions is of the form {'visit':list_of_locations}
32 |         It visits the locations in turn.
33 |         """
34 |         to_do = plan['visit']
35 |         for loc in to_do:
36 |             position = self.locations[loc]
37 |             arrived = self.middle.do({'go_to':position,
38 |                                     'timeout':self.timeout})
39 |             self.display(1,"Arrived at",loc,arrived)

```

### 2.3.5 Plotting

The following is used to plot the locations, the walls and (eventually) the movement of the robot. It can either plot the movement if the robot as it is going (with the default `env.plotting = True`), or not plot it as it is going (setting `env.plotting = False`; in this case the trace can be plotted using `pl.plot_run()`).

```

agentTop.py — (continued)
38 | import matplotlib.pyplot as plt
39 |
40 | class Plot_env(Displayable):
41 |     def __init__(self, body,top):
42 |         """sets up the plot
43 |         """
44 |         self.body = body
45 |         self.top = top
46 |         plt.ion()
47 |         plt.axes().set_aspect('equal')
48 |         self.redraw()
49 |
50 |     def redraw(self):
51 |         plt.clf()
52 |         for wall in body.env.walls:
53 |             ((x0,y0),(x1,y1)) = wall
54 |             plt.plot([x0,x1],[y0,y1],"-k",linewidth=3)
55 |         for loc in top.locations:
56 |             (x,y) = top.locations[loc]

```

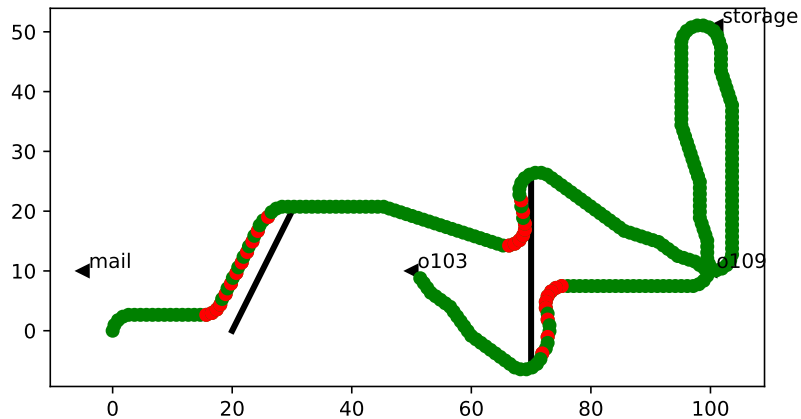

Figure 2.2: A trace of the trajectory of the agent. Red dots correspond to the whisker sensor being on; the green dot to the whisker sensor being off. The agent starts at position (0,0) facing up.

```

57     plt.plot([x],[y],"k<")
58     plt.text(x+1.0,y+0.5,loc) # print the label above and to the
    right
59     plt.plot([body.rob_x],[body.rob_y],"go")
60     plt.gca().figure.canvas.draw()
61     if self.body.history or self.body.wall_history:
62         self.plot_run()
63
64     def plot_run(self):
65         """plots the history after the agent has finished.
66         This is typically only used if body.plotting==False
67         """
68         if self.body.history:
69             xs,ys = zip(*self.body.history)
70             plt.plot(xs,ys,"go")
71         if self.body.wall_history:
72             wxs,wys = zip(*self.body.wall_history)
73             plt.plot(wxs,wys,"ro")

```

The following code plots the agent as it acts in the world. Figure 2.2 shows the result of the `top.do`

```

agentTop.py — (continued)
75 from agentEnv import Rob_body, Rob_env
76
77 env = Rob_env({((20,0),(30,20)), ((70,-5),(70,25))})
78 body = Rob_body(env)
79 middle = Rob_middle_layer(body)
80 top = Rob_top_layer(middle)
81
82 # try:

```

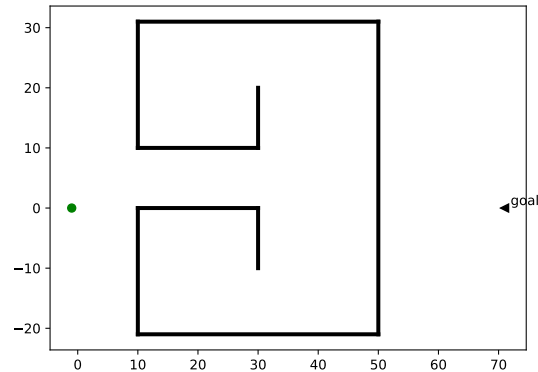

Figure 2.3: Robot trap

```

83 # pl=Plot_env(body, top)
84 # top.do({'visit':['o109', 'storage', 'o109', 'o103']})
85 # You can directly control the middle layer:
86 # middle.do({'go_to':(30,-10), 'timeout':200})
87 # Can you make it crash?

```

**Exercise 2.2** The following code implements a robot trap (Figure 2.3). Write a controller that can escape the “trap” and get to the goal. See Exercise 2.4 in the textbook for hints.

```

agentTop.py — (continued)
89 # Robot Trap for which the current controller cannot escape:
90 trap_env = Rob_env(((10,-21),(10,0)), ((10,10),(10,31)),
91                 ((30,-10),(30,0)),
92                 ((30,10),(30,20)), ((50,-21),(50,31)),
93                 ((10,-21),(50,-21)),
94                 ((10,0),(30,0)), ((10,10),(30,10)), ((10,31),(50,31)))
95 trap_body = Rob_body(trap_env, init_pos=(-1,0,90))
96 trap_middle = Rob_middle_layer(trap_body)
97 trap_top = Rob_top_layer(trap_middle, locations={'goal':(71,0)})
98
99 # Robot trap exercise:
100 # pl=Plot_env(trap_body, trap_top)
101 # trap_top.do({'visit':['goal']})

```

### Plotting for Moving Targets

Exercise 2.5 refers to targets that can move. The following implements targets that can be moved by the user (using the mouse).

```

agentFollowTarget.py — Plotting for moving targets
11 import matplotlib.pyplot as plt
12 from agentTop import Plot_env, body, top

```

```

13
14 class Plot_follow(Plot_env):
15     def __init__(self, body, top, epsilon=2.5):
16         """plot the agent in the environment.
17         epsilon is the threshold how close someone needs to click to
18         select a location.
19         """
20         Plot_env.__init__(self, body, top)
21         self.epsilon = epsilon
22         self.canvas = plt.gca().figure.canvas
23         self.canvas.mpl_connect('button_press_event', self.on_press)
24         self.canvas.mpl_connect('button_release_event', self.on_release)
25         self.canvas.mpl_connect('motion_notify_event', self.on_move)
26         self.pressloc = None
27         self.pressevent = None
28         for loc in self.top.locations:
29             self.display(2,f" loc {loc} at {self.top.locations[loc]}")
30
31     def on_press(self, event):
32         self.display(2,'v',end="")
33         self.display(2,f"Press at ({event.xdata},{event.ydata}")
34         for loc in self.top.locations:
35             lx,ly = self.top.locations[loc]
36             if abs(event.xdata- lx) <= self.epsilon and abs(event.ydata-
37             ly) <= self.epsilon :
38                 self.pressloc = loc
39                 self.pressevent = event
40                 self.display(2,"moving",loc)
41
42     def on_release(self, event):
43         self.display(2,'^',end="")
44         if self.pressloc is not None: #and event.inaxes ==
45             self.pressevent.inaxes:
46                 self.top.locations[self.pressloc] = (event.xdata, event.ydata)
47                 self.display(1,f"Placing {self.pressloc} at {(event.xdata,
48                 event.ydata}")
49                 self.pressloc = None
50                 self.pressevent = None
51
52     def on_move(self, event):
53         if self.pressloc is not None: # and event.inaxes ==
54             self.pressevent.inaxes:
55                 self.display(2,'-',end="")
56                 self.top.locations[self.pressloc] = (event.xdata, event.ydata)
57                 self.redraw()
58         else:
59             self.display(2,'.',end="")
60
61 # try:
62 # pl=Plot_follow(body,top)

```

```
58 | # top.do({'visit':['o109','storage','o109','o103']})
```

**Exercise 2.3** Change the code to also allow walls to move.

## Searching for Solutions

### 3.1 Representing Search Problems

A search problem consists of:

- a start node
- a *neighbors* function that given a node, returns an enumeration of the arcs from the node
- a specification of a goal in terms of a Boolean function that takes a node and returns true if the node is a goal
- a (optional) heuristic function that, given a node, returns a non-negative real number. The heuristic function defaults to zero.

As far as the searcher is concerned a node can be anything. If multiple-path pruning is used, a node must be hashable. In the simple examples, it is a string, but in more complicated examples (in later chapters) it can be a tuple, a frozen set, or a Python object.

In the following code, “raise NotImplementedError()” is a way to specify that this is an abstract method that needs to be overridden to define an actual search problem.

```
searchProblem.py — representations of search problems
11 from display import Displayable
12 import matplotlib.pyplot as plt
13 import random
14
15 class Search_problem(Displayable):
16     """A search problem consists of:
```

```

17     * a start node
18     * a neighbors function that gives the neighbors of a node
19     * a specification of a goal
20     * a (optional) heuristic function.
21     The methods must be overridden to define a search problem."""
22
23     def start_node(self):
24         """returns start node"""
25         raise NotImplementedError("start_node") # abstract method
26
27     def is_goal(self,node):
28         """is True if node is a goal"""
29         raise NotImplementedError("is_goal") # abstract method
30
31     def neighbors(self,node):
32         """returns a list (or enumeration) of the arcs for the neighbors of
33         node"""
34         raise NotImplementedError("neighbors") # abstract method
35
36     def heuristic(self,n):
37         """Gives the heuristic value of node n.
38         Returns 0 if not overridden."""
39         return 0

```

The neighbors is a list of arcs. A (directed) arc consists of a from\_node node and a to\_node node. The arc is the pair (from\_node, to\_node), but can also contain a non-negative cost (which defaults to 1) and can be labeled with an action.

```

-----searchProblem.py --- (continued) -----
40 class Arc(object):
41     """An arc has a from_node and a to_node node and a (non-negative)
42     cost"""
43     def __init__(self, from_node, to_node, cost=1, action=None):
44         self.from_node = from_node
45         self.to_node = to_node
46         self.action = action
47         self.cost = cost
48         assert cost >= 0, (f"Cost cannot be negative: {self}, cost={cost}")
49
50     def __repr__(self):
51         """string representation of an arc"""
52         if self.action:
53             return f"{self.from_node} --{self.action}--> {self.to_node}"
54         else:
55             return f"{self.from_node} --> {self.to_node}"

```

### 3.1.1 Explicit Representation of Search Graph

The first representation of a search problem is from an explicit graph (as opposed to one that is generated as needed).

An **explicit graph** consists of

- a list or set of nodes
- a list or set of arcs
- a start node
- a list or set of goal nodes
- (optionally) a dictionary that maps a node to a heuristic value for that node

To define a search problem, we need to define the start node, the goal predicate, the neighbors function and the heuristic function.

```

56 searchProblem.py — (continued)
57 class Search_problem_from_explicit_graph(Search_problem):
58     """A search problem from an explicit graph.
59     """
60     def __init__(self, title, nodes, arcs, start=None, goals=set(), hmap={},
61                 positions=None, show_costs = True):
62         """ A search problem consists of:
63         * list or set of nodes
64         * list or set of arcs
65         * start node
66         * list or set of goal nodes
67         * hmap: dictionary that maps each node into its heuristic value.
68         * positions: dictionary that maps each node into its (x,y) position
69         * show_costs is used for show()
70         """
71         self.title = title
72         self.neighs = {}
73         self.nodes = nodes
74         for node in nodes:
75             self.neighs[node]=[]
76         self.arcs = arcs
77         for arc in arcs:
78             self.neighs[arc.from_node].append(arc)
79         self.start = start
80         self.goals = goals
81         self.hmap = hmap
82         if positions is None:
83             self.positions = {node:(random.random(),random.random()) for
84                               node in nodes}
84         else:

```

```

85         self.positions = positions
86         self.show_costs = show_costs
87
88
89     def start_node(self):
90         """returns start node"""
91         return self.start
92
93     def is_goal(self,node):
94         """is True if node is a goal"""
95         return node in self.goals
96
97     def neighbors(self,node):
98         """returns the neighbors of node (a list of arcs)"""
99         return self.neighs[node]
100
101     def heuristic(self,node):
102         """Gives the heuristic value of node n.
103         Returns 0 if not overridden in the hmap."""
104         if node in self.hmap:
105             return self.hmap[node]
106         else:
107             return 0
108
109     def __repr__(self):
110         """returns a string representation of the search problem"""
111         res=""
112         for arc in self.arcs:
113             res += f"{arc}. "
114         return res

```

### Graphical Display of a Search Graph

```

searchProblem.py — (continued)
116     def show(self, fontsize=10, node_color='orange', show_costs = None):
117         """Show the graph as a figure
118         """
119         self.fontsize = fontsize
120         if show_costs is not None: # override default definition
121             self.show_costs = show_costs
122         plt.ion() # interactive
123         ax = plt.figure().gca()
124         ax.set_axis_off()
125         plt.title(self.title, fontsize=fontsize)
126         self.show_graph(ax, node_color)
127
128     def show_graph(self, ax, node_color='orange'):
129         bbox =
            dict(boxstyle="round4,pad=1.0,rounding_size=0.5",facecolor=node_color)

```

```

130     for arc in self.arcs:
131         self.show_arc(ax, arc)
132     for node in self.nodes:
133         self.show_node(ax, node, node_color = node_color)
134
135     def show_node(self, ax, node, node_color):
136         x,y = self.positions[node]
137         ax.text(x,y,node,bbox=dict(boxstyle="round4,pad=1.0,rounding_size=0.5",
138                                   facecolor=node_color,
139                                   ha='center',va='center',
140                                   fontsize=self.fontsize)
141
142     def show_arc(self, ax, arc, arc_color='black', node_color='white'):
143         from_pos = self.positions[arc.from_node]
144         to_pos = self.positions[arc.to_node]
145         ax.annotate(arc.to_node, from_pos, xytext=to_pos,
146                    # arrowprops=dict(facecolor='black',
147                                      shrink=0.1, width=2),
148                    arrowprops={'arrowstyle':'<|-', 'linewidth':
149                                2, 'color':arc_color},
150                    bbox=dict(boxstyle="round4,pad=1.0,rounding_size=0.5",
151                              facecolor=node_color),
152                    ha='center',va='center',
153                    fontsize=self.fontsize)
154
155         # Add costs to middle of arcs:
156         if self.show_costs:
157             ax.text((from_pos[0]+to_pos[0])/2, (from_pos[1]+to_pos[1])/2,
158                    arc.cost, bbox=dict(pad=1,fc='w',ec='w'),
159                    ha='center',va='center',fontsize=self.fontsize)

```

### 3.1.2 Paths

A searcher will return a path from the start node to a goal node. A Python list is not a suitable representation for a path, as many search algorithms consider multiple paths at once, and these paths should share initial parts of the path. If we wanted to do this with Python lists, we would need to keep copying the list, which can be expensive if the list is long. An alternative representation is used here in terms of a recursive data structure that can share subparts.

A path is either:

- a node (representing a path of length 0) or
- a path, initial and an arc, where the `from_node` of the arc is the node at the end of initial.

These cases are distinguished in the following code by having `arc=None` if the path has length 0, in which case `initial` is the node of the path. Note that we only use the most basic form of Python's `yield` for enumerations (Section 1.5.4).

searchProblem.py — (continued)

```

157 class Path(object):
158     """A path is either a node or a path followed by an arc"""
159
160     def __init__(self, initial, arc=None):
161         """initial is either a node (in which case arc is None) or
162         a path (in which case arc is an object of type Arc)"""
163         self.initial = initial
164         self.arc=arc
165         if arc is None:
166             self.cost=0
167         else:
168             self.cost = initial.cost+arc.cost
169
170     def end(self):
171         """returns the node at the end of the path"""
172         if self.arc is None:
173             return self.initial
174         else:
175             return self.arc.to_node
176
177     def nodes(self):
178         """enumerates the nodes for the path.
179         This enumerates the nodes in the path from the last elements
180         backwards.
181         """
182         current = self
183         while current.arc is not None:
184             yield current.arc.to_node
185             current = current.initial
186         yield current.initial
187
188     def initial_nodes(self):
189         """enumerates the nodes for the path before the end node.
190         This calls nodes() for the initial part of the path.
191         """
192         if self.arc is not None:
193             yield from self.initial.nodes()
194
195     def __repr__(self):
196         """returns a string representation of a path"""
197         if self.arc is None:
198             return str(self.initial)
199         elif self.arc.action:
200             return f"{self.initial}\n --{self.arc.action}-->
201                 {self.arc.to_node}"
202         else:
203             return f"{self.initial} --> {self.arc.to_node}"

```

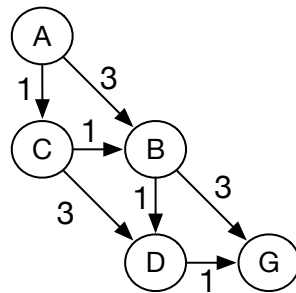

Figure 3.1: problem1

### 3.1.3 Example Search Problems

The first search problem is one with 5 nodes where the least-cost path is one with many arcs. See Figure 3.1. Note that this example is used for the unit tests, so the test (in `searchGeneric`) will need to be changed if this is changed.

```

searchExample.py — Search Examples
11 from searchProblem import Arc, Search_problem_from_explicit_graph,
    Search_problem
12
13 problem1 = Search_problem_from_explicit_graph('Problem 1',
14     {'A', 'B', 'C', 'D', 'G'},
15     [Arc('A', 'B', 3), Arc('A', 'C', 1), Arc('B', 'D', 1), Arc('B', 'G', 3),
16         Arc('C', 'B', 1), Arc('C', 'D', 3), Arc('D', 'G', 1)],
17     start = 'A',
18     goals = {'G'},
19     positions={'A': (0, 1), 'B': (0.5, 0.5), 'C': (0, 0.5), 'D': (0.5, 0),
        'G': (1, 0)})

```

The second search problem is one with 8 nodes where many paths do not lead to the goal. See Figure 3.2.

```

searchExample.py — (continued)
21 problem2 = Search_problem_from_explicit_graph('Problem 2',
22     {'A', 'B', 'C', 'D', 'E', 'G', 'H', 'J'},
23     [Arc('A', 'B', 1), Arc('B', 'C', 3), Arc('B', 'D', 1), Arc('D', 'E', 3),
24         Arc('D', 'G', 1), Arc('A', 'H', 3), Arc('H', 'J', 1)],
25     start = 'A',
26     goals = {'G'},
27     positions={'A': (0, 1), 'B': (0, 3/4), 'C': (0, 0), 'D': (1/4, 3/4), 'E':
        (1/4, 0),
28         'G': (2/4, 3/4), 'H': (3/4, 1), 'J': (3/4, 3/4)})

```

The third search problem is a disconnected graph (contains no arcs), where the start node is a goal node. This is a boundary case to make sure that weird cases work.

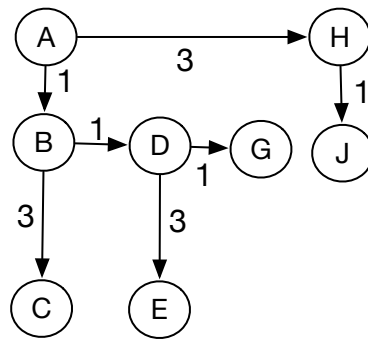

Figure 3.2: problem2

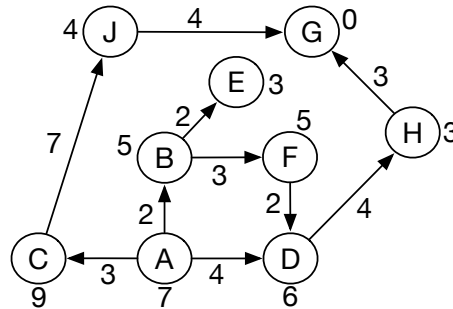

Figure 3.3: simp\_delivery\_graph with arc costs and h values of nodes

```

searchExample.py — (continued)
30 problem3 = Search_problem_from_explicit_graph('Problem 3',
31         {'a','b','c','d','e','g','h','j'},
32         [],
33         start = 'g',
34         goals = {'k','g'})

```

The `simp_delivery_graph` is the graph shown Figure 3.3. This is Figure 3.3 with the heuristics of Figure 3.1 as shown in Figure 3.13 of Poole and Mackworth [2023],

```

searchExample.py — (continued)
36 simp_delivery_graph = Search_problem_from_explicit_graph("Acyclic Delivery
37     Graph",
38     {'A', 'B', 'C', 'D', 'E', 'F', 'G', 'H', 'J'},
39     [
40         Arc('A', 'B', 2),
41         Arc('A', 'C', 3),

```

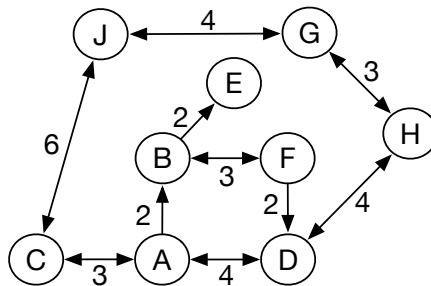

Figure 3.4: cyclic\_simp\_delivery\_graph with arc costs

```

42     Arc('B', 'F', 3),
43     Arc('C', 'J', 7),
44     Arc('D', 'H', 4),
45     Arc('F', 'D', 2),
46     Arc('H', 'G', 3),
47     Arc('J', 'G', 4)],
48     start = 'A',
49     goals = {'G'},
50     hmap = {
51         'A': 7,
52         'B': 5,
53         'C': 9,
54         'D': 6,
55         'E': 3,
56         'F': 5,
57         'G': 0,
58         'H': 3,
59         'J': 4,
60     },
61     positions = {
62         'A': (0.4,0.1),
63         'B': (0.4,0.4),
64         'C': (0.1,0.1),
65         'D': (0.7,0.1),
66         'E': (0.6,0.7),
67         'F': (0.7,0.4),
68         'G': (0.7,0.9),
69         'H': (0.9,0.6),
70         'J': (0.3,0.9)
71     }
72 )

```

cyclic\_simp\_delivery\_graph is the graph shown Figure 3.4. This is the graph of Figure 3.10 of [Poole and Mackworth, 2023]. The heuristic values are the same as in simp\_delivery\_graph.

```

searchExample.py -- (continued)
73 cyclic_simp_delivery_graph = Search_problem_from_explicit_graph("Cyclic
    Delivery Graph",
74     {'A', 'B', 'C', 'D', 'E', 'F', 'G', 'H', 'J'},
75     [
76         Arc('A', 'B', 2),
77         Arc('A', 'C', 3),
78         Arc('A', 'D', 4),
79         Arc('B', 'E', 2),
80         Arc('B', 'F', 3),
81         Arc('C', 'A', 3),
82         Arc('C', 'J', 6),
83         Arc('D', 'A', 4),
84         Arc('D', 'H', 4),
85         Arc('F', 'B', 3),
86         Arc('F', 'D', 2),
87         Arc('G', 'H', 3),
88         Arc('G', 'J', 4),
89         Arc('H', 'D', 4),
90         Arc('H', 'G', 3),
91         Arc('J', 'C', 6),
92         Arc('J', 'G', 4)],
93     start = 'A',
94     goals = {'G'},
95     hmap = {
96         'A': 7,
97         'B': 5,
98         'C': 9,
99         'D': 6,
100        'E': 3,
101        'F': 5,
102        'G': 0,
103        'H': 3,
104        'J': 4,
105    },
106    positions = {
107        'A': (0.4,0.1),
108        'B': (0.4,0.4),
109        'C': (0.1,0.1),
110        'D': (0.7,0.1),
111        'E': (0.6,0.7),
112        'F': (0.7,0.4),
113        'G': (0.7,0.9),
114        'H': (0.9,0.6),
115        'J': (0.3,0.9)
    })

```

The next problem is the tree graph shown in Figure 3.6, and is Figure 3.15 in Poole and Mackworth [2023].

```

searchExample.py -- (continued)
117 tree_graph = Search_problem_from_explicit_graph("Tree Graph",

```

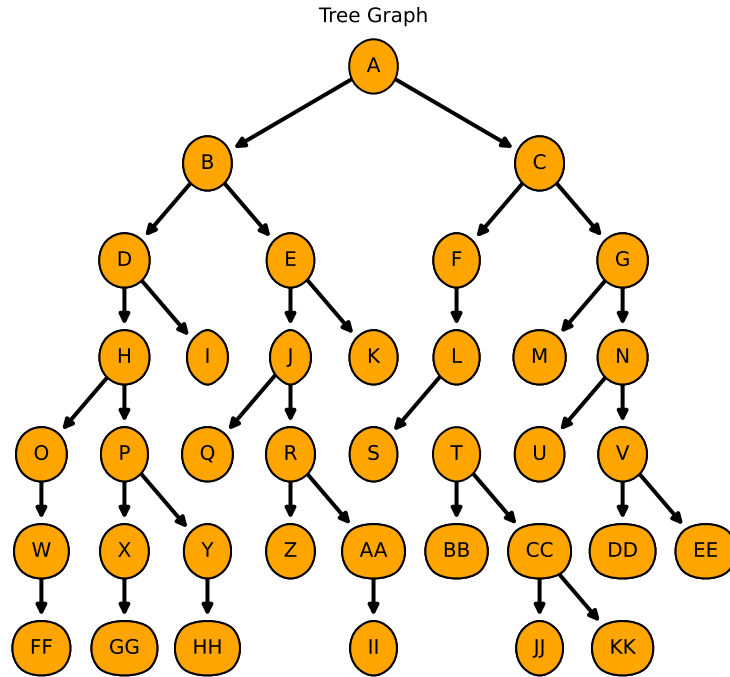

Figure 3.5: tree\_graph.show(show\_costs = False)

```

118 | {'A', 'B', 'C', 'D', 'E', 'F', 'G', 'H', 'I', 'J', 'K', 'L', 'M', 'N',
119 |     'O',
120 |     'P', 'Q', 'R', 'S', 'T', 'U', 'V', 'W', 'X', 'Y', 'Z', 'AA', 'BB',
121 |     'CC',
122 |     'DD', 'EE', 'FF', 'GG', 'HH', 'II', 'JJ', 'KK'},
123 | [ Arc('A', 'B', 1),
124 |   Arc('A', 'C', 1),
125 |   Arc('B', 'D', 1),
126 |   Arc('B', 'E', 1),
127 |   Arc('C', 'F', 1),
128 |   Arc('C', 'G', 1),
129 |   Arc('D', 'H', 1),
130 |   Arc('D', 'I', 1),
131 |   Arc('E', 'J', 1),
132 |   Arc('E', 'K', 1),
133 |   Arc('F', 'L', 1),
134 |   Arc('G', 'M', 1),
135 |   Arc('G', 'N', 1),

```

```

134     Arc('H', 'O', 1),
135     Arc('H', 'P', 1),
136     Arc('J', 'Q', 1),
137     Arc('J', 'R', 1),
138     Arc('L', 'S', 1),
139     Arc('L', 'T', 1),
140     Arc('N', 'U', 1),
141     Arc('N', 'V', 1),
142     Arc('O', 'W', 1),
143     Arc('P', 'X', 1),
144     Arc('P', 'Y', 1),
145     Arc('R', 'Z', 1),
146     Arc('R', 'AA', 1),
147     Arc('T', 'BB', 1),
148     Arc('T', 'CC', 1),
149     Arc('V', 'DD', 1),
150     Arc('V', 'EE', 1),
151     Arc('W', 'FF', 1),
152     Arc('X', 'GG', 1),
153     Arc('Y', 'HH', 1),
154     Arc('AA', 'II', 1),
155     Arc('CC', 'JJ', 1),
156     Arc('CC', 'KK', 1)
157 ],
158 start = 'A',
159 goals = {'K', 'M', 'T', 'X', 'Z', 'HH'},
160 positions = {
161     'A': (0.5,0.95),
162     'B': (0.3,0.8),
163     'C': (0.7,0.8),
164     'D': (0.2,0.65),
165     'E': (0.4,0.65),
166     'F': (0.6,0.65),
167     'G': (0.8,0.65),
168     'H': (0.2,0.5),
169     'I': (0.3,0.5),
170     'J': (0.4,0.5),
171     'K': (0.5,0.5),
172     'L': (0.6,0.5),
173     'M': (0.7,0.5),
174     'N': (0.8,0.5),
175     'O': (0.1,0.35),
176     'P': (0.2,0.35),
177     'Q': (0.3,0.35),
178     'R': (0.4,0.35),
179     'S': (0.5,0.35),
180     'T': (0.6,0.35),
181     'U': (0.7,0.35),
182     'V': (0.8,0.35),
183     'W': (0.1,0.2),

```

```

184         'X': (0.2,0.2),
185         'Y': (0.3,0.2),
186         'Z': (0.4,0.2),
187         'AA': (0.5,0.2),
188         'BB': (0.6,0.2),
189         'CC': (0.7,0.2),
190         'DD': (0.8,0.2),
191         'EE': (0.9,0.2),
192         'FF': (0.1,0.05),
193         'GG': (0.2,0.05),
194         'HH': (0.3,0.05),
195         'II': (0.5,0.05),
196         'JJ': (0.7,0.05),
197         'KK': (0.8,0.05)
198     },
199     show_costs = False
200 )
201
202 # tree_graph.show(show_costs = False)

```

## 3.2 Generic Searcher and Variants

To run the search demos, in folder “aipython”, load “searchGeneric.py”, using e.g., `ipython -i searchGeneric.py`, and copy and paste the example queries at the bottom of that file.

### 3.2.1 Searcher

A *Searcher* for a problem can be asked repeatedly for the next path. To solve a problem, you can construct a *Searcher* object for the problem and then repeatedly ask for the next path using *search*. If there are no more paths, *None* is returned.

```

_____ searchGeneric.py — Generic Searcher, including depth-first and A* _____
11 from display import Displayable
12
13 class Searcher(Displayable):
14     """returns a searcher for a problem.
15     Paths can be found by repeatedly calling search().
16     This does depth-first search unless overridden
17     """
18     def __init__(self, problem):
19         """creates a searcher from a problem
20         """
21         self.problem = problem
22         self.initialize_frontier()
23         self.num_expanded = 0

```

```

24     self.add_to_frontier(Path(problem.start_node()))
25     super().__init__()
26
27     def initialize_frontier(self):
28         self.frontier = []
29
30     def empty_frontier(self):
31         return self.frontier == []
32
33     def add_to_frontier(self,path):
34         self.frontier.append(path)
35
36     def search(self):
37         """returns (next) path from the problem's start node
38         to a goal node.
39         Returns None if no path exists.
40         """
41         while not self.empty_frontier():
42             self.path = self.frontier.pop()
43             self.num_expanded += 1
44             if self.problem.is_goal(self.path.end()): # solution found
45                 self.solution = self.path # store the solution found
46                 self.display(1, f"Solution: {self.path} (cost:
47                     {self.path.cost})\n",
48                     self.num_expanded, "paths have been expanded and",
49                     len(self.frontier), "paths remain in the
50                     frontier")
51                 return self.path
52             else:
53                 self.display(4, f"Expanding: {self.path} (cost:
54                     {self.path.cost})")
55                 neighs = self.problem.neighbors(self.path.end())
56                 self.display(2, f"Expanding: {self.path} with neighbors
57                     {neighs}")
58                 for arc in reversed(list(neighs)):
59                     self.add_to_frontier(Path(self.path,arc))
60                 self.display(3, f"New frontier: {[p.end() for p in
61                     self.frontier]}")
62
63         self.display(0, "No (more) solutions. Total of",
64                     self.num_expanded, "paths expanded.")

```

Note that this reverses the neighbors so that it implements depth-first search in an intuitive manner (expanding the first neighbor first). The call to *list* is for the case when the neighbors are generated (and not already in a list). Reversing the neighbors might not be required for other methods. The calls to *reversed* and *list* can be removed, and the algorithm still implements depth-first search.

To use depth-first search to find multiple paths for `problem1` and `simp_delivery_graph`, copy and paste the following into Python's read-evaluate-print loop; keep finding next solutions until there are no more:

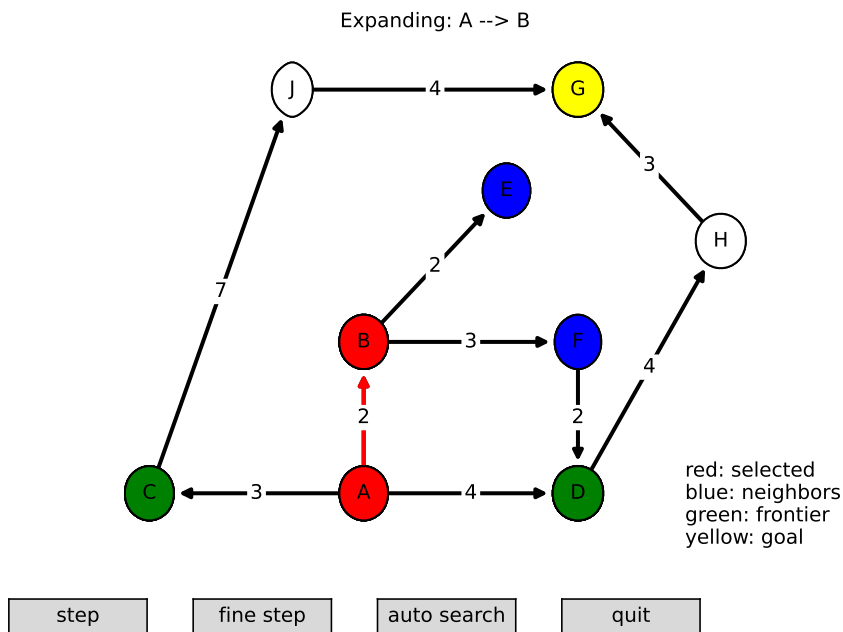

Figure 3.6: SearcherGUI(Searcher, simp\_delivery\_graph).go()

```

searchGeneric.py — (continued)
61 # Depth-first search for problem1; do the following:
62 # searcher1 = Searcher(searchExample.problem1)
63 # searcher1.search() # find first solution
64 # searcher1.search() # find next solution (repeat until no solutions)
65 # searcher_sdg = Searcher(searchExample.simp_delivery_graph)
66 # searcher_sdg.search() # find first or next solution

```

**Exercise 3.1** Implement breadth-first search. Only *add\_to\_frontier* and/or *pop* need to be modified to implement a first-in first-out queue.

### 3.2.2 GUI for Tracing Search

This GUI implements most of the functionality of the AISpace.org search app.

Figure 3.6 shows the GUI to step through various algorithms. Here the path  $A \rightarrow B$  is being expanded, and the neighbors are  $E$  and  $F$ . The other nodes at the end of paths of the frontier are  $C$  and  $D$ . Thus the frontier contains paths to  $C$  and  $D$ , used to also contain  $A \rightarrow B$ , and now will contain  $A \rightarrow B \rightarrow E$  and  $A \rightarrow B \rightarrow F$ .

SearcherGUI takes a search class and a problem, and lets one explore the search space after calling `go()`. A GUI can only be used for one search; at the end of the search the loop ends and the buttons no longer work.

This is implemented by redefining `display`. The search algorithms don't need to be modified. If you modify them (or create your own), you just have to be careful to use the appropriate number for the display. The first argument to `display` has the following meanings:

1. a solution has been found
2. what is shown for a "step" on a GUI; here it is assumed to be the path, the neighbors of the end of the path, and the other nodes at the end of paths on the frontier
3. (shown with "fine step" but not with "step") the frontier and the path selected
4. (shown with "fine step" but not with "step") the frontier.

It is also useful to look at the Python console, as the display information is printed there.

```

searchGUI.py — GUI for search
11 import matplotlib.pyplot as plt
12 from matplotlib.widgets import Button
13 import time
14
15 class SearcherGUI(object):
16     def __init__(self, SearchClass, problem, fontsize=10,
17                 colors = {'selected':'red', 'neighbors':'blue',
18                           'frontier':'green', 'goal':'yellow'}):
19         self.problem = problem
20         self.searcher = SearchClass(problem)
21         self.problem.fontsize = fontsize
22         self.colors = colors
23         #self.go()
24
25     def go(self):
26         fig, self.ax = plt.subplots()
27         plt.ion() # interactive
28         self.ax.set_axis_off()
29         plt.subplots_adjust(bottom=0.15)
30         step_but = Button(plt.axes([0.05,0.02,0.15,0.05]), "step")
31         step_but.on_clicked(self.step)
32         fine_but = Button(plt.axes([0.25,0.02,0.15,0.05]), "fine step")
33         fine_but.on_clicked(self.finestep)
34         auto_but = Button(plt.axes([0.45,0.02,0.15,0.05]), "auto search")
35         auto_but.on_clicked(self.auto)
36         quit_but = Button(plt.axes([0.65,0.02,0.15,0.05]), "quit")
37         quit_but.on_clicked(self.quit)
38         self.ax.text(0.85,0, '\n'.join(self.colors[a]+": "+a for a in
39                                     self.colors))
40         self.problem.show_graph(self.ax, node_color='white')

```

```

39     self.problem.show_node(self.ax, self.problem.start,
40                             self.colors['frontier'])
41     for node in self.problem.nodes:
42         if self.problem.is_goal(node):
43             self.problem.show_node(self.ax, node, self.colors['goal'])
44     plt.show()
45     self.click = 7 # bigger than any display!
46     #while self.click == 0:
47         # plt.pause(0.1)
48     self.searcher.display = self.display
49     try:
50         while self.searcher.frontier:
51             path = self.searcher.search()
52     except ExitToPython:
53         print("Exited")
54     else:
55         print("No more solutions")
56
57 def display(self, level, *args, **nargs):
58     if level <= self.click: #step
59         print(*args, **nargs)
60         self.ax.set_title(f"Expanding:
61                             {self.searcher.path}", fontsize=self.problem.fontsize)
62         if level == 1:
63             self.show_frontier(self.colors['frontier'])
64             self.show_path(self.colors['selected'])
65             self.ax.set_title(f"Solution Found:
66                             {self.searcher.path}", fontsize=self.problem.fontsize)
67         elif level == 2: # what should be shown if a node is in all
68             three?
69             self.show_frontier(self.colors['frontier'])
70             self.show_path(self.colors['selected'])
71             self.show_neighbors(self.colors['neighbors'])
72         elif level == 3:
73             self.show_frontier(self.colors['frontier'])
74             self.show_path(self.colors['selected'])
75         elif level == 4:
76             self.show_frontier(self.colors['frontier'])
77
78     # wait for a button click
79     self.click = 0
80     plt.draw()
81     while self.click == 0:
82         plt.pause(0.1)
83     # undo coloring:
84     self.ax.set_title("")
85     self.show_frontier('white')
86     self.show_neighbors('white')
87     path_show = self.searcher.path

```

```

85     while path_show.arc:
86         self.problem.show_arc(self.ax, path_show.arc, 'black')
87         self.problem.show_node(self.ax, path_show.end(), 'white')
88         path_show = path_show.initial
89         self.problem.show_node(self.ax, path_show.end(), 'white')
90     if self.problem.is_goal(self.searcher.path.end()):
91         self.problem.show_node(self.ax, self.searcher.path.end(),
92                                 self.colors['goal'])
93     plt.draw()
94
95     def show_frontier(self, color):
96         for path in self.searcher.frontier:
97             self.problem.show_node(self.ax, path.end(), color)
98
99     def show_path(self, color):
100        """color selected path"""
101        path_show = self.searcher.path
102        while path_show.arc:
103            self.problem.show_arc(self.ax, path_show.arc, color)
104            self.problem.show_node(self.ax, path_show.end(), color)
105            path_show = path_show.initial
106            self.problem.show_node(self.ax, path_show.end(), color)
107
108    def show_neighbors(self, color):
109        for neigh in self.problem.neighbors(self.searcher.path.end()):
110            self.problem.show_node(self.ax, neigh.to_node, color)
111
112    def auto(self, event):
113        self.click = 1
114
115    def step(self, event):
116        self.click = 2
117
118    def finestep(self, event):
119        self.click = 3
120
121    def quit(self, event):
122        quit()
123
124    class ExitToPython(Exception):
125        pass

```

searchGUI.py — (continued)

```

123 from searchGeneric import Searcher, AStarSearcher
124 from searchMPP import SearcherMPP
125 import searchExample
126 from searchBranchAndBound import DF_branch_and_bound
127
128 # to demonstrate depth-first search:
129 # sdfs = SearcherGUI(Searcher, searchExample.tree_graph); sdfs.go()
130
131 # delivery graph examples:
132 # sh = SearcherGUI(Searcher, searchExample.simp_delivery_graph); sh.go()

```

```

133 # sha = SearcherGUI(AStarSearcher, searchExample.simp_delivery_graph);
      sha.go()
134 # shac = SearcherGUI(AStarSearcher,
      searchExample.cyclic_simp_delivery_graph); shac.go()
135 # shm = SearcherGUI(SearcherMPP,
      searchExample.cyclic_simp_delivery_graph); shm.go()
136 # shb = SearcherGUI(DF_branch_and_bound,
      searchExample.simp_delivery_graph); shb.go()
137
138 # The following is AI:FCA figure 3.15, and is useful to show branch&bound:
139 # shbt = SearcherGUI(DF_branch_and_bound, searchExample.tree_graph);
      shbt.go()

```

### 3.2.3 Frontier as a Priority Queue

In many of the search algorithms, such as  $A^*$  and other best-first searchers, the frontier is implemented as a priority queue. The following code uses the Python's built-in priority queue implementations, `heapq`.

Following the lead of the Python documentation, <https://docs.python.org/3/library/heapq.html>, a frontier is a list of triples. The first element of each triple is the value to be minimized. The second element is a unique index which specifies the order that the elements were added to the queue, and the third element is the path that is on the queue. The use of the unique index ensures that the priority queue implementation does not compare paths; whether one path is less than another is not defined. It also lets us control what sort of search (e.g., depth-first or breadth-first) occurs when the value to be minimized does not give a unique next path.

The variable `frontier_index` is the total number of elements of the frontier that have been created. As well as being used as the unique index, it is useful for statistics, particularly in conjunction with the current size of the frontier.

```

----- searchGeneric.py --- (continued) -----
68 import heapq      # part of the Python standard library
69 from searchProblem import Path
70
71 class FrontierPQ(object):
72     """A frontier consists of a priority queue (heap), frontierpq, of
73         (value, index, path) triples, where
74         * value is the value we want to minimize (e.g., path cost + h).
75         * index is a unique index for each element
76         * path is the path on the queue
77         Note that the priority queue always returns the smallest element.
78         """
79
80     def __init__(self):
81         """constructs the frontier, initially an empty priority queue
82         """
83         self.frontier_index = 0 # the number of items added to the frontier

```

```

84     self.frontierpq = [] # the frontier priority queue
85
86     def empty(self):
87         """is True if the priority queue is empty"""
88         return self.frontierpq == []
89
90     def add(self, path, value):
91         """add a path to the priority queue
92         value is the value to be minimized"""
93         self.frontier_index += 1 # get a new unique index
94         heapq.heappush(self.frontierpq, (value, -self.frontier_index, path))
95
96     def pop(self):
97         """returns and removes the path of the frontier with minimum value.
98         """
99         (_,_,path) = heapq.heappop(self.frontierpq)
100        return path

```

The following methods are used for finding and printing information about the frontier.

```

searchGeneric.py — (continued)
102     def count(self, val):
103         """returns the number of elements of the frontier with value=val"""
104         return sum(1 for e in self.frontierpq if e[0]==val)
105
106     def __repr__(self):
107         """string representation of the frontier"""
108         return str([(n,c,str(p)) for (n,c,p) in self.frontierpq])
109
110     def __len__(self):
111         """length of the frontier"""
112         return len(self.frontierpq)
113
114     def __iter__(self):
115         """iterate through the paths in the frontier"""
116         for (_,_,path) in self.frontierpq:
117             yield path

```

### 3.2.4 A\* Search

For an A\* Search the frontier is implemented using the FrontierPQ class.

```

searchGeneric.py — (continued)
119 class AStarSearcher(Searcher):
120     """returns a searcher for a problem.
121     Paths can be found by repeatedly calling search().
122     """
123
124     def __init__(self, problem):

```

```

125         super().__init__(problem)
126
127     def initialize_frontier(self):
128         self.frontier = FrontierPQ()
129
130     def empty_frontier(self):
131         return self.frontier.empty()
132
133     def add_to_frontier(self,path):
134         """add path to the frontier with the appropriate cost"""
135         value = path.cost+self.problem.heuristic(path.end())
136         self.frontier.add(path, value)

```

Code should always be tested. The following provides a simple **unit test**, using `problem1` as the default problem.

```

searchGeneric.py — (continued)
138 import searchExample
139
140 def test(SearchClass, problem=searchExample.problem1,
141         solutions=[[ 'G', 'D', 'B', 'C', 'A' ]]):
142     """Unit test for aipython searching algorithms.
143     SearchClass is a class that takes a problem and implements search()
144     problem is a search problem
145     solutions is a list of optimal solutions
146     """
147     print("Testing problem 1:")
148     schr1 = SearchClass(problem)
149     path1 = schr1.search()
150     print("Path found:",path1)
151     assert path1 is not None, "No path is found in problem1"
152     assert list(path1.nodes()) in solutions, "Shortest path not found in
153         problem1"
154     print("Passed unit test")
155
156 if __name__ == "__main__":
157     #test(Searcher) # what needs to be changed to make this succeed?
158     test(AStarSearcher)
159
160 # example queries:
161 # searcher1 = Searcher(searchExample.simp_delivery_graph) # DFS
162 # searcher1.search() # find first path
163 # searcher1.search() # find next path
164 # searcher2 = AStarSearcher(searchExample.simp_delivery_graph) # A*
165 # searcher2.search() # find first path
166 # searcher2.search() # find next path
167 # searcher3 = Searcher(searchExample.cyclic_simp_delivery_graph) # DFS
168 # searcher3.search() # find first path with DFS. What do you expect to
169     happen?
170 # searcher4 = AStarSearcher(searchExample.cyclic_simp_delivery_graph) # A*
171 # searcher4.search() # find first path

```

**Exercise 3.2** Change the code so that it implements (i) best-first search and (ii) lowest-cost-first search. For each of these methods compare it to  $A^*$  in terms of the number of paths expanded, and the path found.

**Exercise 3.3** The searcher acts like a Python iterator, in that it returns one value (here a path) and then returns other values (paths) on demand, but does not implement the iterator interface. Change the code so it implements the iterator interface. What does this enable us to do?

### 3.2.5 Multiple Path Pruning

To run the multiple-path pruning demo, in folder “aipython”, load “searchMPP.py”, using e.g., `ipython -i searchMPP.py`, and copy and paste the example queries at the bottom of that file.

The following implements  $A^*$  with multiple-path pruning. It overrides `search()` in `Searcher`.

```

searchMPP.py — Searcher with multiple-path pruning
11 from searchGeneric import AStarSearcher
12 from searchProblem import Path
13
14 class SearcherMPP(AStarSearcher):
15     """returns a searcher for a problem.
16     Paths can be found by repeatedly calling search().
17     """
18     def __init__(self, problem):
19         super().__init__(problem)
20         self.explored = set()
21
22     def search(self):
23         """returns next path from an element of problem's start nodes
24         to a goal node.
25         Returns None if no path exists.
26         """
27         while not self.empty_frontier():
28             self.path = self.frontier.pop()
29             if self.path.end() not in self.explored:
30                 self.explored.add(self.path.end())
31                 self.num_expanded += 1
32                 if self.problem.is_goal(self.path.end()):
33                     self.solution = self.path # store the solution found
34                     self.display(1, f"Solution: {self.path} (cost:
35                               {self.path.cost})\n",
36                               self.num_expanded, "paths have been expanded and",
37                               len(self.frontier), "paths remain in the
38                               frontier")
39                     return self.path
39         else:

```

```

39         self.display(4, f"Expanding: {self.path} (cost:
        {self.path.cost}")
40         neighs = self.problem.neighbors(self.path.end())
41         self.display(2, f"Expanding: {self.path} with neighbors
        {neighs}")
42         for arc in neighs:
43             self.add_to_frontier(Path(self.path, arc))
44         self.display(3, f"New frontier: {[p.end() for p in
        self.frontier]}")
45         self.display(0, "No (more) solutions. Total of",
46                     self.num_expanded, "paths expanded.")
47
48 from searchGeneric import test
49 if __name__ == "__main__":
50     test(SearcherMPP)
51
52 import searchExample
53 # searcherMPPcdp = SearcherMPP(searchExample.cyclic_simp_delivery_graph)
54 # searcherMPPcdp.search() # find first path

```

**Exercise 3.4** Chris was very puzzled as to why there was a minus (“-”) in the second element of the tuple added to the heap in the add method in FrontierPQ in searchGeneric.py.

Sam suggested the following example would demonstrate the importance of the minus. Consider an infinite integer grid, where the states are pairs of integers, the start is (0,0), and the goal is (10,10). The neighbors of  $(i, j)$  are  $(i + 1, j)$  and  $(i, j + 1)$ . Consider the heuristic function  $h((i, j)) = |10 - i| + |10 - j|$ . Sam suggested you compare how many paths are expanded with the minus and without the minus. searchGrid is a representation of Sam’s graph. If something takes too long, you might consider changing the size.

```

_____ searchGrid.py — A grid problem to demonstrate A* _____
11 from searchProblem import Search_problem, Arc
12
13 class GridProblem(Search_problem):
14     """a node is a pair (x,y)"""
15     def __init__(self, size=10):
16         self.size = size
17
18     def start_node(self):
19         """returns the start node"""
20         return (0,0)
21
22     def is_goal(self, node):
23         """returns True when node is a goal node"""
24         return node == (self.size, self.size)
25
26     def neighbors(self, node):
27         """returns a list of the neighbors of node"""
28         (x,y) = node

```

```

29         return [Arc(node, (x+1,y)), Arc(node, (x,y+1))]
30
31     def heuristic(self,node):
32         (x,y) = node
33         return abs(x-self.size)+abs(y-self.size)
34
35 class GridProblemNH(GridProblem):
36     """Grid problem with a heuristic of 0"""
37     def heuristic(self,node):
38         return 0
39
40 from searchGeneric import Searcher, AStarSearcher
41 from searchMPP import SearcherMPP
42 from searchBranchAndBound import DF_branch_and_bound
43
44 def testGrid(size = 10):
45     print("\nWith MPP")
46     gridsearchermpp = SearcherMPP(GridProblem(size))
47     print(gridsearchermpp.search())
48     print("\nWithout MPP")
49     gridsearchera = AStarSearcher(GridProblem(size))
50     print(gridsearchera.search())
51     print("\nWith MPP and a heuristic = 0 (Dijkstra's algorithm)")
52     gridsearchermppnh = SearcherMPP(GridProblemNH(size))
53     print(gridsearchermppnh.search())

```

Explain to Chris what the minus does and why it is there. Give evidence for your claims. It might be useful to refer to other search strategies in your explanation. As part of your explanation, explain what is special about Sam’s example.

**Exercise 3.5** Implement a searcher that implements cycle pruning instead of multiple-path pruning. You need to decide whether to check for cycles when paths are added to the frontier or when they are removed. (Hint: either method can be implemented by only changing one or two lines in SearcherMPP. Hint: there is a cycle if `path.end()` in `path.initial_nodes()`) Compare no pruning, multiple path pruning and cycle pruning for the cyclic delivery problem. Which works better in terms of number of paths expanded, computational time or space?

### 3.3 Branch-and-bound Search

To run the demo, in folder “aipython”, load “searchBranchAndBound.py”, and copy and paste the example queries at the bottom of that file.

Depth-first search methods do not need a priority queue, but can use a list as a stack. In this implementation of branch-and-bound search, we call *search* to find an optimal solution with cost less than bound. This uses depth-first search to find a path to a goal that extends *path* with cost less than the bound.

Once a path to a goal has been found, that path is remembered as the *best\_path*, the bound is reduced, and the search continues.

```

searchBranchAndBound.py — Branch and Bound Search
11 from searchProblem import Path
12 from searchGeneric import Searcher
13 from display import Displayable
14
15 class DF_branch_and_bound(Searcher):
16     """returns a branch and bound searcher for a problem.
17     An optimal path with cost less than bound can be found by calling
18     search()
19     """
20     def __init__(self, problem, bound=float("inf")):
21         """creates a searcher than can be used with search() to find an
22         optimal path.
23         bound gives the initial bound. By default this is infinite -
24         meaning there
25         is no initial pruning due to depth bound
26         """
27         super().__init__(problem)
28         self.best_path = None
29         self.bound = bound
30
31     def search(self):
32         """returns an optimal solution to a problem with cost less than
33         bound.
34         returns None if there is no solution with cost less than bound."""
35         self.frontier = [Path(self.problem.start_node())]
36         self.num_expanded = 0
37         while self.frontier:
38             self.path = self.frontier.pop()
39             if self.path.cost+self.problem.heuristic(self.path.end()) <
40                 self.bound:
41                 # if self.path.end() not in self.path.initial_nodes(): # for
42                 # cycle pruning
43                 self.display(2,"Expanding:",self.path,"cost:",self.path.cost)
44                 self.num_expanded += 1
45                 if self.problem.is_goal(self.path.end()):
46                     self.best_path = self.path
47                     self.bound = self.path.cost
48                     self.display(1,"New best path:",self.path,"
49                     cost:",self.path.cost)
50                 else:
51                     neighs = self.problem.neighbors(self.path.end())
52                     self.display(4,"Neighbors are", neighs)
53                     for arc in reversed(list(neighs)):
54                         self.add_to_frontier(Path(self.path, arc))
55                     self.display(3, f"New frontier: {[p.end() for p in
56                     self.frontier]}")
57         self.path = self.best_path

```

```

50     self.solution = self.best_path
51     self.display(1,f"Optimal solution is {self.best_path}." if
        self.best_path
52         else "No solution found.",
53         f"Number of paths expanded: {self.num_expanded}.")
54     return self.best_path

```

Note that this code used *reversed* in order to expand the neighbors of a node in the left-to-right order one might expect. It does this because *pop()* removes the rightmost element of the list. The call to *list* is there because *reversed* only works on lists and tuples, but the neighbors can be generated.

Here is a unit test and some queries:

```

_____searchBranchAndBound.py — (continued)_____
56 from searchGeneric import test
57 if __name__ == "__main__":
58     test(DF_branch_and_bound)
59
60 # Example queries:
61 import searchExample
62 # searcherb1 = DF_branch_and_bound(searchExample.simp_delivery_graph)
63 # searcherb1.search() # find optimal path
64 # searcherb2 =
        DF_branch_and_bound(searchExample.cyclic_simp_delivery_graph,
        bound=100)
65 # searcherb2.search() # find optimal path

```

**Exercise 3.6** In *searcherb2*, in the code above, what happens if the bound is smaller, say 10? What if it is larger, say 1000?

**Exercise 3.7** Implement a branch-and-bound search using recursion. Hint: you don't need an explicit frontier, but can do a recursive call for the children.

**Exercise 3.8** After the branch-and-bound search found a solution, Sam ran search again, and noticed a different count. Sam hypothesized that this count was related to the number of nodes that an *A\** search would use (either expand or be added to the frontier). Or maybe, Sam thought, the count for a number of nodes when the bound is slightly above the optimal path case is related to how *A\** would work. Is there a relationship between these counts? Are there different things that it could count so they are related? Try to find the most specific statement that is true, and explain why it is true.

To test the hypothesis, Sam wrote the following code, but isn't sure it is helpful:

```

_____searchTest.py — code that may be useful to compare A* and branch-and-bound_____
11 from searchGeneric import Searcher, AStarSearcher
12 from searchBranchAndBound import DF_branch_and_bound
13 from searchMPP import SearcherMPP
14
15 DF_branch_and_bound.max_display_level = 1
16 Searcher.max_display_level = 1

```

```

17
18 def run(problem,name):
19     print("\n\n*****",name)
20
21     print("\nA*:")
22     asearcher = AStarSearcher(problem)
23     print("Path found:",asearcher.search()," cost=",asearcher.solution.cost)
24     print("there are",asearcher.frontier.count(asearcher.solution.cost),
25           "elements remaining on the queue with
26           f-value=",asearcher.solution.cost)
27
28     print("\nA* with MPP:"),
29     msearcher = SearcherMPP(problem)
30     print("Path found:",msearcher.search()," cost=",msearcher.solution.cost)
31     print("there are",msearcher.frontier.count(msearcher.solution.cost),
32           "elements remaining on the queue with
33           f-value=",msearcher.solution.cost)
34
35     bound = asearcher.solution.cost+0.01
36     print("\nBranch and bound (with too-good initial bound of", bound,")")
37     tbb = DF_branch_and_bound(problem,bound) # cheating!!!!
38     print("Path found:",tbb.search()," cost=",tbb.solution.cost)
39     print("Rerunning B&B")
40     print("Path found:",tbb.search())
41
42     bbound = asearcher.solution.cost*2+10
43     print("\nBranch and bound (with not-very-good initial bound of",
44           bbound, ")")
45     tbb2 = DF_branch_and_bound(problem,bbound)
46     print("Path found:",tbb2.search()," cost=",tbb2.solution.cost)
47     print("Rerunning B&B")
48     print("Path found:",tbb2.search())
49
50     print("\nDepth-first search: (Use ^C if it goes on forever)")
51     tsearcher = Searcher(problem)
52     print("Path found:",tsearcher.search()," cost=",tsearcher.solution.cost)
53
54 import searchExample
55 from searchTest import run
56 if __name__ == "__main__":
57     run(searchExample.problem1,"Problem 1")
58     # run(searchExample.simp_delivery_graph,"Acyclic Delivery")
59     # run(searchExample.cyclic_simp_delivery_graph,"Cyclic Delivery")
60     # also test some graphs with cycles, and some with multiple least-cost
61     paths

```



## Reasoning with Constraints

### 4.1 Constraint Satisfaction Problems

#### 4.1.1 Variables

A **variable** consists of a name, a domain and an optional (x,y) position (for displaying). The domain of a variable is a list or a tuple, as the ordering will matter in the representation of constraints.

```
_____variable.py — Representations of a variable in CSPs and probabilistic models _____
11 import random
12
13 class Variable(object):
14     """A random variable.
15     name (string) - name of the variable
16     domain (list) - a list of the values for the variable.
17     Variables are ordered according to their name.
18     """
19
20     def __init__(self, name, domain, position=None):
21         """Variable
22         name a string
23         domain a list of printable values
24         position of form (x,y)
25         """
26         self.name = name # string
27         self.domain = domain # list of values
28         self.position = position if position else (random.random(),
29             random.random())
30         self.size = len(domain)
31     def __str__(self):
```

```

32     return self.name
33
34     def __repr__(self):
35         return self.name # f"Variable({self.name})"

```

### 4.1.2 Constraints

A **constraint** consists of:

- A tuple (or list) of variables called the **scope**.
- A **condition**, a Boolean function that takes the same number of arguments as there are variables in the scope. The condition must have a `__name__` property that gives a printable name of the function; built-in functions and functions that are defined using *def* have such a property; for other functions you may need to define this property.
- An optional name
- An optional  $(x, y)$  position

```

_____cspProblem.py — Representations of a Constraint Satisfaction Problem_____
11 from variable import Variable
12
13 # for showing csps:
14 import matplotlib.pyplot as plt
15 import matplotlib.lines as lines
16
17 class Constraint(object):
18     """A Constraint consists of
19     * scope: a tuple of variables
20     * condition: a Boolean function that can applied to a tuple of values
21       for variables in scope
22     * string: a string for printing the constraints. All of the strings
23       must be unique.
24     for the variables
25     """
26     def __init__(self, scope, condition, string=None, position=None):
27         self.scope = scope
28         self.condition = condition
29         if string is None:
30             self.string = f"{self.condition.__name__}({self.scope})"
31         else:
32             self.string = string
33             self.position = position
34
35     def __repr__(self):
36         return self.string

```

An **assignment** is a *variable:value* dictionary.

If *con* is a constraint, *con.holds(assignment)* returns True or False depending on whether the condition is true or false for that assignment. The assignment *assignment* must assign a value to every variable in the scope of the constraint *con* (and could also assign values to other variables); *con.holds* gives an error if not all variables in the scope of *con* are assigned in the assignment. It ignores variables in *assignment* that are not in the scope of the constraint.

In Python, the *\** notation is used for unpacking a tuple. For example, *F(\*(1,2,3))* is the same as *F(1,2,3)*. So if *t* has value (1,2,3), then *F(\*t)* is the same as *F(1,2,3)*.

```

cspProblem.py — (continued)
36 def can_evaluate(self, assignment):
37     """
38     assignment is a variable:value dictionary
39     returns True if the constraint can be evaluated given assignment
40     """
41     return all(v in assignment for v in self.scope)
42
43 def holds(self, assignment):
44     """returns the value of Constraint con evaluated in assignment.
45
46     precondition: all variables are assigned in assignment, ie
47     self.can_evaluate(assignment) is true
48     """
49     return self.condition(*tuple(assignment[v] for v in self.scope))

```

### 4.1.3 CSPs

A constraint satisfaction problem (CSP) requires:

- *variables*: a list or set of variables
- *constraints*: a set or list of constraints.

Other properties are inferred from these:

- *var\_to\_const* is a mapping from variables to set of constraints, such that *var\_to\_const[var]* is the set of constraints with *var* in the scope.

```

cspProblem.py — (continued)
50 class CSP(object):
51     """A CSP consists of
52     * a title (a string)
53     * variables, a set of variables
54     * constraints, a list of constraints
55     * var_to_const, a variable to set of constraints dictionary
56     """

```

```

57 def __init__(self, title, variables, constraints):
58     """title is a string
59     variables is set of variables
60     constraints is a list of constraints
61     """
62     self.title = title
63     self.variables = variables
64     self.constraints = constraints
65     self.var_to_const = {var:set() for var in self.variables}
66     for con in constraints:
67         for var in con.scope:
68             self.var_to_const[var].add(con)
69
70 def __str__(self):
71     """string representation of CSP"""
72     return str(self.title)
73
74 def __repr__(self):
75     """more detailed string representation of CSP"""
76     return f"CSP({self.title}, {self.variables}, {[str(c) for c in
        self.constraints]}))"

```

`csp.consistent(assignment)` returns true if the assignment is consistent with each of the constraints in `csp` (i.e., all of the constraints that can be evaluated evaluate to true). Note that this is a local consistency with each constraint; it does *not* imply the CSP is consistent or has a solution.

cspProblem.py — (continued)

```

78 def consistent(self, assignment):
79     """assignment is a variable:value dictionary
80     returns True if all of the constraints that can be evaluated
81         evaluate to True given assignment.
82     """
83     return all(con.holds(assignment)
84               for con in self.constraints
85               if con.can_evaluate(assignment))

```

The `show` method uses matplotlib to show the graphical structure of a constraint network. If the node positions are not specified, this gives different positions each time it is run; if you don't like the graph, try again.

cspProblem.py — (continued)

```

87 def show(self, linewidth=3, showDomains=False, showAutoAC = False):
88     self.linewidth = linewidth
89     self.picked = None
90     plt.ion() # interactive
91     self.arcs = {} # arc: (con,var) dictionary
92     self.thelines = {} # (con,var):arc dictionary
93     self.nodes = {} # node: variable dictionary
94     self.fig, self.ax= plt.subplots(1, 1)
95     self.ax.set_axis_off()

```

```

96     for var in self.variables:
97         if var.position is None:
98             var.position = (random.random(), random.random())
99     self.showAutoAC = showAutoAC # used for consistency GUI
100    self.autoAC = False
101    domains = {var:var.domain for var in self.variables} if showDomains
102                else {}
103    self.draw_graph(domains=domains)
104
105    def draw_graph(self, domains={}, to_do = {}, title=None, fontsize=10):
106        self.ax.clear()
107        self.ax.set_axis_off()
108        if title:
109            plt.title(title, fontsize=fontsize)
110        else:
111            plt.title(self.title, fontsize=fontsize)
112        var_bbox = dict(boxstyle="round4,pad=1.0,rounding_size=0.5")
113        con_bbox = dict(boxstyle="square,pad=1.0",color="green")
114        self.autoACtext = plt.text(0,0,"Auto AC" if self.showAutoAC else "",
115                                   bbox={'boxstyle':'square','color':'yellow'},
116                                   picker=True, fontsize=fontsize)
117        for con in self.constraints:
118            if con.position is None:
119                con.position = tuple(sum(var.position[i] for var in
120                                       con.scope)/len(con.scope)
121                                   for i in range(2))
122            cx,cy = con.position
123            bbox = dict(boxstyle="square,pad=1.0",color="green")
124            for var in con.scope:
125                vx,vy = var.position
126                if (var,con) in to_do:
127                    color = 'blue'
128                else:
129                    color = 'limegreen'
130                line = lines.Line2D([cx,vx], [cy,vy], axes=self.ax,
131                                   color=color,
132                                   picker=True, pickradius=10,
133                                   linewidth=self.linewidth)
134                self.arcs[line]= (var,con)
135                self.thelines[(var,con)] = line
136                self.ax.add_line(line)
137            plt.text(cx,cy,con.string,
138                    bbox=con_bbox,
139                    ha='center',va='center', fontsize=fontsize)
140        for var in self.variables:
141            x,y = var.position
142            if domains:
143                node_label = f"{var.name}\n{domains[var]}"
144            else:
145                node_label = var.name

```

```

142         node = plt.text(x, y, node_label, bbox=var_bbox, ha='center',
143                        va='center',
144                        picker=True, fontsize=fontsize)
145         self.nodes[node] = var
146         self.fig.canvas.mpl_connect('pick_event', self.pick_handler)
147
148     def pick_handler(self, event):
149         mouseevent = event.mouseevent
150         self.last_artist = artist = event.artist
151         #print('***picker handler:', artist, 'mouseevent:', mouseevent)
152         if artist in self.arcs:
153             #print('### selected arc', self.arcs[artist])
154             self.picked = self.arcs[artist]
155         elif artist in self.nodes:
156             #print('### selected node', self.nodes[artist])
157             self.picked = self.nodes[artist]
158         elif artist==self.autoACtext:
159             self.autoAC = True
160             #print("*** autoAC")
161         else:
162             print("### unknown click")

```

#### 4.1.4 Examples

In the following code *ne\_*, when given a number, returns a function that is true when its argument is not that number. For example, if  $f = ne_3$ , then  $f(2)$  is True and  $f(3)$  is False. That is,  $ne_3(x)(y)$  is true when  $x \neq y$ . Allowing a function of multiple arguments to use its arguments one at a time is called **currying**, after the logician Haskell Curry. Functions used as conditions in constraints require names (so they can be printed).

```

cspExamples.py — Example CSPs
11 from cspProblem import Variable, CSP, Constraint
12 from operator import lt, ne, eq, gt
13
14 def ne_(val):
15     """not equal value"""
16     # nev = lambda x: x != val # alternative definition
17     # nev = partial(neq, val) # another alternative definition
18     def nev(x):
19         return val != x
20     nev.__name__ = f"{val} != " # name of the function
21     return nev

```

Similarly  $is_3(x)(y)$  is true when  $x = y$ .

```

cspExamples.py — (continued)
23 def is_(val):
24     """is a value"""
25     # isv = lambda x: x == val # alternative definition

```

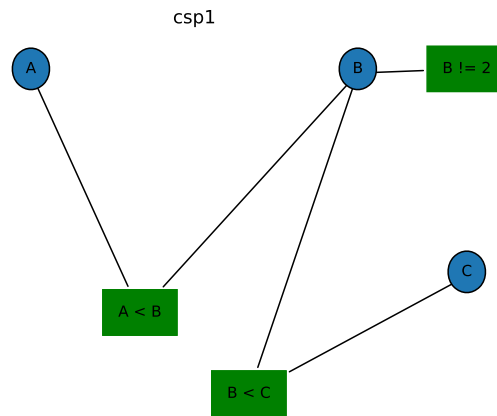
Figure 4.1: `csp1.show()`

```

26 # isv = partial(eq,val) # another alternative definition
27 def isv(x):
28     return val == x
29     isv.__name__ = f"{val} == "
30     return isv

```

The CSP, `csp0` has variables  $X$ ,  $Y$  and  $Z$ , each with domain  $\{1,2,3\}$ . The constraints are  $X < Y$  and  $Y < Z$ .

```

_____cspExamples.py — (continued) _____
32 X = Variable('X', {1,2,3})
33 Y = Variable('Y', {1,2,3})
34 Z = Variable('Z', {1,2,3})
35 csp0 = CSP("csp0", {X,Y,Z},
36         [ Constraint([X,Y],lt),
37           Constraint([Y,Z],lt)])

```

The CSP, `csp1` has variables  $A$ ,  $B$  and  $C$ , each with domain  $\{1,2,3,4\}$ . The constraints are  $A < B$ ,  $B \neq 2$ , and  $B < C$ . This is slightly more interesting than `csp0` as it has more solutions. This example is used in the unit tests, and so if it is changed, the unit tests need to be changed. The CSP `csp1s` is the same, but with only the constraints  $A < B$  and  $B < C$

```

_____cspExamples.py — (continued) _____
39 A = Variable('A', {1,2,3,4}, position=(0.2,0.9))
40 B = Variable('B', {1,2,3,4}, position=(0.8,0.9))
41 C = Variable('C', {1,2,3,4}, position=(1,0.4))
42 C0 = Constraint([A,B], lt, "A < B", position=(0.4,0.3))
43 C1 = Constraint([B], ne_(2), "B != 2", position=(1,0.9))
44 C2 = Constraint([B,C], lt, "B < C", position=(0.6,0.1))

```

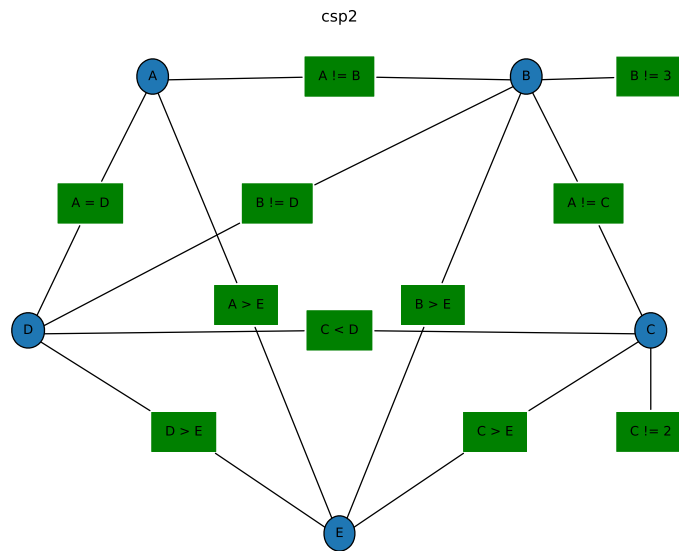
Figure 4.2: `csp2.show()`

```

45 | csp1 = CSP("csp1", {A, B, C},
46 |         [C0, C1, C2])
47 |
48 | csp1s = CSP("csp1s", {A, B, C},
49 |            [C0, C2]) # A<B, B<C

```

The next CSP, *csp2* is Example 4.9 of Poole and Mackworth [2023]; the domain consistent network (after applying the unary constraints) is shown in Figure 4.2. Note that we use the same variables as the previous example and add two more.

```

cspExamples.py — (continued)
51 | D = Variable('D', {1,2,3,4}, position=(0,0.4))
52 | E = Variable('E', {1,2,3,4}, position=(0.5,0))
53 | csp2 = CSP("csp2", {A,B,C,D,E},
54 |          [ Constraint([B], ne_(3), "B != 3", position=(1,0.9)),
55 |            Constraint([C], ne_(2), "C != 2", position=(1,0.2)),
56 |            Constraint([A,B], ne, "A != B"),
57 |            Constraint([B,C], ne, "A != C"),
58 |            Constraint([C,D], lt, "C < D"),
59 |            Constraint([A,D], eq, "A = D"),
60 |            Constraint([E,A], lt, "E < A"),
61 |            Constraint([E,B], lt, "E < B"),
62 |            Constraint([E,C], lt, "E < C"),
63 |            Constraint([E,D], lt, "E < D"),

```

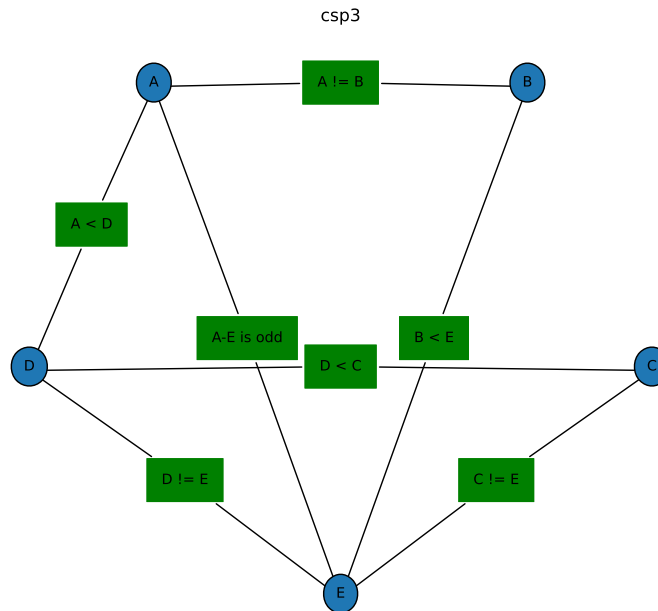

Figure 4.3: csp3.show()

```
64 | Constraint([B,D], ne, "B != D"])
```

The following example is another scheduling problem (but with multiple answers). This is the same as “scheduling 2” in the original AIspace.org consistency app.

```

_____cspExamples.py — (continued)_____
66 | csp3 = CSP("csp3", {A,B,C,D,E},
67 |     Constraint([A,B], ne, "A != B"),
68 |     Constraint([A,D], lt, "A < D"),
69 |     Constraint([A,E], lambda a,e: (a-e)%2 == 1, "A-E is odd"),
70 |     Constraint([B,E], lt, "B < E"),
71 |     Constraint([D,C], lt, "D < C"),
72 |     Constraint([C,E], ne, "C != E"),
73 |     Constraint([D,E], ne, "D != E"))

```

The following example is another abstract scheduling problem. What are the solutions?

```

_____cspExamples.py — (continued)_____
75 | def adjacent(x,y):
76 |     """True when x and y are adjacent numbers"""
77 |     return abs(x-y) == 1

```

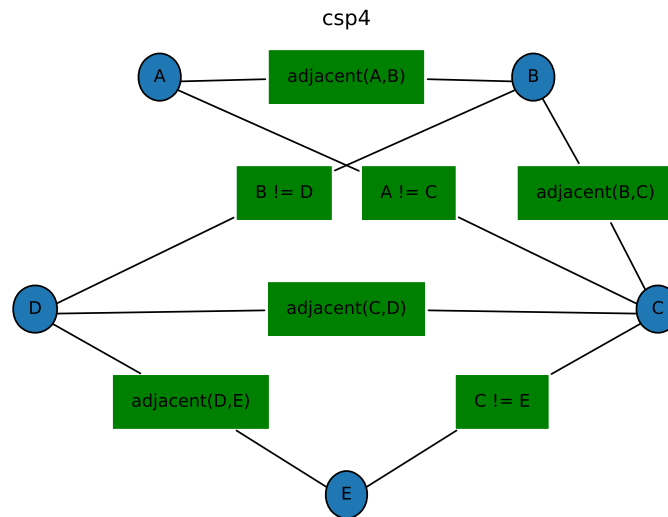

Figure 4.4: csp4.show()

```

78 |
79 | csp4 = CSP("csp4", {A,B,C,D},
80 |         [Constraint([A,B], adjacent, "adjacent(A,B)"),
81 |           Constraint([B,C], adjacent, "adjacent(B,C)"),
82 |           Constraint([C,D], adjacent, "adjacent(C,D)"),
83 |           Constraint([A,C], ne, "A != C"),
84 |           Constraint([B,D], ne, "B != D") ])

```

The following examples represent the crossword shown in Figure 4.5.

In the first representation, the variables represent words. The constraint imposed by the crossword is that where two words intersect, the letter at the intersection must be the same. The method `meet_at` is used to test whether two words intersect with the same letter. For example, the constraint `meet_at(2,0)` means that the third letter (at position 2) of the first argument is the same as the first letter of the second argument. This is shown in Figure 4.6.

cspExamples.py — (continued)

```

86 | def meet_at(p1,p2):
87 |     """returns a function of two words that is true
88 |         when the words intersect at positions p1, p2.
89 |         The positions are relative to the words; starting at position 0.
90 |         meet_at(p1,p2)(w1,w2) is true if the same letter is at position p1 of
91 |         word w1
92 |         and at position p2 of word w2.
93 |     """
94 |     def meets(w1,w2):
95 |         return w1[p1] == w2[p2]

```

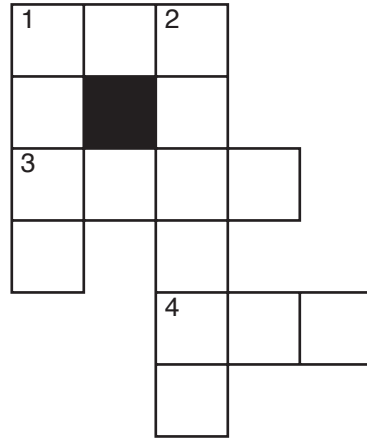

**Words:**  
 ant, big, bus, car, has,  
 book, buys, hold, lane,  
 year, ginger, search,  
 symbol, syntax.

Figure 4.5: crossword1: a crossword puzzle to be solved

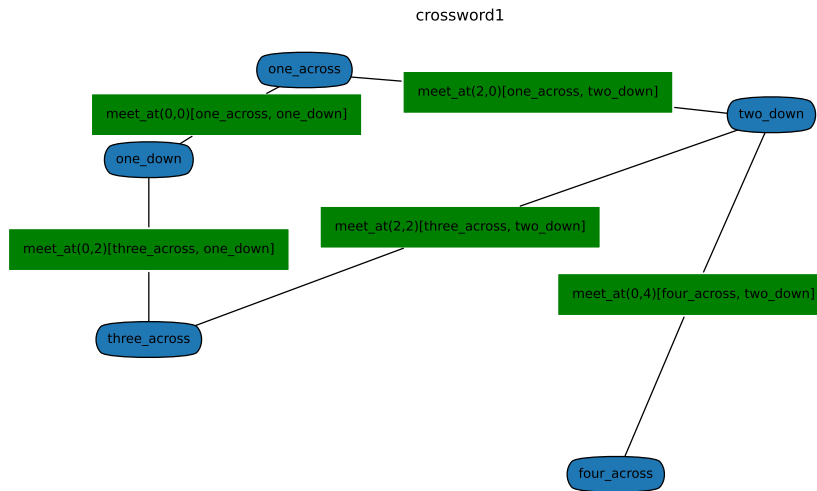

Figure 4.6: crossword1.show()

```

95     meets.__name__ = f"meet_at({p1},{p2})"
96     return meets
97
98 one_across = Variable('one_across', {'ant', 'big', 'bus', 'car', 'has'},
99     position=(0.3,0.9))
100 one_down = Variable('one_down', {'book', 'buys', 'hold', 'lane', 'year'},
101     position=(0.1,0.7))
102 two_down = Variable('two_down', {'ginger', 'search', 'symbol', 'syntax'},
103     position=(0.9,0.8))
104 three_across = Variable('three_across', {'book', 'buys', 'hold', 'land',
105     'year'}, position=(0.1,0.3))
106 four_across = Variable('four_across',{ 'ant', 'big', 'bus', 'car', 'has'},
107     position=(0.7,0.0))
108 crossword1 = CSP("crossword1",
109     {one_across, one_down, two_down, three_across,
110     four_across},
111     [Constraint([one_across,one_down], meet_at(0,0)),
112     Constraint([one_across,two_down], meet_at(2,0)),
113     Constraint([three_across,two_down], meet_at(2,2)),
114     Constraint([three_across,one_down], meet_at(0,2)),
115     Constraint([four_across,two_down], meet_at(0,4))])

```

In an alternative representation of a crossword (the “dual” representation), the variables represent letters, and the constraints are that adjacent sequences of letters form words. This is shown in Figure 4.7.

```

cspExamples.py — (continued)
111 words = {'ant', 'big', 'bus', 'car', 'has', 'book', 'buys', 'hold',
112     'lane', 'year', 'ginger', 'search', 'symbol', 'syntax'}
113
114 def is_word(*letters, words=words):
115     """is true if the letters concatenated form a word in words"""
116     return "".join(letters) in words
117
118 letters = {"a", "b", "c", "d", "e", "f", "g", "h", "i", "j", "k", "l",
119     "m", "n", "o", "p", "q", "r", "s", "t", "u", "v", "w", "x", "y",
120     "z"}
121
122 # pij is the variable representing the letter i from the left and j down
123     (starting from 0)
124 p00 = Variable('p00', letters, position=(0.1,0.85))
125 p10 = Variable('p10', letters, position=(0.3,0.85))
126 p20 = Variable('p20', letters, position=(0.5,0.85))
127 p01 = Variable('p01', letters, position=(0.1,0.7))
128 p21 = Variable('p21', letters, position=(0.5,0.7))
129 p02 = Variable('p02', letters, position=(0.1,0.55))
130 p12 = Variable('p12', letters, position=(0.3,0.55))
131 p22 = Variable('p22', letters, position=(0.5,0.55))
132 p32 = Variable('p32', letters, position=(0.7,0.55))
133 p03 = Variable('p03', letters, position=(0.1,0.4))
134 p23 = Variable('p23', letters, position=(0.5,0.4))

```

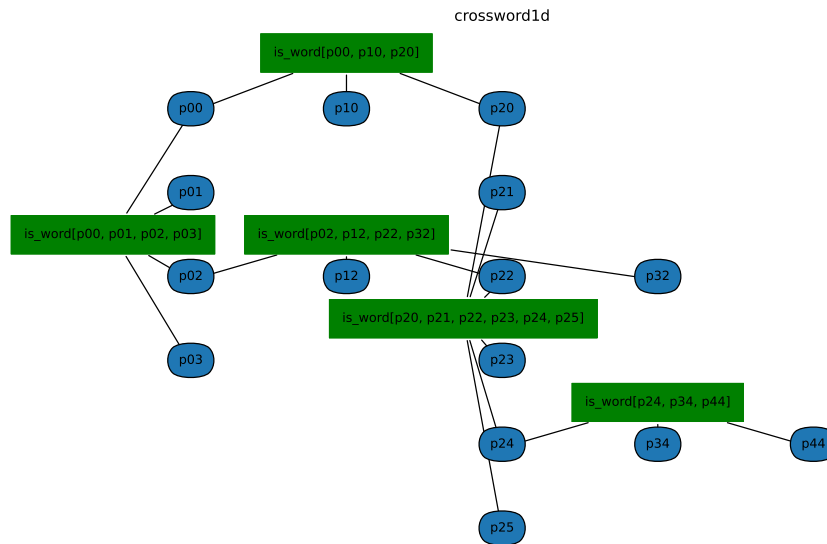

Figure 4.7: crossword1d.show()

```

134 p24 = Variable('p24', letters, position=(0.5,0.25))
135 p34 = Variable('p34', letters, position=(0.7,0.25))
136 p44 = Variable('p44', letters, position=(0.9,0.25))
137 p25 = Variable('p25', letters, position=(0.5,0.1))
138
139 crossword1d = CSP("crossword1d",
140     {p00, p10, p20, # first row
141     p01, p21, # second row
142     p02, p12, p22, p32, # third row
143     p03, p23, #fourth row
144     p24, p34, p44, # fifth row
145     p25 # sixth row
146     },
147     [Constraint([p00, p10, p20], is_word,
148                 position=(0.3,0.95)), #1-across
149     Constraint([p00, p01, p02, p03], is_word,
150                 position=(0,0.625)), # 1-down
151     Constraint([p02, p12, p22, p32], is_word,
152                 position=(0.3,0.625)), # 3-across
153     Constraint([p20, p21, p22, p23, p24, p25], is_word,
154                 position=(0.45,0.475)), # 2-down
155     Constraint([p24, p34, p44], is_word,
156                 position=(0.7,0.325)) # 4-across

```

152 |                                    ])

**Exercise 4.1** How many assignments of a value to each variable are there for each of the representations of the above crossword? Do you think an exhaustive enumeration will work for either one?

The queens problem is a puzzle on a chess board, where the idea is to place a queen on each column so the queens cannot take each other: there are no two queens on the same row, column or diagonal. The **n-queens problem** is a generalization where the size of the board is an  $n \times n$ , and  $n$  queens have to be placed.

Here is a representation of the n-queens problem, where the variables are the columns and the values are the rows in which the queen is placed. The original queens problem on a standard ( $8 \times 8$ ) chess board is `n_queens(8)`

```

_____cspExamples.py — (continued)_____
154 def queens(ri,rj):
155     """ri and rj are different rows, return the condition that the queens
        cannot take each other"""
156     def no_take(ci,cj):
157         """is true if queen at (ri,ci) cannot take a queen at (rj,cj)"""
158         return ci != cj and abs(ri-ci) != abs(rj-cj)
159     return no_take
160
161 def n_queens(n):
162     """returns a CSP for n-queens"""
163     columns = list(range(n))
164     variables = [Variable(f"R{i}",columns) for i in range(n)]
165     return CSP("n-queens",
166               variables,
167               [Constraint([variables[i], variables[j]], queens(i,j))
168                    for i in range(n) for j in range(n) if i != j])
169
170 # try the CSP n_queens(8) in one of the solvers.
171 # What is the smallest n for which there is a solution?

```

**Exercise 4.2** How many constraints does this representation of the n-queens problem produce? Can it be done with fewer constraints? Either explain why it can't be done with fewer constraints, or give a solution using fewer constraints.

### Unit tests

The following defines a **unit test** for csp solvers, by default using example `csp1`.

```

_____cspExamples.py — (continued)_____
173 def test_csp(CSP_solver, csp=csp1,
174             solutions=[{A: 1, B: 3, C: 4}, {A: 2, B: 3, C: 4}]):
175     """CSP_solver is a solver that takes a csp and returns a solution
176     csp is a constraint satisfaction problem
177     solutions is the list of all solutions to csp

```

```

178 |     This tests whether the solution returned by CSP_solver is a solution.
179 |     """
180 |     print("Testing csp with",CSP_solver.__doc__)
181 |     sol0 = CSP_solver(csp)
182 |     print("Solution found:",sol0)
183 |     assert sol0 in solutions, f"Solution not correct for {csp}"
184 |     print("Passed unit test")

```

**Exercise 4.3** Modify *test* so that instead of taking in a list of solutions, it checks whether the returned solution actually is a solution.

**Exercise 4.4** Propose a test that is appropriate for CSPs with no solutions. Assume that the test designer knows there are no solutions. Consider what a CSP solver should return if there are no solutions to the CSP.

**Exercise 4.5** Write a unit test that checks whether all solutions (e.g., for the search algorithms that can return multiple solutions) are correct, and whether all solutions can be found.

## 4.2 A Simple Depth-first Solver

The first solver carries out a depth-first search through the space of partial assignments. This takes in a CSP problem and an optional variable ordering (a list of the variables in the CSP). It returns a generator of the solutions (see Section 1.5.4 on `yield` for enumerations).

```

_____cspDFS.py — Solving a CSP using depth-first search. _____
11 | import cspExamples
12 |
13 | def dfs_solver(constraints, context, var_order):
14 |     """generator for all solutions to csp.
15 |     context is an assignment of values to some of the variables.
16 |     var_order is a list of the variables in csp that are not in context.
17 |     """
18 |     to_eval = {c for c in constraints if c.can_evaluate(context)}
19 |     if all(c.holds(context) for c in to_eval):
20 |         if var_order == []:
21 |             yield context
22 |         else:
23 |             rem_cons = [c for c in constraints if c not in to_eval]
24 |             var = var_order[0]
25 |             for val in var.domain:
26 |                 yield from dfs_solver(rem_cons, context|{var:val},
27 |                                     var_order[1:])
28 |
29 | def dfs_solve_all(csp, var_order=None):
30 |     """depth-first CSP solver to return a list of all solutions to csp.
31 |     """
32 |     if var_order == None: # use an arbitrary variable order
33 |         var_order = list(csp.variables)

```

```

33     return list( dfs_solver(csp.constraints, {}, var_order))
34
35 def dfs_solve1(csp, var_order=None):
36     """depth-first CSP solver"""
37     if var_order == None: # use an arbitrary variable order
38         var_order = list(csp.variables)
39     for sol in dfs_solver(csp.constraints, {}, var_order):
40         return sol #return first one
41
42 if __name__ == "__main__":
43     cspExamples.test_csp(dfs_solve1)
44
45 #Try:
46 # dfs_solve_all(cspExamples.csp1)
47 # dfs_solve_all(cspExamples.csp2)
48 # dfs_solve_all(cspExamples.crossword1)
49 # dfs_solve_all(cspExamples.crossword1d) # warning: may take a *very* long
    time!

```

**Exercise 4.6** Instead of testing all constraints at every node, change it so each constraint is only tested when all of its variables are assigned. Given an elimination ordering, it is possible to determine when each constraint needs to be tested. Implement this. Hint: create a parallel list of sets of constraints, where at each position  $i$  in the list, the constraints at position  $i$  can be evaluated when the variable at position  $i$  has been assigned.

**Exercise 4.7** Estimate how long `dfs_solve_all(crossword1d)` will take on your computer. To do this, reduce the number of variables that need to be assigned, so that the simplified problem can be solved in a reasonable time (between 0.1 second and 10 seconds). This can be done by reducing the number of variables in `var_order`, as the program only splits on these. How much more time will it take if the number of variables is increased by 1? (Try it!) Then extrapolate to all of the variables. See Section 1.6.1 for how to time your code. Would making the code 100 times faster or using a computer 100 times faster help?

### 4.3 Converting CSPs to Search Problems

To run the demo, in folder "aipython", load "cspSearch.py", and copy and paste the example queries at the bottom of that file.

The next solver constructs a search space that can be solved using the search methods of the previous chapter. This takes in a CSP problem and an optional variable ordering, which is a list of the variables in the CSP. In this search space:

- A node is a *variable : value* dictionary which does not violate any constraints (so that dictionaries that violate any constraints are not added).

- An arc corresponds to an assignment of a value to the next variable. This assumes a static ordering; the next variable chosen to split does not depend on the context. If no variable ordering is given, this makes no attempt to choose a good ordering.

```

_____cspSearch.py — Representations of a Search Problem from a CSP. _____
11 from cspProblem import CSP, Constraint
12 from searchProblem import Arc, Search_problem
13
14 class Search_from_CSP(Search_problem):
15     """A search problem directly from the CSP.
16
17     A node is a variable:value dictionary"""
18     def __init__(self, csp, variable_order=None):
19         self.csp=csp
20         if variable_order:
21             assert set(variable_order) == set(csp.variables)
22             assert len(variable_order) == len(csp.variables)
23             self.variables = variable_order
24         else:
25             self.variables = list(csp.variables)
26
27     def is_goal(self, node):
28         """returns whether the current node is a goal for the search
29         """
30         return len(node)==len(self.csp.variables)
31
32     def start_node(self):
33         """returns the start node for the search
34         """
35         return {}

```

The *neighbors(node)* method uses the fact that the length of the node, which is the number of variables already assigned, is the index of the next variable to split on. Note that we do not need to check whether there are no more variables to split on, as the nodes are all consistent, by construction, and so when there are no more variables we have a solution, and so don't need the neighbors.

```

_____cspSearch.py — (continued) _____
37 def neighbors(self, node):
38     """returns a list of the neighboring nodes of node.
39     """
40     var = self.variables[len(node)] # the next variable
41     res = []
42     for val in var.domain:
43         new_env = node|{var:val} #dictionary union
44         if self.csp.consistent(new_env):
45             res.append(Arc(node,new_env))
46     return res

```

The unit tests relies on a solver. The following procedure creates a solver using search that can be tested.

```

cspSearch.py — (continued)
48 import cspExamples
49 from searchGeneric import Searcher
50
51 def solver_from_searcher(csp):
52     """depth-first search solver"""
53     path = Searcher(Search_from_CSP(csp)).search()
54     if path is not None:
55         return path.end()
56     else:
57         return None
58
59 if __name__ == "__main__":
60     test_csp(solver_from_searcher)
61
62 ## Test Solving CSPs with Search:
63 searcher1 = Searcher(Search_from_CSP(cspExamples.csp1))
64 #print(searcher1.search()) # get next solution
65 searcher2 = Searcher(Search_from_CSP(cspExamples.csp2))
66 #print(searcher2.search()) # get next solution
67 searcher3 = Searcher(Search_from_CSP(cspExamples.crossword1))
68 #print(searcher3.search()) # get next solution
69 searcher4 = Searcher(Search_from_CSP(cspExamples.crossword1d))
70 #print(searcher4.search()) # get next solution (warning: slow)

```

**Exercise 4.8** What would happen if we constructed the new assignment by assigning  $node[var] = val$  (with side effects) instead of using dictionary union? Give an example of where this could give a wrong answer. How could the algorithm be changed to work with side effects? (Hint: think about what information needs to be in a node).

**Exercise 4.9** Change neighbors so that it returns an iterator of values rather than a list. (Hint: use *yield*.)

## 4.4 Consistency Algorithms

To run the demo, in folder "aipython", load "cspConsistency.py", and copy and paste the commented-out example queries at the bottom of that file.

A *Con\_solver* is used to simplify a CSP using arc consistency.

```

cspConsistency.py — Arc Consistency and Domain splitting for solving a CSP
11 from display import Displayable
12
13 class Con_solver(Displayable):

```

```

14     """Solves a CSP with arc consistency and domain splitting
15     """
16     def __init__(self, csp):
17         """a CSP solver that uses arc consistency
18         * csp is the CSP to be solved
19         """
20         self.csp = csp
21         super().__init__() # Or Displayable.__init__(self)

```

The following implementation of arc consistency maintains the set *to\_do* of (variable, constraint) pairs that are to be checked. It takes in a domain dictionary and returns a new domain dictionary. It needs to be careful to avoid side effects (by copying the *domains* dictionary and the *to\_do* set).

```

-----cspConsistency.py --- (continued) -----
23     def make_arc_consistent(self, domains=None, to_do=None):
24         """Makes this CSP arc-consistent using generalized arc consistency
25         domains is a variable:domain dictionary
26         to_do is a set of (variable,constraint) pairs
27         returns the reduced domains (an arc-consistent variable:domain
28         dictionary)
29         """
30         if domains is None:
31             self.domains = {var:var.domain for var in self.csp.variables}
32         else:
33             self.domains = domains.copy() # use a copy of domains
34         if to_do is None:
35             to_do = {(var, const) for const in self.csp.constraints
36                     for var in const.scope}
37         else:
38             to_do = to_do.copy() # use a copy of to_do
39         self.display(5, "Performing AC with domains", self.domains)
40         while to_do:
41             self.arc_selected = (var, const) = self.select_arc(to_do)
42             self.display(5, "Processing arc (", var, ", ", const, ")")
43             other_vars = [ov for ov in const.scope if ov != var]
44             new_domain = {val for val in self.domains[var]
45                           if self.any_holds(self.domains, const, {var:
46                                           val}, other_vars)}
47             if new_domain != self.domains[var]:
48                 self.add_to_do = self.new_to_do(var, const) - to_do
49                 self.display(3, f"Arc: ({var}, {const}) is inconsistent\n"
50                             f"Domain pruned, dom({var}) = {new_domain} due to
51                             {const}")
52                 self.domains[var] = new_domain
53                 self.display(4, " adding", self.add_to_do if self.add_to_do
54                             else "nothing", "to to_do.")
55                 to_do |= self.add_to_do # set union
56             self.display(5, f"Arc: ({var},{const}) now consistent")
57         self.display(5, "AC done. Reduced domains", self.domains)
58         return self.domains

```

```

56
57 def new_to_do(self, var, const):
58     """returns new elements to be added to to_do after assigning
59     variable var in constraint const.
60     """
61     return {(nvar, nconst) for nconst in self.csp.var_to_const[var]
62             if nconst != const
63             for nvar in nconst.scope
64             if nvar != var}

```

The following selects an arc. Any element of *to\_do* can be selected. The selected element needs to be removed from *to\_do*. The default implementation just selects which ever element *pop* method for sets returns. The graphical user interface below allows the user to select an arc. Alternatively, a more sophisticated selection could be employed.

```

                                     cspConsistency.py — (continued)
66 def select_arc(self, to_do):
67     """Selects the arc to be taken from to_do .
68     * to_do is a set of arcs, where an arc is a (variable,constraint)
69     pair
70     the element selected must be removed from to_do.
71     """
72     return to_do.pop()

```

The value of *new\_domain* is the subset of the domain of *var* that is consistent with the assignment to the other variables. To make it easier to understand, the following treats unary (with no other variables in the constraint) and binary (with one other variables in the constraint) constraints as special cases. These cases are not strictly necessary; the last case covers the first two cases, but is more difficult to understand without seeing the first two cases. Note that this case analysis is not in the code distribution, but can replace the assignment to *new\_domain* above.

```

    if len(other_vars)==0:           # unary constraint
        new_domain = {val for val in self.domains[var]
                       if const.holds({var:val})}
    elif len(other_vars)==1:        # binary constraint
        other = other_vars[0]
        new_domain = {val for val in self.domains[var]
                       if any(const.holds({var: val,other:other_val})
                               for other_val in self.domains[other])}
    else:                           # general case
        new_domain = {val for val in self.domains[var]
                       if self.any_holds(self.domains, const, {var: val}, other_vars)}

```

*any\_holds* is a recursive function that tries to find an assignment of values to the other variables (*other\_vars*) that satisfies constraint *const* given the assignment in *env*. The integer variable *ind* specifies which index to *other\_vars* needs to be

checked next. As soon as one assignment returns *True*, the algorithm returns *True*.

```

cspConsistency.py — (continued)
73 def any_holds(self, domains, const, env, other_vars, ind=0):
74     """returns True if Constraint const holds for an assignment
75     that extends env with the variables in other_vars[ind:]
76     env is a dictionary
77     """
78     if ind == len(other_vars):
79         return const.holds(env)
80     else:
81         var = other_vars[ind]
82         for val in domains[var]:
83             if self.any_holds(domains, const, env|{var:val}, other_vars,
84                             ind + 1):
85                 return True
86     return False

```

#### 4.4.1 Direct Implementation of Domain Splitting

The following is a direct implementation of domain splitting with arc consistency. It implements the generator interface of Python (see Section 1.5.4). When it has found a solution it yields the result; otherwise it recursively splits a domain (using `yield` from).

```

cspConsistency.py — (continued)
87 def generate_sols(self, domains=None, to_do=None, context=dict()):
88     """return list of all solution to the current CSP
89     to_do is the list of arcs to check
90     context is a dictionary of splits made (used for display)
91     """
92     new_domains = self.make_arc_consistent(domains, to_do)
93     if any(len(new_domains[var]) == 0 for var in new_domains):
94         self.display(1, f"No solutions for context {context}")
95     elif all(len(new_domains[var]) == 1 for var in new_domains):
96         self.display(1, "solution:", str({var: select(
97             new_domains[var]) for var in new_domains}))
98         yield {var: select(new_domains[var]) for var in new_domains}
99     else:
100        var = self.select_var(x for x in self.csp.variables if
101                             len(new_domains[x]) > 1)
102        dom1, dom2 = partition_domain(new_domains[var])
103        self.display(5, "...splitting", var, "into", dom1, "and", dom2)
104        new_doms1 = new_domains | {var:dom1}
105        new_doms2 = new_domains | {var:dom2}
106        to_do = self.new_to_do(var, None)
107        self.display(4, " adding", to_do if to_do else "nothing", "to
108        to_do.")

```

```

107         yield from self.generate_sols(new_doms1, to_do,
108                                     context|{var:dom1})
109         yield from self.generate_sols(new_doms2, to_do,
110                                     context|{var:dom1})
111
112     def solve_all(self, domains=None, to_do=None):
113         return list(self.generate_sols())
114
115     def solve_one(self, domains=None, to_do=None):
116         return select(self.generate_sols())
117
118     def select_var(self, iter_vars):
119         """return the next variable to split"""
120         return select(iter_vars)
121
122     def partition_domain(dom):
123         """partitions domain dom into two.
124         """
125         split = len(dom) // 2
126         dom1 = set(list(dom)[:split])
127         dom2 = dom - dom1
128         return dom1, dom2

```

---

cspConsistency.py — (continued)

---

```

128     def select(iterable):
129         """select an element of iterable. Returns None if there is no such
130             element.
131
132             This implementation just picks the first element.
133             For many of the uses, which element is selected does not affect
134             correctness,
135             but may affect efficiency.
136         """
137         for e in iterable:
138             return e # returns first element found

```

**Exercise 4.10** Implement *solve\_all* that returns the set of all solutions without using yield. Hint: it can be like *generate\_sols* but returns a set of solutions; the recursive calls can be unioned; | is Python’s union.

**Exercise 4.11** Implement *solve\_one* that returns one solution if one exists, or False otherwise, without using yield. Hint: Python’s “or” has the behaviour A or B will return the value of A unless it is None or False, in which case the value of B is returned.

Unit test:

---

cspConsistency.py — (continued)

---

```

138 import cspExamples
139 def ac_solver(csp):
140     "arc consistency (ac_solver)"

```

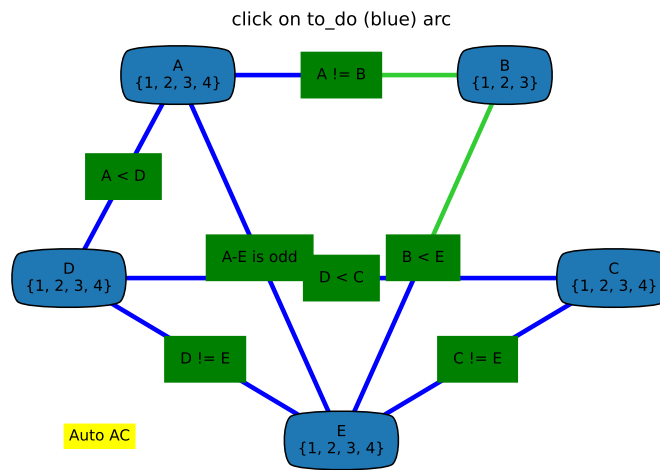

Figure 4.8: ConsistencyGUI(cspExamples.csp3).go()

```

141 |     for sol in Con_solver(csp).generate_sols():
142 |         return sol
143 |
144 | if __name__ == "__main__":
145 |     cspExamples.test_csp(ac_solver)

```

#### 4.4.2 Consistency GUI

The consistency GUI allows students to step through the algorithm, choosing which arc to process next, and which variable to split.

Figure 4.8 shows the state of the GUI after two arcs have been made arc consistent. The arcs on the to\_do list are colored blue. The green arcs are those that have been made arc consistent. The user can click on a blue arc to process that arc. If the arc selected is not arc consistent, it is made red, the domain is reduced, and then the arc becomes green. If the arc was already arc consistent it turns green.

This is implemented by overriding `select_arc` and `select_var` to allow the user to pick the arcs and the variables, and overriding `display` to allow for the animation. Note that the first argument of `display` (the number) in the code above is interpreted with a special meaning by the GUI and should only be changed with care.

Clicking AutoAC automates arc selection until the network is arc consistent.

```

_____cspConsistencyGUI.py — GUI for consistency-based CSP solving_____
11 | from cspConsistency import Con_solver
12 | import matplotlib.pyplot as plt
13 |

```

```

14 class ConsistencyGUI(Con_solver):
15     def __init__(self, csp, fontsize=10, speed=1, **kwargs):
16         """
17         csp is the csp to show
18         fontsize is the size of the text
19         speed is the number of animations per second (controls delay_time)
20         1 (slow) and 4 (fast) seem like good values
21         """
22         self.fontsize = fontsize
23         self.delay_time = 1/speed
24         Con_solver.__init__(self, csp, **kwargs)
25         csp.show(showAutoAC = True)
26
27     def go(self):
28         res = self.solve_all()
29         self.csp.draw_graph(domains=self.domains,
30                             title="No more solutions. GUI finished. ",
31                             fontsize=self.fontsize)
32         return res
33
34     def select_arc(self, to_do):
35         while True:
36             self.csp.draw_graph(domains=self.domains, to_do=to_do,
37                                 title="click on to_do (blue) arc",
38                                 fontsize=self.fontsize)
39             while self.csp.picked == None and not self.csp.autoAC:
40                 plt.pause(0.01) # controls reaction time of GUI
41             if self.csp.autoAC:
42                 break
43             picked = self.csp.picked
44             self.csp.picked = None
45             if picked in to_do:
46                 to_do.remove(picked)
47                 print(f"{picked} picked")
48                 return picked
49             else:
50                 print(f"{picked} not in to_do")
51         if self.csp.autoAC:
52             self.csp.draw_graph(domains=self.domains, to_do=to_do,
53                                 title="Auto AC", fontsize=self.fontsize)
54             plt.pause(self.delay_time)
55             return to_do.pop()
56
57     def select_var(self, iter_vars):
58         vars = list(iter_vars)
59         while True:
60             self.csp.draw_graph(domains=self.domains,
61                                 title="Arc consistent. Click node to
62                                 split",
63                                 fontsize=self.fontsize)

```

```

62         while self.csp.picked == None:
63             plt.pause(0.01) # controls reaction time of GUI
64             picked = self.csp.picked
65             self.csp.picked = None
66             self.csp.autoAC = False
67             if picked in vars:
68                 #print("splitting",picked)
69                 return picked
70             else:
71                 print(picked,"not in",vars)
72
73     def display(self,n,*args,**nargs):
74         if n <= self.max_display_level: # default display
75             print(*args, **nargs)
76         if n==1: # solution found or no solutions"
77             self.csp.draw_graph(domains=self.domains, to_do=set(),
78                                 title=' '.join(args)+" : click any node or
79                                     arc to continue",
80                                     fontsize=self.fontsize)
81             self.csp.autoAC = False
82             while self.csp.picked == None and not self.csp.autoAC:
83                 plt.pause(0.01) # controls reaction time of GUI
84                 self.csp.picked = None
85             elif n==2: # backtracking
86                 plt.title("backtracking: click any node or arc to continue")
87                 self.csp.autoAC = False
88                 while self.csp.picked == None and not self.csp.autoAC:
89                     plt.pause(0.01)
90                     self.csp.picked = None
91             elif n==3: # inconsistent arc
92                 line = self.csp.thelines[self.arc_selected]
93                 line.set_color('red')
94                 line.set_linewidth(10)
95                 plt.pause(self.delay_time)
96                 line.set_color('limegreen')
97                 line.set_linewidth(self.csp.linewidth)
98             #elif n==4 and self.add_to_do: # adding to to_do
99             #    print("adding to to_do",self.add_to_do) ## highlight these arc
100
101 import cspExamples
102 # Try:
103 # ConsistencyGUI(cspExamples.csp1).go()
104 # ConsistencyGUI(cspExamples.csp3).go()
105 # ConsistencyGUI(cspExamples.csp3, speed=4, fontsize=15).go()

```

### 4.4.3 Domain Splitting as an interface to graph searching

An alternative implementation is to implement domain splitting in terms of the search abstraction of Chapter 3.

A node is a dictionary that maps the variables to their (pruned) domains..

```

cspConsistency.py — (continued)
147 from searchProblem import Arc, Search_problem
148
149 class Search_with_AC_from_CSP(Search_problem, Displayable):
150     """A search problem with arc consistency and domain splitting
151
152     A node is a CSP """
153     def __init__(self, csp):
154         self.cons = Con_solver(csp) #copy of the CSP
155         self.domains = self.cons.make_arc_consistent()
156
157     def is_goal(self, node):
158         """node is a goal if all domains have 1 element"""
159         return all(len(node[var])==1 for var in node)
160
161     def start_node(self):
162         return self.domains
163
164     def neighbors(self, node):
165         """returns the neighboring nodes of node.
166         """
167         neighs = []
168         var = select(x for x in node if len(node[x])>1)
169         if var:
170             dom1, dom2 = partition_domain(node[var])
171             self.display(2, "Splitting", var, "into", dom1, "and", dom2)
172             to_do = self.cons.new_to_do(var, None)
173             for dom in [dom1, dom2]:
174                 newdoms = node | {var: dom}
175                 cons_doms = self.cons.make_arc_consistent(newdoms, to_do)
176                 if all(len(cons_doms[v])>0 for v in cons_doms):
177                     # all domains are non-empty
178                     neighs.append(Arc(node, cons_doms))
179             else:
180                 self.display(2, "...", var, "in", dom, "has no solution")
181         return neighs

```

**Exercise 4.12** When splitting a domain, this code splits the domain into half, approximately in half (without any effort to make a sensible choice). Does it work better to split one element from a domain?

Unit test:

```

cspConsistency.py — (continued)
183 import cspExamples
184 from searchGeneric import Searcher
185
186 def ac_search_solver(csp):
187     """arc consistency (search interface)"""

```

```

188     sol = Searcher(Search_with_AC_from_CSP(csp)).search()
189     if sol:
190         return {v:select(d) for (v,d) in sol.end().items()}
191
192 if __name__ == "__main__":
193     cspExamples.test_csp(ac_search_solver)

```

Testing:

```

_____cspConsistency.py — (continued)_____
195 ## Test Solving CSPs with Arc consistency and domain splitting:
196 #Con_solver.max_display_level = 4 # display details of AC (0 turns off)
197 #Con_solver(cspExamples.csp1).solve_all()
198 #searcher1d = Searcher(Search_with_AC_from_CSP(cspExamples.csp1))
199 #print(searcher1d.search())
200 #Searcher.max_display_level = 2 # display search trace (0 turns off)
201 #searcher2c = Searcher(Search_with_AC_from_CSP(cspExamples.csp2))
202 #print(searcher2c.search())
203 #searcher3c = Searcher(Search_with_AC_from_CSP(cspExamples.crossword1))
204 #print(searcher3c.search())
205 #searcher4c = Searcher(Search_with_AC_from_CSP(cspExamples.crossword1d))
206 #print(searcher4c.search())

```

## 4.5 Solving CSPs using Stochastic Local Search

To run the demo, in folder "aipython", load "cspSLS.py", and copy and paste the commented-out example queries at the bottom of that file. This assumes Python 3. Some of the queries require matplotlib.

The following code implements the two-stage choice (select one of the variables that are involved in the most constraints that are violated, then a value), the any-conflict algorithm (select a variable that participates in a violated constraint) and a random choice of variable, as well as a probabilistic mix of the three.

Given a CSP, the stochastic local searcher (*SLSearcher*) creates the data structures:

- *variables\_to\_select* is the set of all of the variables with domain-size greater than one. For a variable not in this set, we cannot pick another value from that variable.
- *var\_to\_constraints* maps from a variable into the set of constraints it is involved in. Note that the inverse mapping from constraints into variables is part of the definition of a constraint.

```

_____cspSLS.py — Stochastic Local Search for Solving CSPs_____
11 from cspProblem import CSP, Constraint

```

```

12 from searchProblem import Arc, Search_problem
13 from display import Displayable
14 import random
15 import heapq
16
17 class SLSearcher(Displayable):
18     """A search problem directly from the CSP..
19
20     A node is a variable:value dictionary"""
21     def __init__(self, csp):
22         self.csp = csp
23         self.variables_to_select = {var for var in self.csp.variables
24                                     if len(var.domain) > 1}
25         # Create assignment and conflicts set
26         self.current_assignment = None # this will trigger a random restart
27         self.number_of_steps = 0 #number of steps after the initialization

```

*restart* creates a new total assignment, and constructs the set of conflicts (the constraints that are false in this assignment).

---

cspSLS.py — (continued) —

```

29     def restart(self):
30         """creates a new total assignment and the conflict set
31         """
32         self.current_assignment = {var:random_choice(var.domain) for
33                                     var in self.csp.variables}
34         self.display(2,"Initial assignment",self.current_assignment)
35         self.conflicts = set()
36         for con in self.csp.constraints:
37             if not con.holds(self.current_assignment):
38                 self.conflicts.add(con)
39         self.display(2,"Number of conflicts",len(self.conflicts))
40         self.variable_pq = None

```

The *search* method is the top-level searching algorithm. It can either be used to start the search or to continue searching. If there is no current assignment, it must create one. Note that, when counting steps, a restart is counted as one step, which is not appropriate for CSPs with many variables, as it is a relatively expensive operation for these cases.

This method selects one of two implementations. The argument *prob\_best* is the probability of selecting a best variable (one involving the most conflicts). When the value of *prob\_best* is positive, the algorithm needs to maintain a priority queue of variables and the number of conflicts (using *search\_with\_var\_pq*). If the probability of selecting a best variable is zero, it does not need to maintain this priority queue (as implemented in *search\_with\_any\_conflict*).

The argument *prob\_anycon* is the probability that the any-conflict strategy is used (which selects a variable at random that is in a conflict), assuming that it is not picking a best variable. Note that for the probability parameters, any value less than zero acts like probability zero and any value greater than 1 acts

like probability 1. This means that when  $prob\_anycon = 1.0$ , a best variable is chosen with probability  $prob\_best$ , otherwise a variable in any conflict is chosen. A variable is chosen at random with probability  $1 - prob\_anycon - prob\_best$  as long as that is positive.

This returns the number of steps needed to find a solution, or *None* if no solution is found. If there is a solution, it is in *self.current\_assignment*.

```

cspSLS.py — (continued)
42 | def search(self,max_steps, prob_best=0, prob_anycon=1.0):
43 |     """
44 |     returns the number of steps or None if these is no solution.
45 |     If there is a solution, it can be found in self.current_assignment
46 |
47 |     max_steps is the maximum number of steps it will try before giving
48 |     up
49 |     prob_best is the probability that a best variable (one in most
50 |     conflict) is selected
51 |     prob_anycon is the probability that a variable in any conflict is
52 |     selected
53 |     (otherwise a variable is chosen at random)
54 |     """
55 |     if self.current_assignment is None:
56 |         self.restart()
57 |         self.number_of_steps += 1
58 |         if not self.conflicts:
59 |             self.display(1,"Solution found:", self.current_assignment,
60 |                         "after restart")
61 |             return self.number_of_steps
62 |     if prob_best > 0: # we need to maintain a variable priority queue
63 |         return self.search_with_var_pq(max_steps, prob_best,
64 |                                         prob_anycon)
65 |     else:
66 |         return self.search_with_any_conflict(max_steps, prob_anycon)

```

**Exercise 4.13** This does an initial random assignment but does not do any random restarts. Implement a searcher that takes in the maximum number of walk steps (corresponding to existing *max\_steps*) and the maximum number of restarts, and returns the total number of steps for the first solution found. (As in *search*, the solution found can be extracted from the variable *self.current\_assignment*).

### 4.5.1 Any-conflict

In the any-conflict heuristic a variable that participates in a violated constraint is picked at random. The implementation need to keeps track of which variables are in conflicts. This is can avoid the need for a priority queue that is needed when the probability of picking a best variable is greter than zero.

```

cspSLS.py — (continued)
63 | def search_with_any_conflict(self, max_steps, prob_anycon=1.0):

```

```

64     """Searches with the any_conflict heuristic.
65     This relies on just maintaining the set of conflicts;
66     it does not maintain a priority queue
67     """
68     self.variable_pq = None # we are not maintaining the priority queue.
69                             # This ensures it is regenerated if
70                             # we call search_with_var_pq.
71     for i in range(max_steps):
72         self.number_of_steps +=1
73         if random.random() < probab_anycon:
74             con = random_choice(self.conflicts) # pick random conflict
75             var = random_choice(con.scope) # pick variable in conflict
76         else:
77             var = random_choice(self.variables_to_select)
78         if len(var.domain) > 1:
79             val = random_choice([val for val in var.domain
80                                 if val is not
81                                 self.current_assignment[var]])
82             self.display(2,self.number_of_steps,":
83             Assigning",var,"=",val)
84             self.current_assignment[var]=val
85             for varcon in self.csp.var_to_const[var]:
86                 if varcon.holds(self.current_assignment):
87                     if varcon in self.conflicts:
88                         self.conflicts.remove(varcon)
89                     else:
90                         if varcon not in self.conflicts:
91                             self.conflicts.add(varcon)
92             self.display(2,"  Number of conflicts",len(self.conflicts))
93         if not self.conflicts:
94             self.display(1,"Solution found:", self.current_assignment,
95                         "in", self.number_of_steps,"steps")
96             return self.number_of_steps
97         self.display(1,"No solution in",self.number_of_steps,"steps",
98                     len(self.conflicts),"conflicts remain")
99     return None

```

**Exercise 4.14** This makes no attempt to find the best value for the variable selected. Modify the code to include an option selects a value for the selected variable that reduces the number of conflicts the most. Have a parameter that specifies the probability that the best value is chosen, and otherwise chooses a value at random.

### 4.5.2 Two-Stage Choice

This is the top-level searching algorithm that maintains a priority queue of variables ordered by the number of conflicts, so that the variable with the most conflicts is selected first. If there is no current priority queue of variables, one is created.

The main complexity here is to maintain the priority queue. When a variable `var` is assigned a value `val`, for each constraint that has become satisfied or unsatisfied, each variable involved in the constraint need to have its count updated. The change is recorded in the dictionary `var_differential`, which is used to update the priority queue (see Section 4.5.3).

```

cspSLS.py — (continued)
99     def search_with_var_pq(self,max_steps, prob_best=1.0, prob_anycon=1.0):
100         """search with a priority queue of variables.
101         This is used to select a variable with the most conflicts.
102         """
103         if not self.variable_pq:
104             self.create_pq()
105         pick_best_or_con = prob_best + prob_anycon
106         for i in range(max_steps):
107             self.number_of_steps +=1
108             randnum = random.random()
109             ## Pick a variable
110             if randnum < prob_best: # pick best variable
111                 var,oldval = self.variable_pq.top()
112             elif randnum < pick_best_or_con: # pick a variable in a conflict
113                 con = random_choice(self.conflicts)
114                 var = random_choice(con.scope)
115             else: #pick any variable that can be selected
116                 var = random_choice(self.variables_to_select)
117             if len(var.domain) > 1: # var has other values
118                 ## Pick a value
119                 val = random_choice([val for val in var.domain if val is not
120                                     self.current_assignment[var]])
121                 self.display(2,"Assigning",var,val)
122                 ## Update the priority queue
123                 var_differential = {}
124                 self.current_assignment[var]=val
125                 for varcon in self.csp.var_to_const[var]:
126                     self.display(3,"Checking",varcon)
127                     if varcon.holds(self.current_assignment):
128                         if varcon in self.conflicts: #was incons, now consis
129                             self.display(3,"Became consistent",varcon)
130                             self.conflicts.remove(varcon)
131                             for v in varcon.scope: # v is in one fewer
132                                 conflicts
133                                     var_differential[v] =
134                                         var_differential.get(v,0)-1
135                             else:
136                                 if varcon not in self.conflicts: # was consis, not now
137                                     self.display(3,"Became inconsistent",varcon)
138                                     self.conflicts.add(varcon)
139                                     for v in varcon.scope: # v is in one more
140                                         conflicts
141                                             var_differential[v] =

```

```

139         var_differential.get(v,0)+1
140         self.variable_pq.update_each_priority(var_differential)
141         self.display(2,"Number of conflicts",len(self.conflicts))
142         if not self.conflicts: # no conflicts, so solution found
143             self.display(1,"Solution found:",
144                 self.current_assignment,"in",
145                 self.number_of_steps,"steps")
146             return self.number_of_steps
147         self.display(1,"No solution in",self.number_of_steps,"steps",
148             len(self.conflicts),"conflicts remain")
149         return None

```

`create_pq` creates an updatable priority queue of the variables, ordered by the number of conflicts they participate in. The priority queue only includes variables in conflicts and the value of a variable is the *negative* of the number of conflicts the variable is in. This ensures that the priority queue, which picks the minimum value, picks a variable with the most conflicts.

cspSLS.py — (continued)

```

149 def create_pq(self):
150     """Create the variable to number-of-conflicts priority queue.
151     This is needed to select the variable in the most conflicts.
152
153     The value of a variable in the priority queue is the negative of the
154     number of conflicts the variable appears in.
155     """
156     self.variable_pq = Updatable_priority_queue()
157     var_to_number_conflicts = {}
158     for con in self.conflicts:
159         for var in con.scope:
160             var_to_number_conflicts[var] =
161                 var_to_number_conflicts.get(var,0)+1
162     for var,num in var_to_number_conflicts.items():
163         if num>0:
164             self.variable_pq.add(var,-num)

```

cspSLS.py — (continued)

```

165 def random_choice(st):
166     """selects a random element from set st.
167     It would be more efficient to convert to a tuple or list only once
168     (left as exercise)."""
169     return random.choice(tuple(st))

```

**Exercise 4.15** These implementations always select a value for the variable selected that is different from its current value (if that is possible). Change the code so that it does not have this restriction (so it can leave the value the same). Would you expect this code to be faster? Does it work worse (or better)?

### 4.5.3 Updatable Priority Queues

An **updatable priority queue** is a priority queue, where key-value pairs can be stored, and the pair with the smallest key can be found and removed quickly, and where the values can be updated. This implementation follows the idea of <http://docs.python.org/3.9/library/heapq.html>, where the updated elements are marked as removed. This means that the priority queue can be used unmodified. However, this might be expensive if changes are more common than popping (as might happen if the probability of choosing the best is close to zero).

In this implementation, the equal values are sorted randomly. This is achieved by having the elements of the heap being  $[val, rand, elt]$  triples, where the second element is a random number. Note that Python requires this to be a list, not a tuple, as the tuple cannot be modified.

cspSLS.py — (continued)

```

171 class Updatable_priority_queue(object):
172     """A priority queue where the values can be updated.
173     Elements with the same value are ordered randomly.
174
175     This code is based on the ideas described in
176     http://docs.python.org/3.3/library/heapq.html
177     It could probably be done more efficiently by
178     shuffling the modified element in the heap.
179     """
180     def __init__(self):
181         self.pq = [] # priority queue of [val,rand,elt] triples
182         self.elt_map = {} # map from elt to [val,rand,elt] triple in pq
183         self.REMOVED = "*removed*" # a string that won't be a legal element
184         self.max_size=0
185
186     def add(self,elt,val):
187         """adds elt to the priority queue with priority=val.
188         """
189         assert val <= 0,val
190         assert elt not in self.elt_map, elt
191         new_triple = [val, random.random(),elt]
192         heapq.heappush(self.pq, new_triple)
193         self.elt_map[elt] = new_triple
194
195     def remove(self,elt):
196         """remove the element from the priority queue"""
197         if elt in self.elt_map:
198             self.elt_map[elt][2] = self.REMOVED
199             del self.elt_map[elt]
200
201     def update_each_priority(self,update_dict):
202         """update values in the priority queue by subtracting the values in
203         update_dict from the priority of those elements in priority queue.

```

```

204     """
205     for elt,incr in update_dict.items():
206         if incr != 0:
207             newval = self.elt_map.get(elt,[0])[0] - incr
208             assert newval <= 0, f"{elt}:{newval+incr}-{incr}"
209             self.remove(elt)
210             if newval != 0:
211                 self.add(elt,newval)
212
213     def pop(self):
214         """Removes and returns the (elt,value) pair with minimal value.
215         If the priority queue is empty, IndexError is raised.
216         """
217         self.max_size = max(self.max_size, len(self.pq)) # keep statistics
218         triple = heapq.heappop(self.pq)
219         while triple[2] == self.REMOVED:
220             triple = heapq.heappop(self.pq)
221         del self.elt_map[triple[2]]
222         return triple[2], triple[0] # elt, value
223
224     def top(self):
225         """Returns the (elt,value) pair with minimal value, without
226         removing it.
227         If the priority queue is empty, IndexError is raised.
228         """
229         self.max_size = max(self.max_size, len(self.pq)) # keep statistics
230         triple = self.pq[0]
231         while triple[2] == self.REMOVED:
232             heapq.heappop(self.pq)
233             triple = self.pq[0]
234         return triple[2], triple[0] # elt, value
235
236     def empty(self):
237         """returns True iff the priority queue is empty"""
238         return all(triple[2] == self.REMOVED for triple in self.pq)

```

#### 4.5.4 Plotting Run-Time Distributions

*Runtime.distribution* uses matplotlib to plot run time distributions. Here the run time is a misnomer as we are only plotting the number of steps, not the time. Computing the run time is non-trivial as many of the runs have a very short run time. To compute the time accurately would require running the same code, with the same random seed, multiple times to get a good estimate of the run time. This is left as an exercise.

---

cspSLS.py — (continued)

---

```

239 import matplotlib.pyplot as plt
240 # plt.style.use('grayscale')
241

```

```

242 class Runtime_distribution(object):
243     def __init__(self, csp, xscale='log'):
244         """Sets up plotting for csp
245         xscale is either 'linear' or 'log'
246         """
247         self.csp = csp
248         plt.ion()
249         plt.xlabel("Number of Steps")
250         plt.ylabel("Cumulative Number of Runs")
251         plt.xscale(xscale) # Makes a 'log' or 'linear' scale
252
253     def plot_runs(self,num_runs=100,max_steps=1000, prob_best=1.0,
254                 prob_anycon=1.0):
255         """Plots num_runs of SLS for the given settings.
256         """
257         stats = []
258         SLSearcher.max_display_level, temp_mdl = 0,
259             SLSearcher.max_display_level # no display
260         for i in range(num_runs):
261             searcher = SLSearcher(self.csp)
262             num_steps = searcher.search(max_steps, prob_best, prob_anycon)
263             if num_steps:
264                 stats.append(num_steps)
265             stats.sort()
266             if prob_best >= 1.0:
267                 label = "P(best)=1.0"
268             else:
269                 p_ac = min(prob_anycon, 1-prob_best)
270                 label = "P(best)=%.2f, P(ac)=%.2f" % (prob_best, p_ac)
271             plt.plot(stats,range(len(stats)),label=label)
272             plt.legend(loc="upper left")
273             SLSearcher.max_display_level= temp_mdl #restore display

```

Figure 4.9 gives run-time distributions for 3 algorithms. It is also useful to compare the distributions of different runs of the same algorithms and settings.

### 4.5.5 Testing

```

_____cspSLS.py — (continued)_____
273 import cspExamples
274 def sls_solver(csp,prob_best=0.7):
275     """stochastic local searcher (prob_best=0.7)"""
276     se0 = SLSearcher(csp)
277     se0.search(1000,prob_best)
278     return se0.current_assignment
279 def any_conflict_solver(csp):
280     """stochastic local searcher (any-conflict)"""
281     return sls_solver(csp,0)
282

```

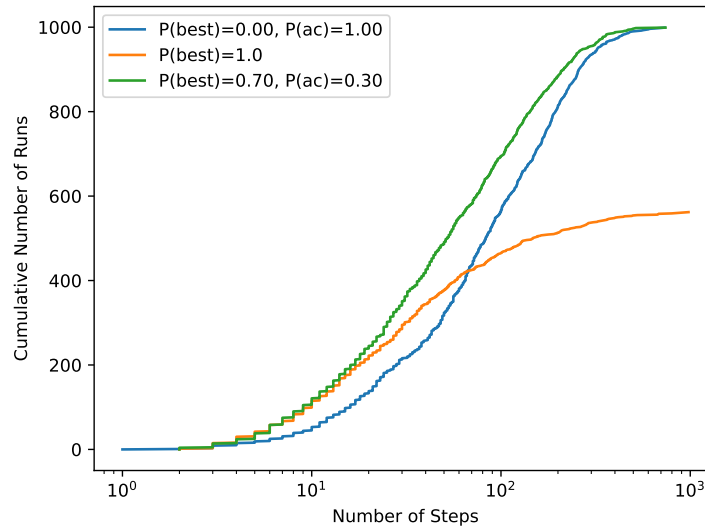

Figure 4.9: Run-time distributions for three algorithms on *csp2*.

```

283 if __name__ == "__main__":
284     cspExamples.test_csp(sls_solver)
285     cspExamples.test_csp(any_conflict_solver)
286
287 ## Test Solving CSPs with Search:
288 #se1 = SLSearcher(cspExamples.csp1); print(se1.search(100))
289 #se2 = SLSearcher(cspExamples.csp2); print(se2.search(1000,1.0)) # greedy
290 #se2 = SLSearcher(cspExamples.csp2); print(se2.search(1000,0)) #
    any_conflict
291 #se2 = SLSearcher(cspExamples.csp2); print(se2.search(1000,0.7)) # 70%
    greedy; 30% any_conflict
292 #SLSearcher.max_display_level=2 #more detailed display
293 #se3 = SLSearcher(cspExamples.crossword1); print(se3.search(100),0.7)
294 #p = Runtime_distribution(cspExamples.csp2)
295 #p.plot_runs(1000,1000,0) # any_conflict
296 #p.plot_runs(1000,1000,1.0) # greedy
297 #p.plot_runs(1000,1000,0.7) # 70% greedy; 30% any_conflict

```

**Exercise 4.16** Modify this to plot the run time, instead of the number of steps. To measure run time use *timeit* (<https://docs.python.org/3.9/library/timeit.html>). Small run times are inaccurate, so *timeit* can run the same code multiple times. Stochastic local algorithms give different run times each time called. To make the timing meaningful, you need to make sure the random seed is the same for each repeated call (see *random.getstate* and *random.setstate* in <https://docs.python.org/3.9/library/random.html>). Because the run time for different seeds can vary a great deal, for each seed, you should start with 1 iteration and multiplying it by, say 10, until the time is greater than 0.2 seconds. Make sure you

plot the average time for each run. Before you start, try to estimate the total run time, so you will be able to tell if there is a problem with the algorithm stopping.

## 4.6 Discrete Optimization

A `SoftConstraint` is a constraint, but where the condition is a real-valued function. Because the definition of the constraint class did not force the condition to be Boolean, you can use the `Constraint` class for soft constraints too.

```

_____cspSoft.py — Representations of Soft Constraints_____
11 from cspProblem import Variable, Constraint, CSP
12 class SoftConstraint(Constraint):
13     """A Constraint consists of
14     * scope: a tuple of variables
15     * function: a real-valued function that can applied to a tuple of values
16     * string: a string for printing the constraints. All of the strings
17       must be unique.
18     for the variables
19     """
19     def __init__(self, scope, function, string=None, position=None):
20         Constraint.__init__(self, scope, function, string, position)
21
22     def value(self, assignment):
23         return self.holds(assignment)
_____cspSoft.py — (continued)_____
25 A = Variable('A', {1,2}, position=(0.2,0.9))
26 B = Variable('B', {1,2,3}, position=(0.8,0.9))
27 C = Variable('C', {1,2}, position=(0.5,0.5))
28 D = Variable('D', {1,2}, position=(0.8,0.1))
29
30 def c1fun(a,b):
31     if a==1: return (5 if b==1 else 2)
32     else: return (0 if b==1 else 4 if b==2 else 3)
33 c1 = SoftConstraint([A,B],c1fun,"c1")
34 def c2fun(b,c):
35     if b==1: return (5 if c==1 else 2)
36     elif b==2: return (0 if c==1 else 4)
37     else: return (2 if c==1 else 0)
38 c2 = SoftConstraint([B,C],c2fun,"c2")
39 def c3fun(b,d):
40     if b==1: return (3 if d==1 else 0)
41     elif b==2: return 2
42     else: return (2 if d==1 else 4)
43 c3 = SoftConstraint([B,D],c3fun,"c3")
44
45 def penalty_if_same(pen):
46     "returns a function that gives a penalty of pen if the arguments are
47     the same"

```

```

47     return lambda x,y: (pen if (x==y) else 0)
48
49 c4 = SoftConstraint([C,A],penalty_if_same(3),"c4")
50
51 scsp1 = CSP("scsp1", {A,B,C,D}, [c1,c2,c3,c4])
52
53 ### The second soft CSP has an extra variable, and 2 constraints
54 E = Variable('E', {1,2}, position=(0.1,0.1))
55
56 c5 = SoftConstraint([C,E],penalty_if_same(3),"c5")
57 c6 = SoftConstraint([D,E],penalty_if_same(2),"c6")
58 scsp2 = CSP("scsp1", {A,B,C,D,E}, [c1,c2,c3,c4,c5,c6])

```

### 4.6.1 Branch-and-bound Search

Here we specialize the branch-and-bound algorithm (Section 3.3 on page 64) to solve soft CSP problems.

```

_____cspSoft.py — (continued)_____
60 from display import Displayable, visualize
61 import math
62
63 class DF_branch_and_bound_opt(Displayable):
64     """returns a branch and bound searcher for a problem.
65     An optimal assignment with cost less than bound can be found by calling
66     search()
67     """
68     def __init__(self, csp, bound=math.inf):
69         """creates a searcher than can be used with search() to find an
70         optimal path.
71         bound gives the initial bound. By default this is infinite -
72         meaning there
73         is no initial pruning due to depth bound
74         """
75         super().__init__()
76         self.csp = csp
77         self.best_asst = None
78         self.bound = bound
79
80     def optimize(self):
81         """returns an optimal solution to a problem with cost less than
82         bound.
83         returns None if there is no solution with cost less than bound."""
84         self.num_expanded=0
85         self.cbsearch({}, 0, self.csp.constraints)
86         self.display(1,"Number of paths expanded:",self.num_expanded)
87         return self.best_asst, self.bound
88
89     def cbsearch(self, asst, cost, constraints):

```

```

86     """finds the optimal solution that extends path and is less the
87         bound"""
88     self.display(2,"cbsearch:",asst,cost,constraints)
89     can_eval = [c for c in constraints if c.can_evaluate(asst)]
90     rem_cons = [c for c in constraints if c not in can_eval]
91     newcost = cost + sum(c.value(asst) for c in can_eval)
92     self.display(2,"Evaluating:",can_eval,"cost:",newcost)
93     if newcost < self.bound:
94         self.num_expanded += 1
95         if rem_cons==[]:
96             self.best_asst = asst
97             self.bound = newcost
98             self.display(1,"New best assignment:",asst," cost:",newcost)
99         else:
100            var = next(var for var in self.csp.variables if var not in
101                       asst)
102            for val in var.domain:
103                self.cbsearch({var:val}|asst, newcost, rem_cons)
104
105 # bnb = DF_branch_and_bound_opt(scsp1)
106 # bnb.max_display_level=3 # show more detail
107 # bnb.optimize()

```

**Exercise 4.17** Change the stochastic-local search algorithms to work for soft constraints. Hint: The analog of a conflict is a soft constraint that is not at its lowest value. Instead of the number of constraints violated, consider how much a change in a variable affects the objective function. Instead of returning a solution, return the best assignment found.



## Propositions and Inference

### 5.1 Representing Knowledge Bases

A clause consists of a head (an atom) and a body. A body is represented as a list of atoms. Atoms are represented as strings.

```
_____logicProblem.py — Representations Logics _____  
11 class Clause(object):  
12     """A definite clause"""  
13  
14     def __init__(self, head, body=[]):  
15         """clause with atom head and list of atoms body"""  
16         self.head=head  
17         self.body = body  
18  
19     def __repr__(self):  
20         """returns the string representation of a clause.  
21         """  
22         if self.body:  
23             return f"{self.head} <- {' & '.join(str(a) for a in  
24                 self.body)}."  
25         else:  
26             return f"{self.head}."
```

An askable atom can be asked of the user. The user can respond in English or French or just with a "y".

```
_____logicProblem.py — (continued) _____  
27 class Askable(object):  
28     """An askable atom"""  
29  
30     def __init__(self, atom):
```

```

31     """clause with atom head and list of atoms body"""
32     self.atom=atom
33
34     def __str__(self):
35         """returns the string representation of a clause."""
36         return "askable " + self.atom + "."
37
38     def yes(ans):
39         """returns true if the answer is yes in some form"""
40         return ans.lower() in ['yes', 'oui', 'y'] # bilingual

```

A knowledge base is a list of clauses and askables. In order to make top-down inference faster, this creates a dictionary that maps each atom into the set of clauses with that atom in the head.

---

```

                                     logicProblem.py — (continued)
42 from display import Displayable
43
44 class KB(Displayable):
45     """A knowledge base consists of a set of clauses.
46     This also creates a dictionary to give fast access to the clauses with
47     an atom in head.
48     """
49     def __init__(self, statements=[]):
50         self.statements = statements
51         self.clauses = [c for c in statements if isinstance(c, Clause)]
52         self.askables = [c.atom for c in statements if isinstance(c,
53                             Askable)]
54         self.atom_to_clauses = {} # dictionary giving clauses with atom as
55                                 head
56         for c in self.clauses:
57             self.add_clause(c)
58
59     def add_clause(self, c):
60         if c.head in self.atom_to_clauses:
61             self.atom_to_clauses[c.head].append(c)
62         else:
63             self.atom_to_clauses[c.head] = [c]
64
65     def clauses_for_atom(self, a):
66         """returns list of clauses with atom a as the head"""
67         if a in self.atom_to_clauses:
68             return self.atom_to_clauses[a]
69         else:
70             return []
71
72     def __str__(self):
73         """returns a string representation of this knowledge base.
74         """
75         return '\n'.join([str(c) for c in self.statements])

```

Here is a trivial example (I think therefore I am) used in the unit tests:

```

_____ logicProblem.py — (continued) _____
74 triv_KB = KB([
75     Clause('i_am', ['i_think']),
76     Clause('i_think'),
77     Clause('i_smell', ['i_exist'])
78 ])

```

Here is a representation of the electrical domain of the textbook:

```

_____ logicProblem.py — (continued) _____
80 elect = KB([
81     Clause('light_l1'),
82     Clause('light_l2'),
83     Clause('ok_l1'),
84     Clause('ok_l2'),
85     Clause('ok_cb1'),
86     Clause('ok_cb2'),
87     Clause('live_outside'),
88     Clause('live_l1', ['live_w0']),
89     Clause('live_w0', ['up_s2', 'live_w1']),
90     Clause('live_w0', ['down_s2', 'live_w2']),
91     Clause('live_w1', ['up_s1', 'live_w3']),
92     Clause('live_w2', ['down_s1', 'live_w3']),
93     Clause('live_l2', ['live_w4']),
94     Clause('live_w4', ['up_s3', 'live_w3']),
95     Clause('live_p1', ['live_w3']),
96     Clause('live_w3', ['live_w5', 'ok_cb1']),
97     Clause('live_p2', ['live_w6']),
98     Clause('live_w6', ['live_w5', 'ok_cb2']),
99     Clause('live_w5', ['live_outside']),
100    Clause('lit_l1', ['light_l1', 'live_l1', 'ok_l1']),
101    Clause('lit_l2', ['light_l2', 'live_l2', 'ok_l2']),
102    Askable('up_s1'),
103    Askable('down_s1'),
104    Askable('up_s2'),
105    Askable('down_s2'),
106    Askable('up_s3'),
107    Askable('down_s2')
108 ])
109
110 # print(kb)

```

The following knowledge base is false in the intended interpretation. One of the clauses is wrong; can you see which one? We will show how to debug it.

```

_____ logicProblem.py — (continued) _____
111 elect_bug = KB([
112     Clause('light_l2'),
113     Clause('ok_l1'),
114     Clause('ok_l2'),

```

```

115     Clause('ok_cb1'),
116     Clause('ok_cb2'),
117     Clause('live_outside'),
118     Clause('live_p_2', ['live_w6']),
119     Clause('live_w6', ['live_w5', 'ok_cb2']),
120     Clause('light_l1'),
121     Clause('live_w5', ['live_outside']),
122     Clause('lit_l1', ['light_l1', 'live_l1', 'ok_l1']),
123     Clause('lit_l2', ['light_l2', 'live_l2', 'ok_l2']),
124     Clause('live_l1', ['live_w0']),
125     Clause('live_w0', ['up_s2', 'live_w1']),
126     Clause('live_w0', ['down_s2', 'live_w2']),
127     Clause('live_w1', ['up_s3', 'live_w3']),
128     Clause('live_w2', ['down_s1', 'live_w3' ]),
129     Clause('live_l2', ['live_w4']),
130     Clause('live_w4', ['up_s3', 'live_w3' ]),
131     Clause('live_p_1', ['live_w3']),
132     Clause('live_w3', ['live_w5', 'ok_cb1']),
133     Askable('up_s1'),
134     Askable('down_s1'),
135     Askable('up_s2'),
136     Clause('light_l2'),
137     Clause('ok_l1'),
138     Clause('light_l2'),
139     Clause('ok_l1'),
140     Clause('ok_l2'),
141     Clause('ok_cb1'),
142     Clause('ok_cb2'),
143     Clause('live_outside'),
144     Clause('live_p_2', ['live_w6']),
145     Clause('live_w6', ['live_w5', 'ok_cb2']),
146     Clause('ok_l2'),
147     Clause('ok_cb1'),
148     Clause('ok_cb2'),
149     Clause('live_outside'),
150     Clause('live_p_2', ['live_w6']),
151     Clause('live_w6', ['live_w5', 'ok_cb2']),
152     Askable('down_s2'),
153     Askable('up_s3'),
154     Askable('down_s2')
155 ]
156
157 # print(kb)

```

## 5.2 Bottom-up Proofs (with askables)

*fixed\_point* computes the fixed point of the knowledge base *kb*.

---

logicBottomUp.py — Bottom-up Proof Procedure for Definite Clauses

```

11 from logicProblem import yes
12
13 def fixed_point(kb):
14     """Returns the fixed point of knowledge base kb.
15     """
16     fp = ask_askables(kb)
17     added = True
18     while added:
19         added = False # added is true when an atom was added to fp this
20             iteration
21         for c in kb.clauses:
22             if c.head not in fp and all(b in fp for b in c.body):
23                 fp.add(c.head)
24                 added = True
25                 kb.display(2,c.head,"added to fp due to clause",c)
26
27     return fp
28
29 def ask_askables(kb):
30     return {at for at in kb.askables if yes(input("Is "+at+" true? "))}

```

The following provides a trivial **unit test**, by default using the knowledge base `triv_KB`:

---

```

_____logicBottomUp.py — (continued)_____
30 from logicProblem import triv_KB
31 def test(kb=triv_KB, fixedpt = {'i_am','i_think'}):
32     fp = fixed_point(kb)
33     assert fp == fixedpt, f"kb gave result {fp}"
34     print("Passed unit test")
35 if __name__ == "__main__":
36     test()
37
38 from logicProblem import elect
39 # elect.max_display_level=3 # give detailed trace
40 # fixed_point(elect)

```

**Exercise 5.1** It is not very user-friendly to ask all of the askables up-front. Implement `ask-the-user` so that questions are only asked if useful, and are not re-asked. For example, if there is a clause  $h \leftarrow a \wedge b \wedge c \wedge d \wedge e$ , where  $c$  and  $e$  are askable,  $c$  and  $e$  only need to be asked if  $a, b, d$  are all in  $fp$  and they have not been asked before. Askable  $e$  only needs to be asked if the user says “yes” to  $c$ . Askable  $c$  doesn’t need to be asked if the user previously replied “no” to  $e$ .

This form of `ask-the-user` can ask a different set of questions than the top-down interpreter that asks questions when encountered. Give an example where they ask different questions (neither set of questions asked is a subset of the other).

**Exercise 5.2** This algorithm runs in time  $O(n^2)$ , where  $n$  is the number of clauses, for a bounded number of elements in the body; each iteration goes through each of the clauses, and in the worst case, it will do an iteration for each clause. It is possible to implement this in time  $O(n)$  time by creating an index that maps an atom to the set of clauses with that atom in the body. Implement this. What is its

complexity as a function of  $n$  and  $b$ , the maximum number of atoms in the body of a clause?

**Exercise 5.3** It is possible to be asymptotically more efficient (in terms of the number of elements in a body) than the method in the previous question by noticing that each element of the body of clause only needs to be checked once. For example, the clause  $a \leftarrow b \wedge c \wedge d$ , needs only be considered when  $b$  is added to  $fp$ . Once  $b$  is added to  $fp$ , if  $c$  is already in  $fp$ , we know that  $a$  can be added as soon as  $d$  is added. Implement this. What is its complexity as a function of  $n$  and  $b$ , the maximum number of atoms in the body of a clause?

### 5.3 Top-down Proofs (with askables)

The following implements the top-down proof procedure for propositional definite clauses, as described in Section 5.3.2 and Figure 5.4 of Poole and Mackworth [2023]. It implements “choose” by looping over the alternatives (using Python’s `any`) and returning true if any choice leads to a proof.

`prove(kb, goal)` is used to prove `goal` from a knowledge base, `kb`, where a `goal` is a list of atoms. It returns `True` if  $kb \vdash goal$ . The `indent` is used when displaying the code (and doesn’t need to be called initially with a non-default value).

```

_____logicTopDown.py — Top-down Proof Procedure for Definite Clauses_____
11 from logicProblem import yes
12
13 def prove(kb, ans_body, indent=""):
14     """returns True if kb |- ans_body
15     ans_body is a list of atoms to be proved
16     """
17     kb.display(2,indent,'yes <-',' & '.join(ans_body))
18     if ans_body:
19         selected = ans_body[0] # select first atom from ans_body
20         if selected in kb.askables:
21             return (yes(input("Is "+selected+" true? "))
22                     and prove(kb,ans_body[1:],indent+" "))
23         else:
24             return any(prove(kb,cl.body+ans_body[1:],indent+" ")
25                       for cl in kb.clauses_for_atom(selected))
26     else:
27         return True # empty body is true

```

The following provides a simple **unit test** that is hard wired for `triv_KB`:

```

_____logicTopDown.py — (continued)_____
29 from logicProblem import triv_KB
30 def test():
31     a1 = prove(triv_KB,['i_am'])
32     assert a1, f"triv_KB proving i_am gave {a1}"
33     a2 = prove(triv_KB,['i_smell'])
34     assert not a2, f"triv_KB proving i_smell gave {a2}"

```

```

35     print("Passed unit tests")
36 if __name__ == "__main__":
37     test()
38 # try
39 from logicProblem import elect
40 # elect.max_display_level=3 # give detailed trace
41 # prove(elect,['live_w6'])
42 # prove(elect,['lit_l1'])

```

**Exercise 5.4** This code can re-ask a question multiple times. Implement this code so that it only asks a question once and remembers the answer. Also implement a function to forget the answers.

**Exercise 5.5** What search method is this using? Implement the search interface so that it can use  $A^*$  or other searching methods. Define an admissible heuristic that is not always 0.

## 5.4 Debugging and Explanation

Here we modify the top-down procedure to build a proof tree than can be traversed for explanation and debugging.

`prove_atom(kb,atom)` returns a proof for *atom* from a knowledge base *kb*, where a proof is a pair of the atom and the proofs for the elements of the body of the clause used to prove the atom. `prove_body(kb,body)` returns a list of proofs for list *body* from a knowledge base, *kb*. The *indent* is used when displaying the code (and doesn't need to have a non-default value).

```

_____logicExplain.py — Explaining Proof Procedure for Definite Clauses_____
11 from logicProblem import yes # for asking the user
12
13 def prove_atom(kb, atom, indent=""):
14     """returns a pair (atom,proofs) where proofs is the list of proofs
15     of the elements of a body of a clause used to prove atom.
16     """
17     kb.display(2,indent,'proving',atom)
18     if atom in kb.askables:
19         if yes(input("Is "+atom+" true? ")):
20             return (atom,"answered")
21         else:
22             return "fail"
23     else:
24         for cl in kb.clauses_for_atom(atom):
25             kb.display(2,indent,"trying",atom,'<-',' & '.join(cl.body))
26             pr_body = prove_body(kb, cl.body, indent)
27             if pr_body != "fail":
28                 return (atom, pr_body)
29         return "fail"
30
31 def prove_body(kb, ans_body, indent=""):

```

```

32     """returns proof tree if kb |- ans_body or "fail" if there is no proof
33     ans_body is a list of atoms in a body to be proved
34     """
35     proofs = []
36     for atom in ans_body:
37         proof_at = prove_atom(kb, atom, indent+" ")
38         if proof_at == "fail":
39             return "fail" # fail if any proof fails
40         else:
41             proofs.append(proof_at)
42     return proofs

```

The following provides a simple **unit test** that is hard wired for `triv_KB`:

```

_____logicExplain.py — (continued)_____
44 from logicProblem import triv_KB
45 def test():
46     a1 = prove_atom(triv_KB, 'i_am')
47     assert a1, f"triv_KB proving i_am gave {a1}"
48     a2 = prove_atom(triv_KB, 'i_smell')
49     assert a2!="fail", "triv_KB proving i_smell gave {a2}"
50     print("Passed unit tests")
51
52 if __name__ == "__main__":
53     test()
54
55 # try
56 from logicProblem import elect, elect_bug
57 # elect.max_display_level=3 # give detailed trace
58 # prove_atom(elect, 'live_w6')
59 # prove_atom(elect, 'lit_l1')

```

The `interact(kb)` provides an interactive interface to explore proofs for knowledge base `kb`. The user can ask to prove atoms and can ask how an atom was proved.

To ask how, there must be a current atom for which there is a proof. This starts as the atom asked. When the user asks “how *n*” the current atom becomes the *n*-th element of the body of the clause used to prove the (previous) current atom. The command “up” makes the current atom the atom in the head of the rule containing the (previous) current atom. Thus “how *n*” moves down the proof tree and “up” moves up the proof tree, allowing the user to explore the full proof.

```

_____logicExplain.py — (continued)_____
61 helptext = """Commands are:
62 ask atom    ask is there is a proof for atom (atom should not be in quotes)
63 how        show the clause that was used to prove atom
64 how n      show the clause used to prove the nth element of the body
65 up        go back up proof tree to explore other parts of the proof tree
66 kb        print the knowledge base

```

```

67 quit          quit this interaction (and go back to Python)
68 help         print this text
69 """
70
71 def interact(kb):
72     going = True
73     ups = [] # stack for going up
74     proof="fail" # there is no proof to start
75     while going:
76         inp = input("logicExplain: ")
77         inps = inp.split(" ")
78         try:
79             command = inps[0]
80             if command == "quit":
81                 going = False
82             elif command == "ask":
83                 proof = prove_atom(kb, inps[1])
84                 if proof == "fail":
85                     print("fail")
86                 else:
87                     print("yes")
88             elif command == "how":
89                 if proof=="fail":
90                     print("there is no proof")
91                 elif len(inps)==1:
92                     print_rule(proof)
93                 else:
94                     try:
95                         ups.append(proof)
96                         proof = proof[1][int(inps[1])] #nth argument of rule
97                         print_rule(proof)
98                     except:
99                         print('In "how n", n must be a number between 0
100                            and',len(proof[1])-1,"inclusive.")
101             elif command == "up":
102                 if ups:
103                     proof = ups.pop()
104                 else:
105                     print("No rule to go up to.")
106                     print_rule(proof)
107             elif command == "kb":
108                 print(kb)
109             elif command == "help":
110                 print(helpertext)
111             else:
112                 print("unknown command:", inp)
113                 print("use help for help")
114         except:
115             print("unknown command:", inp)
116             print("use help for help")

```

```

116
117 def print_rule(proof):
118     (head,body) = proof
119     if body == "answered":
120         print(head,"was answered yes")
121     elif body == []:
122         print(head,"is a fact")
123     else:
124         print(head,"<-")
125         for i,a in enumerate(body):
126             print(i,":",a[0])
127
128 # try
129 # interact(elect)
130 # Which clause is wrong in elect_bug? Try:
131 # interact(elect_bug)
132 # logicExplain: ask lit_l1

```

The following shows an interaction for the knowledge base elect:

```

>>> interact(elect)
logicExplain: ask lit_l1
Is up_s2 true? no
Is down_s2 true? yes
Is down_s1 true? yes
yes
logicExplain: how
lit_l1 <-
0 : light_l1
1 : live_l1
2 : ok_l1
logicExplain: how 1
live_l1 <-
0 : live_w0
logicExplain: how 0
live_w0 <-
0 : down_s2
1 : live_w2
logicExplain: how 0
down_s2 was answered yes
logicExplain: up
live_w0 <-
0 : down_s2
1 : live_w2
logicExplain: how 1
live_w2 <-
0 : down_s1
1 : live_w3

```

```
logicExplain: quit
>>>
```

**Exercise 5.6** The above code only ever explores one proof – the first proof found. Change the code to enumerate the proof trees (by returning a list of all proof trees, or, preferably, using `yield`). Add the command “retry” to the user interface to try another proof.

## 5.5 Assumables

Atom  $a$  can be made assumable by including  $Assumable(a)$  in the knowledge base. A knowledge base that can include assumables is declared with  $KBA$ .

```

_____logicAssumables.py — Definite clauses with assumables_____
11 from logicProblem import Clause, Askable, KB, yes
12
13 class Assumable(object):
14     """An askable atom"""
15
16     def __init__(self,atom):
17         """clause with atom head and lost of atoms body"""
18         self.atom = atom
19
20     def __str__(self):
21         """returns the string representation of a clause.
22         """
23         return "assumable " + self.atom + "."
24
25 class KBA(KB):
26     """A knowledge base that can include assumables"""
27     def __init__(self,statements):
28         self.assumables = [c.atom for c in statements if isinstance(c,
29             Assumable)]
30         KB.__init__(self,statements)

```

The top-down Horn clause interpreter, `prove_all_ass` returns a list of the sets of assumables that imply `ans_body`. This list will contain all of the minimal sets of assumables, but can also find non-minimal sets, and repeated sets, if they can be generated with separate proofs. The set `assumed` is the set of assumables already assumed.

```

_____logicAssumables.py — (continued)_____
31 def prove_all_ass(self, ans_body, assumed=set()):
32     """returns a list of sets of assumables that extends assumed
33     to imply ans_body from self.
34     ans_body is a list of atoms (it is the body of the answer clause).
35     assumed is a set of assumables already assumed
36     """
37     if ans_body:

```

```

38     selected = ans_body[0] # select first atom from ans_body
39     if selected in self.askables:
40         if yes(input("Is "+selected+" true? ")):
41             return self.prove_all_ass(ans_body[1:], assumed)
42         else:
43             return [] # no answers
44     elif selected in self.assumables:
45         return self.prove_all_ass(ans_body[1:], assumed|{selected})
46     else:
47         return [ass
48                 for cl in self.clauses_for_atom(selected)
49                 for ass in
50                     self.prove_all_ass(cl.body+ans_body[1:], assumed)
51                     ] # union of answers for each clause with
52                     head=selected
53     else:
54         # empty body
55         return [assumed] # one answer
56
57 def conflicts(self):
58     """returns a list of minimal conflicts"""
59     return minsets(self.prove_all_ass(['false']))

```

Given a list of sets, *minsets* returns a list of the minimal sets in the list. For example, *minsets*([ $\{2,3,4\}$ ,  $\{2,3\}$ ,  $\{6,2,3\}$ ,  $\{2,3\}$ ,  $\{2,4,5\}$ ]) returns [ $\{2,3\}$ ,  $\{2,4,5\}$ ].

---

logicAssumables.py — (continued)

---

```

58 def minsets(ls):
59     """ls is a list of sets
60     returns a list of minimal sets in ls
61     """
62     ans = [] # elements known to be minimal
63     for c in ls:
64         if not any(c1<c for c1 in ls) and not any(c1 <= c for c1 in ans):
65             ans.append(c)
66     return ans
67
68 # minsets([{2, 3, 4}, {2, 3}, {6, 2, 3}, {2, 3}, {2, 4, 5}])

```

Warning: *minsets* works for a list of sets or for a set of (frozen) sets, but it does not work for a generator of sets (because *ls* is referenced in the loop). For example, try to predict and then test:

```
minsets(e for e in [{2, 3, 4}, {2, 3}, {6, 2, 3}, {2, 3}, {2, 4, 5}])
```

The diagnoses can be constructed from the (minimal) conflicts as follows. This also works if there are non-minimal conflicts, but is not as efficient.

---

logicAssumables.py — (continued)

---

```

69 def diagnoses(cons):
70     """cons is a list of (minimal) conflicts.
71     returns a list of diagnoses."""
72     if cons == []:

```

```

73     return [set()]
74     else:
75         return minsets([(e)|d]          # | is set union
76                        for e in cons[0]
77                        for d in diagnoses(cons[1:]))

```

Test cases:

---

```

                                logicAssumables.py — (continued)
80 electa = KBA([
81     Clause('light_l1'),
82     Clause('light_l2'),
83     Assumable('ok_l1'),
84     Assumable('ok_l2'),
85     Assumable('ok_s1'),
86     Assumable('ok_s2'),
87     Assumable('ok_s3'),
88     Assumable('ok_cb1'),
89     Assumable('ok_cb2'),
90     Assumable('live_outside'),
91     Clause('live_l1', ['live_w0']),
92     Clause('live_w0', ['up_s2', 'ok_s2', 'live_w1']),
93     Clause('live_w0', ['down_s2', 'ok_s2', 'live_w2']),
94     Clause('live_w1', ['up_s1', 'ok_s1', 'live_w3']),
95     Clause('live_w2', ['down_s1', 'ok_s1', 'live_w3' ]),
96     Clause('live_l2', ['live_w4']),
97     Clause('live_w4', ['up_s3', 'ok_s3', 'live_w3' ]),
98     Clause('live_p1', ['live_w3']),
99     Clause('live_w3', ['live_w5', 'ok_cb1']),
100    Clause('live_p2', ['live_w6']),
101    Clause('live_w6', ['live_w5', 'ok_cb2']),
102    Clause('live_w5', ['live_outside']),
103    Clause('lit_l1', ['light_l1', 'live_l1', 'ok_l1']),
104    Clause('lit_l2', ['light_l2', 'live_l2', 'ok_l2']),
105    Askable('up_s1'),
106    Askable('down_s1'),
107    Askable('up_s2'),
108    Askable('down_s2'),
109    Askable('up_s3'),
110    Askable('down_s2'),
111    Askable('dark_l1'),
112    Askable('dark_l2'),
113    Clause('false', ['dark_l1', 'lit_l1']),
114    Clause('false', ['dark_l2', 'lit_l2'])
115    ])
116 # electa.prove_all_ass(['false'])
117 # cs=electa.conflicts()
118 # print(cs)
119 # diagnoses(cs)      # diagnoses from conflicts

```

**Exercise 5.7** To implement a version of *conflicts* that never generates non-minimal

conflicts, modify `prove_all_ass` to implement iterative deepening on the number of assumables used in a proof, and prune any set of assumables that is a superset of a conflict.

**Exercise 5.8** Implement `explanations(self, body)`, where `body` is a list of atoms, that returns a list of the minimal explanations of the body. This does not require modification of `prove_all_ass`.

**Exercise 5.9** Implement `explanations`, as in the previous question, so that it never generates non-minimal explanations. Hint: modify `prove_all_ass` to implement iterative deepening on the number of assumptions, generating conflicts and explanations together, and pruning as early as possible.

## 5.6 Negation-as-failure

The negation of an atom `a` is written as `Not(a)` in a body.

```

logicNegation.py — Propositional negation-as-failure
11 from logicProblem import KB, Clause, Askable, yes
12
13 class Not(object):
14     def __init__(self, atom):
15         self.theatom = atom
16
17     def atom(self):
18         return self.theatom
19
20     def __repr__(self):
21         return f"Not({self.theatom})"

```

Prove with negation-as-failure (`prove_naf`) is like `prove`, but with the extra case to cover `Not`:

```

logicNegation.py — (continued)
23 def prove_naf(kb, ans_body, indent=""):
24     """ prove with negation-as-failure and askables
25     returns True if kb |- ans_body
26     ans_body is a list of atoms to be proved
27     """
28     kb.display(2, indent, 'yes <- ', ' & '.join(str(e) for e in ans_body))
29     if ans_body:
30         selected = ans_body[0] # select first atom from ans_body
31         if isinstance(selected, Not):
32             kb.display(2, indent, f"proving {selected.atom()}")
33             if prove_naf(kb, [selected.atom()], indent):
34                 kb.display(2, indent, f"{selected.atom()} succeeded so
35                 Not({selected.atom()}) fails")
36                 return False
37         else:
38             kb.display(2, indent, f"{selected.atom()} fails so
39             Not({selected.atom()}) succeeds")

```

```

38         return prove_naf(kb, ans_body[1:], indent+" ")
39     if selected in kb.askables:
40         return (yes(input("Is "+selected+" true? "))
41                 and prove_naf(kb, ans_body[1:], indent+" "))
42     else:
43         return any(prove_naf(kb, cl.body+ans_body[1:], indent+" ")
44                   for cl in kb.clauses_for_atom(selected))
45 else:
46     return True # empty body is true

```

Test cases:

```

----- logicNegation.py --- (continued) -----
48 triv_KB_naf = KB([
49     Clause('i_am', ['i_think']),
50     Clause('i_think'),
51     Clause('i_smell', ['i_am', Not('dead')]),
52     Clause('i_bad', ['i_am', Not('i_think')])
53 ])
54
55 triv_KB_naf.max_display_level = 4
56 def test():
57     a1 = prove_naf(triv_KB_naf, ['i_smell'])
58     assert a1, f"triv_KB_naf proving i_smell gave {a1}"
59     a2 = prove_naf(triv_KB_naf, ['i_bad'])
60     assert not a2, f"triv_KB_naf proving i_bad gave {a2}"
61     print("Passed unit tests")
62 if __name__ == "__main__":
63     test()

```

Default reasoning about beaches at resorts (Example 5.28 of Poole and Mackworth [2023]):

```

----- logicNegation.py --- (continued) -----
65 beach_KB = KB([
66     Clause('away_from_beach', [Not('on_beach')]),
67     Clause('beach_access', ['on_beach', Not('ab_beach_access')]),
68     Clause('swim_at_beach', ['beach_access', Not('ab_swim_at_beach')]),
69     Clause('ab_swim_at_beach', ['enclosed_bay', 'big_city',
70                               Not('ab_no_swimming_near_city')]),
71     Clause('ab_no_swimming_near_city', ['in_BC', Not('ab_BC_beaches')])
72 ])
73 # prove_naf(beach_KB, ['away_from_beach'])
74 # prove_naf(beach_KB, ['beach_access'])
75 # beach_KB.add_clause(Clause('on_beach', []))
76 # prove_naf(beach_KB, ['away_from_beach'])
77 # prove_naf(beach_KB, ['swim_at_beach'])
78 # beach_KB.add_clause(Clause('enclosed_bay', []))
79 # prove_naf(beach_KB, ['swim_at_beach'])
80 # beach_KB.add_clause(Clause('big_city', []))
81 # prove_naf(beach_KB, ['swim_at_beach'])

```

```
82 | # beach_KB.add_clause(Clause('in_BC', []))  
83 | # prove_naf(beach_KB, ['swim_at_beach'])
```

## Deterministic Planning

### 6.1 Representing Actions and Planning Problems

The STRIPS representation of an action consists of:

- the name of the action
- preconditions: a dictionary of *feature:value* pairs that specifies that the feature must have this value for the action to be possible
- effects: a dictionary of *feature:value* pairs that are made true by this action. In particular, a feature in the dictionary has the corresponding value (and not its previous value) after the action, and a feature not in the dictionary keeps its old value.

```
stripsProblem.py — STRIPS Representations of Actions
11 class Strips(object):
12     def __init__(self, name, preconds, effects, cost=1):
13         """
14         defines the STRIPS representation for an action:
15         * name is the name of the action
16         * preconds, the preconditions, is feature:value dictionary that
           must hold
17         for the action to be carried out
18         * effects is a feature:value map that this action makes
19         true. The action changes the value of any feature specified
20         here, and leaves other features unchanged.
21         * cost is the cost of the action
22         """
```

```

23     self.name = name
24     self.preconds = preconds
25     self.effects = effects
26     self.cost = cost
27
28     def __repr__(self):
29         return self.name

```

A STRIPS domain consists of:

- A dictionary that maps each feature into a set of possible values for the feature.
- A set of actions, each represented using the Strips class.

```

_____stripsProblem.py — (continued)_____
31 class STRIPS_domain(object):
32     def __init__(self, feature_domain_dict, actions):
33         """Problem domain
34         feature_domain_dict is a feature:domain dictionary,
35         mapping each feature to its domain
36         actions
37         """
38         self.feature_domain_dict = feature_domain_dict
39         self.actions = actions

```

A planning problem consists of a planning domain, an initial state, and a goal. The goal does not need to fully specify the final state.

```

_____stripsProblem.py — (continued)_____
41 class Planning_problem(object):
42     def __init__(self, prob_domain, initial_state, goal):
43         """
44         a planning problem consists of
45         * a planning domain
46         * the initial state
47         * a goal
48         """
49         self.prob_domain = prob_domain
50         self.initial_state = initial_state
51         self.goal = goal

```

### 6.1.1 Robot Delivery Domain

The following specifies the robot delivery domain of Section 6.1, shown in Figure 6.1.

```

_____stripsProblem.py — (continued)_____
53 boolean = {False, True}
54 delivery_domain = STRIPS_domain(

```

**Features to describe states***RLoc* – Rob's location*RHC* – Rob has coffee*SWC* – Sam wants coffee*MW* – Mail is waiting*RHM* – Rob has mail**Actions***mc* – move clockwise*mcc* – move counterclockwise*puc* – pickup coffee*dc* – deliver coffee*pum* – pickup mail*dm* – deliver mail

Figure 6.1: Robot Delivery Domain

```

55 |     {'RLoc':{'cs', 'off', 'lab', 'mr'}, 'RHC':boolean, 'SWC':boolean,
56 |       'MW':boolean, 'RHM':boolean}, #feature:values dictionary
57 |     { Strips('mc_cs', {'RLoc':'cs'}, {'RLoc':'off'}),
58 |       Strips('mc_off', {'RLoc':'off'}, {'RLoc':'lab'}),
59 |       Strips('mc_lab', {'RLoc':'lab'}, {'RLoc':'mr'}),
60 |       Strips('mc_mr', {'RLoc':'mr'}, {'RLoc':'cs'}),
61 |       Strips('mcc_cs', {'RLoc':'cs'}, {'RLoc':'mr'}),
62 |       Strips('mcc_off', {'RLoc':'off'}, {'RLoc':'cs'}),
63 |       Strips('mcc_lab', {'RLoc':'lab'}, {'RLoc':'off'}),
64 |       Strips('mcc_mr', {'RLoc':'mr'}, {'RLoc':'lab'}),
65 |       Strips('puc', {'RLoc':'cs', 'RHC':False}, {'RHC':True}),
66 |       Strips('dc', {'RLoc':'off', 'RHC':True}, {'RHC':False, 'SWC':False}),
67 |       Strips('pum', {'RLoc':'mr', 'MW':True}, {'RHM':True, 'MW':False}),
68 |       Strips('dm', {'RLoc':'off', 'RHM':True}, {'RHM':False})
69 |     } )

```

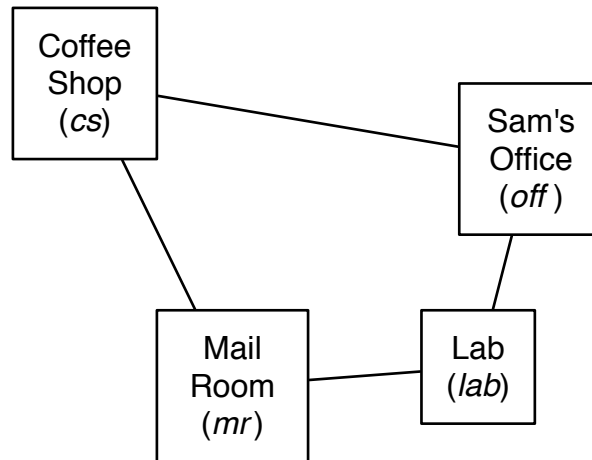
stripsProblem.py — (continued)

```

71 | problem0 = Planning_problem(delivery_domain,
72 |                             {'RLoc':'lab', 'MW':True, 'SWC':True, 'RHC':False,
73 |                             'RHM':False},

```

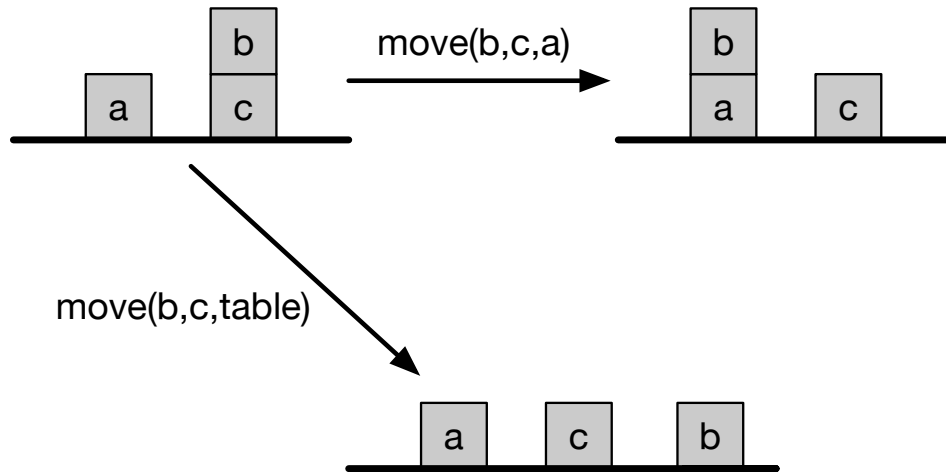

Figure 6.2: Blocks world with two actions

```

74         {'RLoc': 'off'})
75 problem1 = Planning_problem(delivery_domain,
76                             {'RLoc': 'lab', 'MW': True, 'SWC': True, 'RHC': False,
77                              'RHM': False},
78                             {'SWC': False})
79 problem2 = Planning_problem(delivery_domain,
80                             {'RLoc': 'lab', 'MW': True, 'SWC': True, 'RHC': False,
81                              'RHM': False},
82                             {'SWC': False, 'MW': False, 'RHM': False})

```

### 6.1.2 Blocks World

The blocks world consist of blocks and a table. Each block can be on the table or on another block. A block can only have one other block on top of it. Figure 6.2 shows 3 states with some of the actions between them.

A state is defined by the two features:

- *on* where  $on(x) = y$  when block  $x$  is on block or table  $y$
- *clear* where  $clear(x) = True$  when block  $x$  has nothing on it.

There is one parameterized action

- $move(x, y, z)$  move block  $x$  from  $y$  to  $z$ , where  $y$  and  $z$  could be a block or the table.

To handle parameterized actions (which depend on the blocks involved), the actions and the features are all strings, created for all the combinations of the blocks. Note that we treat moving to a block separately from moving to the

table, because the blocks needs to be clear, but the table always has room for another block.

```

stripsProblem.py — (continued)
84 ### blocks world
85 def move(x,y,z):
86     """string for the 'move' action"""
87     return 'move_'+x+'_from_'+y+'_to_'+z
88 def on(x):
89     """string for the 'on' feature"""
90     return x+'_is_on'
91 def clear(x):
92     """string for the 'clear' feature"""
93     return 'clear_'+x
94 def create_blocks_world(blocks = {'a','b','c','d'}):
95     blocks_and_table = blocks | {'table'}
96     stmap = {Strips(move(x,y,z),{on(x):y, clear(x):True, clear(z):True},
97                 {on(x):z, clear(y):True, clear(z):False})
98             for x in blocks
99             for y in blocks_and_table
100            for z in blocks
101            if x!=y and y!=z and z!=x}
102     stmap.update({Strips(move(x,y,'table'), {on(x):y, clear(x):True},
103                 {on(x):'table', clear(y):True})
104                for x in blocks
105                for y in blocks
106                if x!=y})
107     feature_domain_dict = {on(x):blocks_and_table-{x} for x in blocks}
108     feature_domain_dict.update({clear(x):boolean for x in blocks_and_table})
109     return STRIPS_domain(feature_domain_dict, stmap)

```

The problem *blocks1* is a classic example, with 3 blocks, and the goal consists of two conditions. See Figure 6.3. This example is challenging because you can't achieve one of the goals and then the other; whichever one you achieve first has to be undone to achieve the second.

```

stripsProblem.py — (continued)
111 blocks1dom = create_blocks_world({'a','b','c'})
112 blocks1 = Planning_problem(blocks1dom,
113     {on('a'):'table', clear('a'):True,
114     on('b'):'c', clear('b'):True,
115     on('c'):'table', clear('c'):False}, # initial state
116     {on('a'):'b', on('c'):'a'}) #goal

```

The problem *blocks2* is one to invert a tower of size 4.

```

stripsProblem.py — (continued)
118 blocks2dom = create_blocks_world({'a','b','c','d'})
119 tower4 = {clear('a'):True, on('a'):'b',
120           clear('b'):False, on('b'):'c',
121           clear('c'):False, on('c'):'d',

```

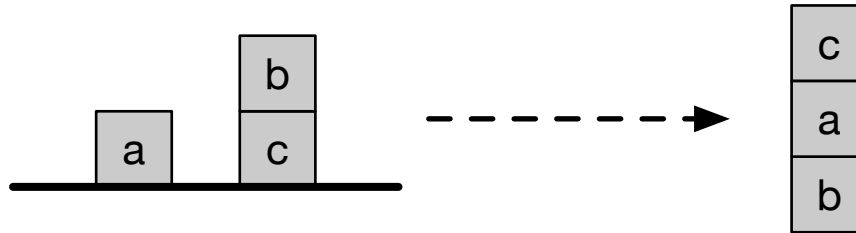

Figure 6.3: Blocks problem blocks1

```

122 |         clear('d'):False, on('d'):'table'}
123 | blocks2 = Planning_problem(blocks2dom,
124 |     tower4, # initial state
125 |     {on('d'):'c', on('c'):'b', on('b'):'a'}) #goal

```

The problem *blocks3* is to move the bottom block to the top of a tower of size 4.

```

stripsProblem.py — (continued)
127 | blocks3 = Planning_problem(blocks2dom,
128 |     tower4, # initial state
129 |     {on('d'):'a', on('a'):'b', on('b'):'c'}) #goal

```

**Exercise 6.1** Represent the problem of given a tower of 4 blocks (*a* on *b* on *c* on *d* on table), the goal is to have a tower with the previous top block on the bottom (*b* on *c* on *d* on *a*). Do not include the table in your goal (the goal does not care whether *a* is on the table). [Before you run the program, estimate how many steps it will take to solve this.] How many steps does an optimal planner take?

**Exercise 6.2** Represent the domain so that *on(x,y)* is a Boolean feature that is True when *x* is on *y*. Does the representation of the state need to include negative *on* facts? Why or why not? (Note that this may depend on the planner; write your answer with respect to particular planners.)

**Exercise 6.3** It is possible to write the representation of the problem without using *clear*, where *clear(x)* means nothing is on *x*. Change the definition of the blocks world so that it does not use *clear* but uses *on* being false instead. Does this work better for any of the planners?

## 6.2 Forward Planning

To run the demo, in folder "aipython", load "stripsForwardPlanner.py", and copy and paste the commented-out example queries at the bottom of that file.

In a forward planner, a node is a state. A state consists of an assignment, which is a variable:value dictionary. In order to be able to do multiple-path pruning, we need to define a hash function, and equality between states.

stripsForwardPlanner.py — Forward Planner with STRIPS actions

```

11 from searchProblem import Arc, Search_problem
12 from stripsProblem import Strips, STRIPS_domain
13
14 class State(object):
15     def __init__(self, assignment):
16         self.assignment = assignment
17         self.hash_value = None
18     def __hash__(self):
19         if self.hash_value is None:
20             self.hash_value = hash(frozenset(self.assignment.items()))
21         return self.hash_value
22     def __eq__(self, st):
23         return self.assignment == st.assignment
24     def __str__(self):
25         return str(self.assignment)

```

In order to define a search problem (page 41), we need to define the goal condition, the start nodes, the neighbours, and (optionally) a heuristic function. Here *zero* is the default heuristic function.

stripsForwardPlanner.py — (continued)

```

27 def zero(*args, **nargs):
28     """always returns 0"""
29     return 0
30
31 class Forward_STRIPS(Search_problem):
32     """A search problem from a planning problem where:
33     * a node is a state object.
34     * the dynamics are specified by the STRIPS representation of actions
35     """
36     def __init__(self, planning_problem, heur=zero):
37         """creates a forward search space from a planning problem.
38         heur(state,goal) is a heuristic function,
39         an underestimate of the cost from state to goal, where
40         both state and goals are feature:value dictionaries.
41         """
42         self.prob_domain = planning_problem.prob_domain
43         self.initial_state = State(planning_problem.initial_state)
44         self.goal = planning_problem.goal
45         self.heur = heur
46
47     def is_goal(self, state):
48         """is True if node is a goal.
49
50         Every goal feature has the same value in the state and the goal."""
51         return all(state.assignment[prop]==self.goal[prop]
52                   for prop in self.goal)
53
54     def start_node(self):
55         """returns start node"""

```

```

56     return self.initial_state
57
58     def neighbors(self, state):
59         """returns neighbors of state in this problem"""
60         return [ Arc(state, self.effect(act, state.assignment), act.cost,
61                   act)
62                 for act in self.prob_domain.actions
63                 if self.possible(act, state.assignment)]
64
65     def possible(self, act, state_asst):
66         """True if act is possible in state.
67         act is possible if all of its preconditions have the same value in
68         the state"""
69         return all(state_asst[pre] == act.preconds[pre]
70                   for pre in act.preconds)
71
72     def effect(self, act, state_asst):
73         """returns the state that is the effect of doing act given
74         state_asst
75         Python 3.9: return state_asst | act.effects"""
76         new_state_asst = state_asst.copy()
77         new_state_asst.update(act.effects)
78         return State(new_state_asst)
79
80     def heuristic(self, state):
81         """in the forward planner a node is a state.
82         the heuristic is an (under)estimate of the cost
83         of going from the state to the top-level goal.
84         """
85         return self.heur(state.assignment, self.goal)

```

Here are some test cases to try.

```

_____stripsForwardPlanner.py — (continued)_____
84 from searchBranchAndBound import DF_branch_and_bound
85 from searchMPP import SearcherMPP
86 import stripsProblem
87
88 # SearcherMPP(Forward_STRIPS(stripsProblem.problem1)).search() #A* with MPP
89 # DF_branch_and_bound(Forward_STRIPS(stripsProblem.problem1), 10).search()
90 #B&B
91 # To find more than one plan:
92 # s1 = SearcherMPP(Forward_STRIPS(stripsProblem.problem1)) #A*
93 # s1.search() #find another plan

```

### 6.2.1 Defining Heuristics for a Planner

Each planning domain requires its own heuristics. If you change the actions, you will need to reconsider the heuristic function, as there might then be a lower-cost path, which might make the heuristic non-admissible.

Here is an example of defining heuristics for the coffee delivery planning domain.

First we define the distance between two locations, which is used for the heuristics.

```

stripsHeuristic.py — Planner with Heuristic Function
11 def dist(loc1, loc2):
12     """returns the distance from location loc1 to loc2
13     """
14     if loc1==loc2:
15         return 0
16     if {loc1,loc2} in [{'cs','lab'},{'mr','off'}]:
17         return 2
18     else:
19         return 1

```

Note that the current state is a complete description; there is a value for every feature. However the goal need not be complete; it does not need to define a value for every feature. Before checking the value for a feature in the goal, a heuristic needs to define whether the feature is defined in the goal.

```

stripsHeuristic.py — (continued)
21 def h1(state,goal):
22     """ the distance to the goal location, if there is one"""
23     if 'RLoc' in goal:
24         return dist(state['RLoc'], goal['RLoc'])
25     else:
26         return 0
27
28 def h2(state,goal):
29     """ the distance to the coffee shop plus getting coffee and delivering
30     it
31     if the robot needs to get coffee
32     """
33     if ('SWC' in goal and goal['SWC']==False
34         and state['SWC']==True
35         and state['RHC']==False):
36         return dist(state['RLoc'],'cs')+3
37     else:
38         return 0

```

The maximum of the values of a set of admissible heuristics is also an admissible heuristic. The function `maxh` takes a number of heuristic functions as arguments, and returns a new heuristic function that takes the maximum of the values of the heuristics. For example, `h1` and `h2` are heuristic functions and so `maxh(h1,h2)` is also. `maxh` can take an arbitrary number of arguments.

```

stripsHeuristic.py — (continued)
39 def maxh(*heuristics):
40     """Returns a new heuristic function that is the maximum of the
    functions in heuristics.

```

```

41 | heuristics is the list of arguments which must be heuristic functions.
42 | """
43 | # return lambda state,goal: max(h(state,goal) for h in heuristics)
44 | def newh(state,goal):
45 |     return max(h(state,goal) for h in heuristics)
46 | return newh

```

The following runs the example with and without the heuristic.

```

stripsHeuristic.py — (continued)
48 | ##### Forward Planner #####
49 | from searchMPP import SearcherMPP
50 | from stripsForwardPlanner import Forward_STRIPS
51 | import stripsProblem
52 |
53 | def test_forward_heuristic(thisproblem=stripsProblem.problem1):
54 |     print("\n***** FORWARD NO HEURISTIC")
55 |     print(SearcherMPP(Forward_STRIPS(thisproblem)).search())
56 |
57 |     print("\n***** FORWARD WITH HEURISTIC h1")
58 |     print(SearcherMPP(Forward_STRIPS(thisproblem,h1)).search())
59 |
60 |     print("\n***** FORWARD WITH HEURISTIC h2")
61 |     print(SearcherMPP(Forward_STRIPS(thisproblem,h2)).search())
62 |
63 |     print("\n***** FORWARD WITH HEURISTICS h1 and h2")
64 |     print(SearcherMPP(Forward_STRIPS(thisproblem,maxh(h1,h2))).search())
65 |
66 | if __name__ == "__main__":
67 |     test_forward_heuristic()

```

**Exercise 6.4** For more than one start-state/goal combination, test the forward planner with a heuristic function of just  $h_1$ , with just  $h_2$  and with both. Explain why each one prunes or doesn't prune the search space.

**Exercise 6.5** Create a better heuristic than  $\max(h_1, h_2)$ . Try it for a number of different problems. In particular, try and include the following costs:

- i)  $h_3$  is like  $h_2$  but also takes into account the case when  $Rloc$  is in goal.
- ii)  $h_4$  uses the distance to the mail room plus getting mail and delivering it if the robot needs to get need to deliver mail.
- iii)  $h_5$  is for getting mail when goal is for the robot to have mail, and then getting to the goal destination (if there is one).

**Exercise 6.6** Create an admissible heuristic for the blocks world.

## 6.3 Regression Planning

To run the demo, in folder "aipython", load "stripsRegressionPlanner.py", and copy and paste the commented-out example queries at the bottom of that file.

In a regression planner a node is a subgoal that need to be achieved.

A *Subgoal* object consists of an assignment, which is a *variable:value* dictionary. We make it hashable so that multiple path pruning can work. The hash is only computed when necessary (and only once).

```

_____stripsRegressionPlanner.py — Regression Planner with STRIPS actions _____
11 from searchProblem import Arc, Search_problem
12
13 class Subgoal(object):
14     def __init__(self, assignment):
15         self.assignment = assignment
16         self.hash_value = None
17     def __hash__(self):
18         if self.hash_value is None:
19             self.hash_value = hash(frozenset(self.assignment.items()))
20         return self.hash_value
21     def __eq__(self, st):
22         return self.assignment == st.assignment
23     def __str__(self):
24         return str(self.assignment)

```

A regression search has subgoals as nodes. The initial node is the top-level goal of the planner. The goal for the search (when the search can stop) is a subgoal that holds in the initial state.

```

_____stripsRegressionPlanner.py — (continued) _____
26 from stripsForwardPlanner import zero
27
28 class Regression_STRIPS(Search_problem):
29     """A search problem where:
30     * a node is a goal to be achieved, represented by a set of propositions.
31     * the dynamics are specified by the STRIPS representation of actions
32     """
33
34     def __init__(self, planning_problem, heur=zero):
35         """creates a regression search space from a planning problem.
36         heur(state,goal) is a heuristic function;
37         an underestimate of the cost from state to goal, where
38         both state and goals are feature:value dictionaries
39         """
40         self.prob_domain = planning_problem.prob_domain
41         self.top_goal = Subgoal(planning_problem.goal)
42         self.initial_state = planning_problem.initial_state
43         self.heur = heur

```

```

44
45 def is_goal(self, subgoal):
46     """if subgoal is true in the initial state, a path has been found"""
47     goal_asst = subgoal.assignment
48     return all(self.initial_state[g]==goal_asst[g]
49                 for g in goal_asst)
50
51 def start_node(self):
52     """the start node is the top-level goal"""
53     return self.top_goal
54
55 def neighbors(self,subgoal):
56     """returns a list of the arcs for the neighbors of subgoal in this
57         problem"""
58     goal_asst = subgoal.assignment
59     return [ Arc(subgoal, self.weakest_precond(act,goal_asst),
60                act.cost, act)
61              for act in self.prob_domain.actions
62              if self.possible(act,goal_asst)]
63
64 def possible(self,act,goal_asst):
65     """True if act is possible to achieve goal_asst.
66
67     the action achieves an element of the effects and
68     the action doesn't delete something that needs to be achieved and
69     the preconditions are consistent with other subgoals that need to
70     be achieved
71     """
72     return ( any(goal_asst[prop] == act.effects[prop]
73                 for prop in act.effects if prop in goal_asst)
74             and all(goal_asst[prop] == act.effects[prop]
75                     for prop in act.effects if prop in goal_asst)
76             and all(goal_asst[prop]== act.preconds[prop]
77                     for prop in act.preconds if prop not in act.effects
78                     and prop in goal_asst)
79             )
80
81 def weakest_precond(self,act,goal_asst):
82     """returns the subgoal that must be true so goal_asst holds after
83         act
84         should be: act.preconds | (goal_asst - act.effects)
85     """
86     new_asst = act.preconds.copy()
87     for g in goal_asst:
88         if g not in act.effects:
89             new_asst[g] = goal_asst[g]
90     return Subgoal(new_asst)
91
92 def heuristic(self,subgoal):
93     """in the regression planner a node is a subgoal.

```

```

89         the heuristic is an (under)estimate of the cost of going from the
90         initial state to subgoal.
91         """
92         return self.heur(self.initial_state, subgoal.assignment)

```

---

```

stripsRegressionPlanner.py — (continued)
93 from searchBranchAndBound import DF_branch_and_bound
94 from searchMPP import SearcherMPP
95 import stripsProblem
96
97 # SearcherMPP(Regression_STRIPS(stripsProblem.problem1)).search() #A* with
98 # MPP
99 # DF_branch_and_bound(Regression_STRIPS(stripsProblem.problem1),10).search()
100 #B&B

```

**Exercise 6.7** Multiple path pruning could be used to prune more than the current node. In particular, if the current node contains more conditions than a previously visited node, it can be pruned. For example, if  $\{a : True, b : False\}$  has been visited, then any node that is a superset, e.g.,  $\{a : True, b : False, d : True\}$ , need not be expanded. If the simpler subgoal does not lead to a solution, the more complicated one will not either. Implement this more severe pruning. (Hint: This may require modifications to the searcher.)

**Exercise 6.8** It is possible that, as knowledge of the domain, that some assignment of values to variables can never be achieved. For example, the robot cannot be holding mail when there is mail waiting (assuming it isn't holding mail initially). An assignment of values to (some of the) variables is incompatible if no possible (reachable) state can include that assignment. For example,  $\{MW' : True, RHM' : True\}$  is an incompatible assignment. This information may be useful information for a planner; there is no point in trying to achieve these together. Define a subclass of *STRIPS\_domain* that can accept a list of incompatible assignments. Modify the regression planner code to use such a list of incompatible assignments. Give an example where the search space is smaller.

**Exercise 6.9** After completing the previous exercise, design incompatible assignments for the blocks world. (This should result in dramatic search improvements.)

### 6.3.1 Defining Heuristics for a Regression Planner

The regression planner can use the same heuristic function as the forward planner. However, just because a heuristic is useful for a forward planner does not mean it is useful for a regression planner, and vice versa. you should experiment with whether the same heuristic works well for both a regression planner and a forward planner.

The following runs the same example as the forward planner with and without the heuristic defined for the forward planner:

---

```
stripsHeuristic.py — (continued)
```

```

69 ##### Regression Planner
70 from stripsRegressionPlanner import Regression_STRIPS
71
72 def test_regression_heuristic(thisproblem=stripsProblem.problem1):
73     print("\n***** REGRESSION NO HEURISTIC")
74     print(SearcherMPP(Regression_STRIPS(thisproblem)).search())
75
76     print("\n***** REGRESSION WITH HEURISTICS h1 and h2")
77     print(SearcherMPP(Regression_STRIPS(thisproblem,maxh(h1,h2))).search())
78
79 if __name__ == "__main__":
80     test_regression_heuristic()

```

**Exercise 6.10** Try the regression planner with a heuristic function of just  $h1$  and with just  $h2$  (defined in Section 6.2.1). Explain how each one prunes or doesn't prune the search space.

**Exercise 6.11** Create a better heuristic than *heuristic.fun* defined in Section 6.2.1.

## 6.4 Planning as a CSP

To run the demo, in folder "aipython", load "stripsCSPPlanner.py", and copy and paste the commented-out example queries at the bottom of that file. This assumes Python 3.

Here we implement the CSP planner assuming there is a single action at each step. This creates a CSP that can use any of the CSP algorithms to solve (e.g., stochastic local search or arc consistency with domain splitting).

This assumes the same action representation as before; we do not consider factored actions (action features), nor do we implement state constraints.

```

_____stripsCSPPlanner.py — CSP planner where actions are represented using STRIPS_____
11 from cspProblem import Variable, CSP, Constraint
12
13 class CSP_from_STRIPS(CSP):
14     """A CSP where:
15     * CSP variables are constructed for each feature and time, and each
16       action and time
17     * the dynamics are specified by the STRIPS representation of actions
18     """
19
20     def __init__(self, planning_problem, number_stages=2):
21         prob_domain = planning_problem.prob_domain
22         initial_state = planning_problem.initial_state
23         goal = planning_problem.goal
24         # self.action_vars[t] is the action variable for time t
25         self.action_vars = [Variable(f"Action{t}", prob_domain.actions)
26                             for t in range(number_stages)]
27         # feat_time_var[f][t] is the variable for feature f at time t

```

```

27     feat_time_var = {feat: [Variable(f"{feat}_{t}", dom)
28                             for t in range(number_stages+1)]
29                       for (feat, dom) in
30                           prob_domain.feature_domain_dict.items()}
31
32     # initial state constraints:
33     constraints = [Constraint((feat_time_var[feat][0],), is_(val))
34                       for (feat, val) in initial_state.items())
35
36     # goal constraints on the final state:
37     constraints += [Constraint((feat_time_var[feat][number_stages],),
38                               is_(val))
39                       for (feat, val) in goal.items())
40
41     # precondition constraints:
42     constraints += [Constraint((feat_time_var[feat][t],
43                               self.action_vars[t]),
44                               if_(val, act)) # feat@t==val if action@t==act
45                       for act in prob_domain.actions
46                       for (feat, val) in act.preconds.items()
47                       for t in range(number_stages)]
48
49     # effect constraints:
50     constraints += [Constraint((feat_time_var[feat][t+1],
51                               self.action_vars[t]),
52                               if_(val, act)) # feat@t+1==val if
53                                       action@t==act
54                       for act in prob_domain.actions
55                       for feat, val in act.effects.items()
56                       for t in range(number_stages)]
57
58     # frame constraints:
59     constraints += [Constraint((feat_time_var[feat][t],
60                               self.action_vars[t], feat_time_var[feat][t+1]),
61                               eq_if_not_in_({act for act in
62                                               prob_domain.actions
63                                               if feat in act.effects}))
64                       for feat in prob_domain.feature_domain_dict
65                       for t in range(number_stages) ]
66
67     variables = set(self.action_vars) | {feat_time_var[feat][t]
68                                         for feat in
69                                             prob_domain.feature_domain_dict
70                                             for t in range(number_stages+1)}
71
72     CSP.__init__(self, "CSP_from_Strips", variables, constraints)
73
74     def extract_plan(self, soln):
75         return [soln[a] for a in self.action_vars]

```

The following methods return methods which can be applied to the particular environment.

For example, `is_(3)` returns a function that when applied to 3, returns True

and when applied to any other value returns False. So `is_(3)(3)` returns `True` and `is_(3)(7)` returns `False`.

Note that the underscore (`'_'`) is part of the name; here we use it as the convention that it is a function that returns a function. This uses two different styles to define `is_` and `if_`; returning a function defined by `lambda` is equivalent to returning the embedded function, except that the embedded function has a name. The embedded function can also be given a docstring.

```

stripsCSPPlanner.py — (continued)
68 def is_(val):
69     """returns a function that is true when it is it applied to val.
70     """
71     #return lambda x: x == val
72     def is_fun(x):
73         return x == val
74     is_fun.__name__ = f"value_is_{val}"
75     return is_fun
76
77 def if_(v1,v2):
78     """if the second argument is v2, the first argument must be v1"""
79     #return lambda x1,x2: x1==v1 if x2==v2 else True
80     def if_fun(x1,x2):
81         return x1==v1 if x2==v2 else True
82     if_fun.__name__ = f"if x2 is {v2} then x1 is {v1}"
83     return if_fun
84
85 def eq_if_not_in_(actset):
86     """first and third arguments are equal if action is not in actset"""
87     # return lambda x1, a, x2: x1==x2 if a not in actset else True
88     def eq_if_not_fun(x1, a, x2):
89         return x1==x2 if a not in actset else True
90     eq_if_not_fun.__name__ = f"first and third arguments are equal if
91         action is not in {actset}"
92     return eq_if_not_fun

```

Putting it together, this returns a list of actions that solves the problem *prob* for a given horizon. If you want to do more than just return the list of actions, you might want to get it to return the solution. Or even enumerate the solutions (by using *Search.with.AC.from.CSP*).

```

stripsCSPPlanner.py — (continued)
93 def con_plan(prob,horizon):
94     """finds a plan for problem prob given horizon.
95     """
96     csp = CSP_from_STRIPS(prob, horizon)
97     sol = Con_solver(csp).solve_one()
98     return csp.extract_plan(sol) if sol else sol

```

The following are some example queries.

```

stripsCSPPlanner.py — (continued)

```

```

100 from searchGeneric import Searcher
101 from cspConsistency import Search_with_AC_from_CSP, Con_solver
102 from stripsProblem import Planning_problem
103 import stripsProblem
104
105 # Problem 0
106 # con_plan(stripsProblem.problem0,1) # should it succeed?
107 # con_plan(stripsProblem.problem0,2) # should it succeed?
108 # con_plan(stripsProblem.problem0,3) # should it succeed?
109 # To use search to enumerate solutions
110 #searcher0a =
111     Searcher(Search_with_AC_from_CSP(CSP_from_STRIPPS(stripsProblem.problem0,
112     1)))
111 #print(searcher0a.search()) # returns path to solution
112
113 ## Problem 1
114 # con_plan(stripsProblem.problem1,5) # should it succeed?
115 # con_plan(stripsProblem.problem1,4) # should it succeed?
116 ## To use search to enumerate solutions:
117 #searcher15a =
118     Searcher(Search_with_AC_from_CSP(CSP_from_STRIPPS(stripsProblem.problem1,
119     5)))
118 #print(searcher15a.search()) # returns path to solution
119
120 ## Problem 2
121 #con_plan(stripsProblem.problem2, 6) # should fail??
122 #con_plan(stripsProblem.problem2, 7) # should succeed???
123
124 ## Example 6.13
125 problem3 = Planning_problem(stripsProblem.delivery_domain,
126                             {'SWC':True, 'RHC':False}, {'SWC':False})
127 #con_plan(problem3,2) # Horizon of 2
128 #con_plan(problem3,3) # Horizon of 3
129
130 problem4 = Planning_problem(stripsProblem.delivery_domain,{'SWC':True},
131                             {'SWC':False, 'MW':False, 'RHM':False})
132
133 # For the stochastic local search:
134 #from cspSLS import SLSearcher, Runtime_distribution
135 # cspplanning15 = CSP_from_STRIPPS(stripsProblem.problem1, 5) # should
136     succeed
136 #se0 = SLSearcher(cspplanning15); print(se0.search(100000,0.5))
137 #p = Runtime_distribution(cspplanning15)
138 #p.plot_runs(1000,1000,0.7) # warning will take a few minutes

```

## 6.5 Partial-Order Planning

To run the demo, in folder "aipython", load "stripsPOP.py", and copy and paste the commented-out example queries at the bottom of that file.

A partial order planner maintains a partial order of action instances. An action instance consists of a name and an index. We need action instances because the same action could be carried out at different times.

```

-----stripsPOP.py — Partial-order Planner using STRIPS representation-----
11 from searchProblem import Arc, Search_problem
12 import random
13
14 class Action_instance(object):
15     next_index = 0
16     def __init__(self,action,index=None):
17         if index is None:
18             index = Action_instance.next_index
19             Action_instance.next_index += 1
20         self.action = action
21         self.index = index
22
23     def __str__(self):
24         return f"{self.action}#{self.index}"
25
26     __repr__ = __str__ # __repr__ function is the same as the __str__
                        function

```

A node (as in the abstraction of search space) in a partial-order planner consists of:

- *actions*: a set of action instances.
- *constraints*: a set of  $(a_1, a_2)$  pairs, where  $a_1$  and  $a_2$  are action instances, which represents that  $a_1$  must come before  $a_2$  in the partial order. There are a number of ways that this could be represented. Here we represent the set of pairs that are in transitive closure of the *before* relation. This lets us quickly determine whether some *before* relation is consistent with the current constraints.
- *agenda*: a list of  $(s, a)$  pairs, where  $s$  is a  $(var, val)$  pair and  $a$  is an action instance. This means that variable  $var$  must have value  $val$  before  $a$  can occur.
- *causal\_links*: a set of  $(a_0, g, a_1)$  triples, where  $a_1$  and  $a_2$  are action instances and  $g$  is a  $(var, val)$  pair. This holds when action  $a_0$  makes  $g$  true for action  $a_1$ .

```

stripsPOP.py — (continued)
28 class POP_node(object):
29     """a (partial) partial-order plan. This is a node in the search
        space."""
30     def __init__(self, actions, constraints, agenda, causal_links):
31         """
32         * actions is a set of action instances
33         * constraints a set of (a0,a1) pairs, representing a0<a1,
34           closed under transitivity
35         * agenda list of (subgoal,action) pairs to be achieved, where
36           subgoal is a (variable,value) pair
37         * causal_links is a set of (a0,g,a1) triples,
38           where ai are action instances, and g is a (variable,value) pair
39         """
40         self.actions = actions # a set of action instances
41         self.constraints = constraints # a set of (a0,a1) pairs
42         self.agenda = agenda # list of (subgoal,action) pairs to be
           achieved
43         self.causal_links = causal_links # set of (a0,g,a1) triples
44
45     def __str__(self):
46         return ("actions: "+str({str(a) for a in self.actions})+
47               "\nconstraints: "+
48               str({(str(a1),str(a2)) for (a1,a2) in self.constraints})+
49               "\nagenda: "+
50               str([(str(s),str(a)) for (s,a) in self.agenda])+
51               "\ncausal_links:"+
52               str({(str(a0),str(g),str(a2)) for (a0,g,a2) in
                    self.causal_links}) )

```

*extract\_plan* constructs a total order of action instances that is consistent with the partial order.

```

stripsPOP.py — (continued)
54 def extract_plan(self):
55     """returns a total ordering of the action instances consistent
56     with the constraints.
57     raises IndexError if there is no choice.
58     """
59     sorted_acts = []
60     other_acts = set(self.actions)
61     while other_acts:
62         a = random.choice([a for a in other_acts if
63                           all(((a1,a) not in self.constraints) for a1 in
                               other_acts)])
64         sorted_acts.append(a)
65         other_acts.remove(a)
66     return sorted_acts

```

*POP\_search\_from\_STRIPs* is an instance of a search problem. As such, we need to define the start nodes, the goal, and the neighbors of a node.

```

stripsPOP.py — (continued)
68 from display import Displayable
69
70 class POP_search_from_STRIPS(Search_problem, Displayable):
71     def __init__(self,planning_problem):
72         Search_problem.__init__(self)
73         self.planning_problem = planning_problem
74         self.start = Action_instance("start")
75         self.finish = Action_instance("finish")
76
77     def is_goal(self, node):
78         return node.agenda == []
79
80     def start_node(self):
81         constraints = {(self.start, self.finish)}
82         agenda = [(g, self.finish) for g in
83                 self.planning_problem.goal.items()]
84         return POP_node([self.start,self.finish], constraints, agenda, [] )

```

The *neighbors* method is a coroutine that enumerates the neighbors of a given node.

```

stripsPOP.py — (continued)
85 def neighbors(self, node):
86     """enumerates the neighbors of node"""
87     self.display(3,"finding neighbors of\n",node)
88     if node.agenda:
89         subgoal,act1 = node.agenda[0]
90         self.display(2,"selecting",subgoal,"for",act1)
91         new_agenda = node.agenda[1:]
92         for act0 in node.actions:
93             if (self.achieves(act0, subgoal) and
94                 self.possible((act0,act1),node.constraints)):
95                 self.display(2," reusing",act0)
96                 consts1 =
97                     self.add_constraint((act0,act1),node.constraints)
98                 new_clink = (act0,subgoal,act1)
99                 new_cls = node.causal_links + [new_clink]
100                for consts2 in
101                    self.protect_cl_for_actions(node.actions,consts1,new_clink):
102                    yield Arc(node,
103                               POP_node(node.actions,consts2,new_agenda,new_cls),
104                               cost=0)
103                for a0 in self.planning_problem.prob_domain.actions: #a0 is an
104                    action
105                    if self.achieves(a0, subgoal):
106                        #a0 acheieves subgoal
107                        new_a = Action_instance(a0)
108                        self.display(2," using new action",new_a)
109                        new_actions = node.actions + [new_a]

```

```

109         consts1 =
            self.add_constraint((self.start,new_a),node.constraints)
110         consts2 = self.add_constraint((new_a,act1),consts1)
111         new_agenda1 = new_agenda + [(pre,new_a) for pre in
            a0.preconds.items()]
112         new_clink = (new_a,subgoal,act1)
113         new_cls = node.causal_links + [new_clink]
114         for consts3 in
            self.protect_all_cls(node.causal_links,new_a,consts2):
115             for consts4 in
                self.protect_cl_for_actions(node.actions,consts3,new_clink):
116                 yield Arc(node,
117                     POP_node(new_actions,consts4,new_agenda1,new_cls),
118                     cost=1)

```

Given a causal link  $(a_0, subgoal, a_1)$ , the following method protects the causal link from each action in *actions*. Whenever an action deletes *subgoal*, the action needs to be before  $a_0$  or after  $a_1$ . This method enumerates all constraints that result from protecting the causal link from all actions.

```

stripsPOP.py — (continued)
120 def protect_cl_for_actions(self, actions, constra, clink):
121     """yields constraints that extend constra and
122     protect causal link (a0, subgoal, a1)
123     for each action in actions
124     """
125     if actions:
126         a = actions[0]
127         rem_actions = actions[1:]
128         a0, subgoal, a1 = clink
129         if a != a0 and a != a1 and self.deletes(a,subgoal):
130             if self.possible((a,a0),constra):
131                 new_const = self.add_constraint((a,a0),constra)
132                 for e in
                    self.protect_cl_for_actions(rem_actions,new_const,clink):
                    yield e # could be "yield from"
133             if self.possible((a1,a),constra):
134                 new_const = self.add_constraint((a1,a),constra)
135                 for e in
                    self.protect_cl_for_actions(rem_actions,new_const,clink):
                    yield e
136         else:
137             for e in
                self.protect_cl_for_actions(rem_actions,constra,clink):
                yield e
138     else:
139         yield constra

```

Given an action *act*, the following method protects all the causal links in *clinks* from *act*. Whenever *act* deletes *subgoal* from some causal link  $(a_0, subgoal, a_1)$ ,

the action *act* needs to be before *a0* or after *a1*. This method enumerates all constraints that result from protecting the causal links from *act*.

```

stripsPOP.py — (continued)
141 def protect_all_cls(self, clinks, act, constra):
142     """yields constraints that protect all causal links from act"""
143     if clinks:
144         (a0,cond,a1) = clinks[0] # select a causal link
145         rem_clinks = clinks[1:] # remaining causal links
146         if act != a0 and act != a1 and self.deletes(act,cond):
147             if self.possible((act,a0),constra):
148                 new_const = self.add_constraint((act,a0),constra)
149                 for e in self.protect_all_cls(rem_clinks,act,new_const):
150                     yield e
151             if self.possible((a1,act),constra):
152                 new_const = self.add_constraint((a1,act),constra)
153                 for e in self.protect_all_cls(rem_clinks,act,new_const):
154                     yield e
155         else:
156             for e in self.protect_all_cls(rem_clinks,act,constra): yield
157                 e
158     else:
159         yield constra

```

The following methods check whether an action (or action instance) achieves or deletes some subgoal.

```

stripsPOP.py — (continued)
158 def achieves(self,action,subgoal):
159     var,val = subgoal
160     return var in self.effects(action) and self.effects(action)[var] ==
161         val
162
163 def deletes(self,action,subgoal):
164     var,val = subgoal
165     return var in self.effects(action) and self.effects(action)[var] !=
166         val
167
168 def effects(self,action):
169     """returns the variable:value dictionary of the effects of action.
170     works for both actions and action instances"""
171     if isinstance(action, Action_instance):
172         action = action.action
173     if action == "start":
174         return self.planning_problem.initial_state
175     elif action == "finish":
176         return {}
177     else:
178         return action.effects

```

The constraints are represented as a set of pairs closed under transitivity. Thus if  $(a, b)$  and  $(b, c)$  are the list, then  $(a, c)$  must also be in the list. This means

that adding a new constraint means adding the implied pairs, but querying whether some order is consistent is quick.

```

stripsPOP.py — (continued)
178     def add_constraint(self, pair, const):
179         if pair in const:
180             return const
181         todo = [pair]
182         newconst = const.copy()
183         while todo:
184             x0,x1 = todo.pop()
185             newconst.add((x0,x1))
186             for x,y in newconst:
187                 if x==x1 and (x0,y) not in newconst:
188                     todo.append((x0,y))
189                 if y==x0 and (x,x1) not in newconst:
190                     todo.append((x,x1))
191         return newconst
192
193     def possible(self,pair,constraint):
194         (x,y) = pair
195         return (y,x) not in constraint

```

Some code for testing:

```

stripsPOP.py — (continued)
197 from searchBranchAndBound import DF_branch_and_bound
198 from searchMPP import SearcherMPP
199 import stripsProblem
200
201 rplanning0 = POP_search_from_STRIPS(stripsProblem.problem0)
202 rplanning1 = POP_search_from_STRIPS(stripsProblem.problem1)
203 rplanning2 = POP_search_from_STRIPS(stripsProblem.problem2)
204 searcher0 = DF_branch_and_bound(rplanning0,5)
205 searcher0a = SearcherMPP(rplanning0)
206 searcher1 = DF_branch_and_bound(rplanning1,10)
207 searcher1a = SearcherMPP(rplanning1)
208 searcher2 = DF_branch_and_bound(rplanning2,10)
209 searcher2a = SearcherMPP(rplanning2)
210 # Try one of the following searchers
211 # a = searcher0.search()
212 # a = searcher0a.search()
213 # a.end().extract_plan() # print a plan found
214 # a.end().constraints # print the constraints
215 # SearcherMPP.max_display_level = 0 # less detailed display
216 # DF_branch_and_bound.max_display_level = 0 # less detailed display
217 # a = searcher1.search()
218 # a = searcher1a.search()
219 # a = searcher2.search()
220 # a = searcher2a.search()

```



## Supervised Machine Learning

This chapter is the first on machine learning. It covers the following topics:

- Data: how to load it, training and test sets
- Features: many of the features come directly from the data. Sometimes it is useful to construct features, e.g.  $height > 1.9m$  might be a Boolean feature constructed from the real-values feature  $height$ . The next chapter is about neural networks and how to learn features; in this chapter we construct them explicitly in what is often known as **feature engineering**.
- Learning with no input features: this is the base case of many methods. What should we predict if we have no input features? This provides the base cases for many algorithms (e.g., decision tree algorithm) and baselines that more sophisticated algorithms need to beat. It also provides ways to test various predictors.
- Decision tree learning: one of the classic and simplest learning algorithms, which is the basis of many other algorithms.
- Cross validation and parameter tuning: methods to prevent overfitting.
- Linear regression and classification: other classic and simple techniques that often work well (particularly combined with feature learning or engineering).
- Boosting: combining simpler learning methods to make even better learners.

A good source of classic datasets is the UCI Machine Learning Repository [Lichman, 2013] [Dua and Graff, 2017]. The SPECT, IRIS, and car datasets (car-bool is a Boolean version of the car dataset) are from this repository.

Dataset	# Examples	#Columns	Input Types	Target Type
SPECT	267	23	Boolean	Boolean
IRIS	150	5	numeric	categorical
carbool	1728	7	categorical/numeric	numeric
holiday	32	6	Boolean	Boolean
mail_reading	28	5	Boolean	Boolean
tv_likes	12	5	Boolean	Boolean
simp_regr	7	2	numeric	numeric

Figure 7.1: Some of the datasets used here.

## 7.1 Representations of Data and Predictions

The code uses the following definitions and conventions:

- A **dataset** is an enumeration of examples.
- An **example** is a list (or tuple) of values. The values can be numbers or strings.
- A **feature** is a function from examples into the range of the feature. Each feature  $f$  also has the following attributes:

$f.f\text{type}$ , the type of  $f$ , one of: "boolean", "categorical", "numeric"

$f.f\text{range}$ , the set of values of  $f$  seen in the dataset, represented as a list.

The  $f\text{type}$  is inferred from the  $f\text{range}$  if not given explicitly.

$f.\_\text{doc}\_\_\_$ , the docstring, a string description of  $f$  (for printing).

Thus for example, a **Boolean feature** is a function from the examples into  $\{False, True\}$ . So, if  $f$  is a Boolean feature,  $f.f\text{range} == [False, True]$ , and if  $e$  is an example,  $f(e)$  is either *True* or *False*.

learnProblem.py — A Learning Problem

```

11 import math, random, statistics
12 import csv
13 from display import Displayable
14 from utilities import argmax
15
16 boolean = [False, True]
```

When creating a dataset, we partition the data into a training set (*train*) and a test set (*test*). The target feature is the feature that we are making a prediction of. A dataset  $ds$  has the following attributes

$ds.train$  a list of the training examples

$ds.test$  a list of the test examples

`ds.target_index` the index of the target

`ds.target` the feature corresponding to the target (a function as described above)

`ds.input_features` a list of the input features

learnProblem.py — (continued)

```

18 class Data_set(Displayable):
19     """ A dataset consists of a list of training data and a list of test
20         data.
21     """
22     def __init__(self, train, test=None, prob_test=0.20, target_index=0,
23                 header=None, target_type=None, seed=None): #12345):
24         """A dataset for learning.
25         train is a list of tuples representing the training examples
26         test is the list of tuples representing the test examples
27         if test is None, a test set is created by selecting each
28         example with probability prob_test
29         target_index is the index of the target.
30         If negative, it counts from right.
31         If target_index is larger than the number of properties,
32         there is no target (for unsupervised learning)
33         header is a list of names for the features
34         target_type is either None for automatic detection of target type
35         or one of "numeric", "boolean", "categorical"
36         seed is for random number; None gives a different test set each time
37         """
38         if seed: # given seed makes partition consistent from run-to-run
39             random.seed(seed)
40         if test is None:
41             train,test = partition_data(train, prob_test)
42         self.train = train
43         self.test = test
44
45         self.display(1,"Training set has",len(train),"examples. Number of
46                     columns: ",{len(e) for e in train})
47         self.display(1,"Test set has",len(test),"examples. Number of
48                     columns: ",{len(e) for e in test})
49         self.prob_test = prob_test
50         self.num_properties = len(self.train[0])
51         if target_index < 0: #allows for -1, -2, etc.
52             self.target_index = self.num_properties + target_index
53         else:
54             self.target_index = target_index
55         self.header = header
56         self.domains = [set() for i in range(self.num_properties)]
57         for example in self.train:
58             for ind,val in enumerate(example):

```

```

57         self.domains[ind].add(val)
58     self.conditions_cache = {} # cache for computed conditions
59     self.create_features()
60     if target_type:
61         self.target.ftype = target_type
62     self.display(1, "There are", len(self.input_features), "input
        features")
63
64     def __str__(self):
65         if self.train and len(self.train)>0:
66             return ("Data: "+str(len(self.train))+ " training examples, "
67                     +str(len(self.test))+ " test examples, "
68                     +str(len(self.train[0]))+ " features.")
69         else:
70             return ("Data: "+str(len(self.train))+ " training examples, "
71                     +str(len(self.test))+ " test examples.")

```

A **feature** is a function that takes an example and returns a value in the range of the feature. Each feature has a **frange**, which gives the range of the feature, and an **ftype** that gives the type, one of "boolean", "numeric" or "categorical".

---

```

learnProblem.py — (continued)
73     def create_features(self):
74         """create the set of features
75         """
76         self.target = None
77         self.input_features = []
78         for i in range(self.num_properties):
79             def feat(e, index=i):
80                 return e[index]
81             if self.header:
82                 feat.__doc__ = self.header[i]
83             else:
84                 feat.__doc__ = "e["+str(i)+"]"
85             feat.frange = list(self.domains[i])
86             feat.ftype = self.infer_type(feat.frange)
87             if i == self.target_index:
88                 self.target = feat
89             else:
90                 self.input_features.append(feat)

```

We try to infer the type of each feature. Sometimes this can be wrong, (e.g., when the numbers are really categorical) and may need to be set explicitly.

---

```

learnProblem.py — (continued)
92     def infer_type(self, domain):
93         """Infers the type of a feature with domain
94         """
95         if all(v in {True, False} for v in domain):
96             return "boolean"

```

```

97     if all(isinstance(v,(float,int)) for v in domain):
98         return "numeric"
99     else:
100        return "categorical"

```

### 7.1.1 Creating Boolean Conditions from Features

Some of the algorithms require Boolean input features or features with range  $\{0,1\}$ . In order to be able to use these algorithms on datasets that allow for arbitrary domains of input variables, we construct Boolean conditions from the attributes.

There are 3 cases:

- When the range only has two values, we designate one to be the “true” value.
- When the values are all numeric, we assume they are ordered (as opposed to just being some classes that happen to be labelled with numbers) and construct Boolean features for splits of the data. That is, the feature is  $e[ind] < cut$  for some value  $cut$ . We choose a number of  $cut$  values, up to a maximum number of cuts, given by  $max\_num\_cuts$ .
- When the values are not all numeric, we create an indicator function for each value. An indicator function for a value returns true when that value is given and false otherwise. Note that we can’t create an indicator function for values that appear in the test set but not in the training set because we haven’t seen the test set. For the examples in the test set with a value that doesn’t appear in the training set for that feature, the indicator functions all return false.

There is also an option `categorical_only` to create only Boolean features for categorical input features, and not to make cuts for numerical values.

```

learnProblem.py — (continued)
102     def conditions(self, max_num_cuts=8, categorical_only = False):
103         """returns a set of boolean conditions from the input features
104         max_num_cuts is the maximum number of cuts for numeric features
105         categorical_only is true if only categorical features are made
           binary
106         """
107         if (max_num_cuts, categorical_only) in self.conditions_cache:
108             return self.conditions_cache[(max_num_cuts, categorical_only)]
109         conds = []
110         for ind,frange in enumerate(self.domains):
111             if ind != self.target_index and len(frange)>1:
112                 if len(frange) == 2:
113                     # two values, the feature is equality to one of them.
114                     true_val = list(frange)[1] # choose one as true

```

```

115     def feat(e, i=ind, tv=true_val):
116         return e[i]==tv
117     if self.header:
118         feat.__doc__ = f"{self.header[ind]}=={true_val}"
119     else:
120         feat.__doc__ = f"e[{ind]}=={true_val}"
121     feat.frange = boolean
122     feat.ftype = "boolean"
123     conds.append(feat)
124     elif all(isinstance(val,(int,float)) for val in frange):
125         if categorical_only: # numeric, don't make cuts
126             def feat(e, i=ind):
127                 return e[i]
128                 feat.__doc__ = f"e[{ind}]"
129                 conds.append(feat)
130         else:
131             # all numeric, create cuts of the data
132             sorted_frange = sorted(frange)
133             num_cuts = min(max_num_cuts,len(frange))
134             cut_positions = [len(frange)*i//num_cuts for i in
135                             range(1,num_cuts)]
136             for cut in cut_positions:
137                 cutat = sorted_frange[cut]
138                 def feat(e, ind_=ind, cutat=cutat):
139                     return e[ind_] < cutat
140
141                 if self.header:
142                     feat.__doc__ = self.header[ind]+"<" +str(cutat)
143                 else:
144                     feat.__doc__ = "e["+str(ind)+"<" +str(cutat)
145                 feat.frange = boolean
146                 feat.ftype = "boolean"
147                 conds.append(feat)
148         else:
149             # create an indicator function for every value
150             for val in frange:
151                 def feat(e, ind_=ind, val_=val):
152                     return e[ind_] == val_
153                 if self.header:
154                     feat.__doc__ = self.header[ind]+"==" +str(val)
155                 else:
156                     feat.__doc__ = "e["+str(ind)+"==" +str(val)
157                 feat.frange = boolean
158                 feat.ftype = "boolean"
159                 conds.append(feat)
160     self.conditions_cache[(max_num_cuts, categorical_only)] = conds
161     return conds

```

**Exercise 7.1** Change the code so that it splits using  $e[ind] \leq cut$  instead of  $e[ind] < cut$ . Check boundary cases, such as 3 elements with 2 cuts. As a test case, make sure that when the range is the 30 integers from 100 to 129, and you want 2 cuts,

the resulting Boolean features should be  $e[ind] \leq 109$  and  $e[ind] \leq 119$  to make sure that each of the resulting domains is of equal size.

**Exercise 7.2** This splits on whether the feature is less than one of the values in the training set. Sam suggested it might be better to split between the values in the training set, and suggested using

$$cutat = (sorted\_frange[cut] + sorted\_frange[cut - 1])/2$$

Why might Sam have suggested this? Does this work better? (Try it on a few datasets).

### 7.1.2 Evaluating Predictions

A **predictor** is a function that takes an example and makes a prediction on the values of the target features.

A **loss** takes a prediction and the actual value and returns a non-negative real number; lower is better. The **error** for a dataset is either the mean loss, or sometimes the sum of the losses. When reporting results the mean is usually used. When it is the sum, this will be made explicit.

The function *evaluate\_dataset* returns the average error for each example, where the error for each example depends on the evaluation criteria. Here we consider three evaluation criteria, the squared error (average of the square of the difference between the actual and predicted values), absolute errors (average of the absolute difference between the actual and predicted values) and the log loss (the average negative log-likelihood, which can be interpreted as the number of bits to describe an example using a code based on the prediction treated as a probability).

```

learnProblem.py — (continued)
162     def evaluate_dataset(self, data, predictor, error_measure):
163         """Evaluates predictor on data according to the error_measure
164         predictor is a function that takes an example and returns a
165         prediction for the target features.
166         error_measure(prediction,actual) -> non-negative real
167         """
168         if data:
169             try:
170                 value = statistics.mean(error_measure(predictor(e),
171                                                     self.target(e))
172                                       for e in data)
173             except ValueError: # if error_measure gives an error
174                 return float("inf") # infinity
175             return value
176         else:
177             return math.nan # not a number

```

The following evaluation criteria are defined. This is defined using a class, Evaluate but no instances will be created. Just use Evaluate.squared\_loss etc.

(Please keep the `__doc__` strings a consistent length as they are used in tables.)  
 The prediction is either a real value or a `{value : probability}` dictionary or a list.  
 The actual is either a real number or a key of the prediction.

```

learnProblem.py — (continued)
178 class Evaluate(object):
179     """A container for the evaluation measures"""
180
181     def squared_loss(prediction, actual):
182         "squared loss "
183         if isinstance(prediction, (list,dict)):
184             return (1-prediction[actual])**2 # the correct value is 1
185         else:
186             return (prediction-actual)**2
187
188     def absolute_loss(prediction, actual):
189         "absolute loss "
190         if isinstance(prediction, (list,dict)):
191             return abs(1-prediction[actual]) # the correct value is 1
192         else:
193             return abs(prediction-actual)
194
195     def log_loss(prediction, actual):
196         "log loss (bits)"
197         try:
198             if isinstance(prediction, (list,dict)):
199                 return -math.log2(prediction[actual])
200             else:
201                 return -math.log2(prediction) if actual==1 else
202                     -math.log2(1-prediction)
203         except ValueError:
204             return float("inf") # infinity
205
206     def accuracy(prediction, actual):
207         "accuracy "
208         if isinstance(prediction, dict):
209             prev_val = prediction[actual]
210             return 1 if all(prev_val >= v for v in prediction.values())
211                 else 0
212         if isinstance(prediction, list):
213             prev_val = prediction[actual]
214             return 1 if all(prev_val >= v for v in prediction) else 0
215         else:
216             return 1 if abs(actual-prediction) <= 0.5 else 0
217
218     all_criteria = [accuracy, absolute_loss, squared_loss, log_loss]

```

### 7.1.3 Creating Test and Training Sets

The following method partitions the data into a training set and a test set. Note that this does not guarantee that the test set will contain exactly a proportion of the data equal to *prob\_test*.

[An alternative is to use *random.sample()* which can guarantee that the test set will contain exactly a particular proportion of the data. However this would require knowing how many elements are in the dataset, which we may not know, as *data* may just be a generator of the data (e.g., when reading the data from a file).]

```

learnProblem.py — (continued)
218 def partition_data(data, prob_test=0.30):
219     """partitions the data into a training set and a test set, where
220     prob_test is the probability of each example being in the test set.
221     """
222     train = []
223     test = []
224     for example in data:
225         if random.random() < prob_test:
226             test.append(example)
227         else:
228             train.append(example)
229     return train, test

```

### 7.1.4 Importing Data From File

A dataset is typically loaded from a file. The default here is that it loaded from a CSV (comma separated values) file, although the separator can be changed. This assumes that all lines that contain the separator are valid data (so we only include those data items that contain more than one element). This allows for blank lines and comment lines that do not contain the separator. However, it means that this method is not suitable for cases where there is only one feature.

Note that *data\_all* and *data\_tuples* are generators. *data\_all* is a generator of a list of list of strings. This version assumes that CSV files are simple. The standard *csv* package, that allows quoted arguments, can be used by uncommenting the line for *data\_all* and commenting out the following line. *data\_tuples* contains only those lines that contain the delimiter (others lines are assumed to be empty or comments), and tries to convert the elements to numbers whenever possible.

This allows for some of the columns to be included; specified by *include\_only*. Note that if *include\_only* is specified, the target index is the index for the included columns, not the original columns.

```

learnProblem.py — (continued)
231 class Data_from_file(Data_set):
232     def __init__(self, file_name, separator=',', num_train=None,
                prob_test=0.3,

```

```

233         has_header=False, target_index=0, boolean_features=True,
234         categorical=[], target_type=None, include_only=None,
                seed=None): #seed=12345):
235     """create a dataset from a file
236     separator is the character that separates the attributes
237     num_train is a number specifying the first num_train tuples are
                training, or None
238     prob_test is the probability an example should in the test set (if
                num_train is None)
239     has_header is True if the first line of file is a header
240     target_index specifies which feature is the target
241     boolean_features specifies whether we want to create Boolean
                features
242         (if False, it uses the original features).
243     categorical is a set (or list) of features that should be treated
                as categorical
244     target_type is either None for automatic detection of target type
245         or one of "numeric", "boolean", "categorical"
246     include_only is a list or set of indexes of columns to include
247     """
248     self.boolean_features = boolean_features
249     with open(file_name, 'r', newline='') as csvfile:
250         self.display(1, "Loading", file_name)
251         # data_all = csv.reader(csvfile, delimiter=separator) # for more
                complicated CSV files
252         data_all = (line.strip().split(separator) for line in csvfile)
253         if include_only is not None:
254             data_all = ([v for (i,v) in enumerate(line) if i in
                include_only]
                for line in data_all)
255         if has_header:
256             header = next(data_all)
257         else:
258             header = None
259         data_tuples = (interpret_elements(d) for d in data_all if
                len(d)>1)
260         if num_train is not None:
261             # training set is divided into training then test examples
262             # the file is only read once, and the data is placed in
                appropriate list
263             train = []
264             for i in range(num_train): # will give an error if
                insufficient examples
265                 train.append(next(data_tuples))
266             test = list(data_tuples)
267             Data_set.__init__(self, train, test=test,
                target_index=target_index, header=header)
268         else: # randomly assign training and test examples
269             Data_set.__init__(self, data_tuples, test=None,
270                 prob_test=prob_test,

```

```

271 |                                     target_index=target_index, header=header,
|                                     seed=seed, target_type=target_type)

```

The following class is used for datasets where the training and test are in different files

```

----- learnProblem.py --- (continued) -----
273 class Data_from_files(Data_set):
274     def __init__(self, train_file_name, test_file_name, separator=',',
275                 has_header=False, target_index=0, boolean_features=True,
276                 categorical=[], target_type= None, include_only=None):
277         """create a dataset from separate training and file
278         separator is the character that separates the attributes
279         num_train is a number specifying the first num_train tuples are
           training, or None
280         prob_test is the probability an example should in the test set (if
           num_train is None)
281         has_header is True if the first line of file is a header
282         target_index specifies which feature is the target
283         boolean_features specifies whether we want to create Boolean
           features
284         (if False, it uses the original features).
285         categorical is a set (or list) of features that should be treated
           as categorical
286         target_type is either None for automatic detection of target type
287         or one of "numeric", "boolean", "categorical"
288         include_only is a list or set of indexes of columns to include
289         """
290         self.boolean_features = boolean_features
291         with open(train_file_name,'r',newline='') as train_file:
292             with open(test_file_name,'r',newline='') as test_file:
293                 # data_all = csv.reader(csvfile,delimiter=separator) # for more
           complicated CSV files
294                 train_data = (line.strip().split(separator) for line in
           train_file)
295                 test_data = (line.strip().split(separator) for line in
           test_file)
296                 if include_only is not None:
297                     train_data = ([v for (i,v) in enumerate(line) if i in
           include_only]
298                                 for line in train_data)
299                     test_data = ([v for (i,v) in enumerate(line) if i in
           include_only]
300                                 for line in test_data)
301                 if has_header: # this assumes the training file has a header
           and the test file doesn't
302                     header = next(train_data)
303                 else:
304                     header = None
305                 train_tuples = [interpret_elements(d) for d in train_data if
           len(d)>1]

```

```

306         test_tuples = [interpret_elements(d) for d in test_data if
307                         len(d)>1]
308         Data_set.__init__(self,train_tuples, test_tuples,
                           target_index=target_index, header=header)

```

When reading from a file all of the values are strings. This next method tries to convert each value into a number (an int or a float) or Boolean, if it is possible.

```

_____learnProblem.py — (continued)_____
310 def interpret_elements(str_list):
311     """make the elements of string list str_list numeric if possible.
312     Otherwise remove initial and trailing spaces.
313     """
314     res = []
315     for e in str_list:
316         try:
317             res.append(int(e))
318         except ValueError:
319             try:
320                 res.append(float(e))
321             except ValueError:
322                 se = e.strip()
323                 if se in ["True", "true", "TRUE"]:
324                     res.append(True)
325                 elif se in ["False", "false", "FALSE"]:
326                     res.append(False)
327                 else:
328                     res.append(e.strip())
329     return res

```

### 7.1.5 Augmented Features

Sometimes we want to augment the features with new features computed from the old features (e.g., the product of features). Here we allow the creation of a new dataset from an old dataset but with new features. Note that special cases of these are **kernels**; mapping the original feature space into a new space, which allow a neat way to do learning in the augmented space for many mappings (the “kernel trick”). This is beyond the scope of AIPython; those interested should read about support vector machines.

A feature is a function of examples. A unary feature constructor takes a feature and returns a new feature. A binary feature combiner takes two features and returns a new feature.

```

_____learnProblem.py — (continued)_____
331 class Data_set_augmented(Data_set):
332     def __init__(self, dataset, unary_functions=[], binary_functions=[],
333                 include_orig=True):
334         """creates a dataset like dataset but with new features

```

```

334     unary_function is a list of unary feature constructors
335     binary_functions is a list of binary feature combiners.
336     include_orig specifies whether the original features should be
           included
337     """
338     self.orig_dataset = dataset
339     self.unary_functions = unary_functions
340     self.binary_functions = binary_functions
341     self.include_orig = include_orig
342     self.target = dataset.target
343     Data_set.__init__(self, dataset.train, test=dataset.test,
344                      target_index = dataset.target_index)
345
346     def create_features(self):
347         if self.include_orig:
348             self.input_features = self.orig_dataset.input_features.copy()
349         else:
350             self.input_features = []
351         for u in self.unary_functions:
352             for f in self.orig_dataset.input_features:
353                 self.input_features.append(u(f))
354         for b in self.binary_functions:
355             for f1 in self.orig_dataset.input_features:
356                 for f2 in self.orig_dataset.input_features:
357                     if f1 != f2:
358                         self.input_features.append(b(f1, f2))

```

The following are useful unary feature constructors and binary feature combiner.

```

learnProblem.py — (continued)
360 def square(f):
361     """a unary feature constructor to construct the square of a feature
362     """
363     def sq(e):
364         return f(e)**2
365     sq.__doc__ = f.__doc__+"**2"
366     return sq
367
368 def power_feat(n):
369     """given n returns a unary feature constructor to construct the nth
370     power of a feature.
371     e.g., power_feat(2) is the same as square, defined above
372     """
373     def fn(f, n=n):
374         def pow(e, n=n):
375             return f(e)**n
376         pow.__doc__ = f.__doc__+"**"+str(n)
377         return pow
378     return fn

```

```

379 def prod_feat(f1,f2):
380     """a new feature that is the product of features f1 and f2
381     """
382     def feat(e):
383         return f1(e)*f2(e)
384     feat.__doc__ = f1.__doc__+"*" +f2.__doc__
385     return feat
386
387 def eq_feat(f1,f2):
388     """a new feature that is 1 if f1 and f2 give same value
389     """
390     def feat(e):
391         return 1 if f1(e)==f2(e) else 0
392     feat.__doc__ = f1.__doc__+"==" +f2.__doc__
393     return feat
394
395 def neq_feat(f1,f2):
396     """a new feature that is 1 if f1 and f2 give different values
397     """
398     def feat(e):
399         return 1 if f1(e)!=f2(e) else 0
400     feat.__doc__ = f1.__doc__+"!=" +f2.__doc__
401     return feat

```

Example:

```

learnProblem.py — (continued)
403 # from learnProblem import Data_set_augmented,prod_feat
404 # data = Data_from_file('data/holiday.csv', has_header=True, num_train=19,
405     target_index=-1)
406 # data = Data_from_file('data/iris.data', prob_test=1/3, target_index=-1)
407 ## Data = Data_from_file('data/SPECT.csv', prob_test=0.5, target_index=0)
408 # dataplus = Data_set_augmented(data,[],[prod_feat])
409 # dataplus = Data_set_augmented(data,[],[prod_feat,neq_feat])

```

**Exercise 7.3** For symmetric properties, such as product, we don't need both  $f1 * f2$  as well as  $f2 * f1$  as extra properties. Allow the user to be able to declare feature constructors as symmetric (by associating a Boolean feature with them). Change *construct\_features* so that it does not create both versions for symmetric combiners.

## 7.2 Generic Learner Interface

A **learner** takes a dataset (and possibly other arguments specific to the method). To get it to learn, we call the *learn()* method. This implements *Displayable* so that we can display traces at multiple levels of detail (perhaps with a GUI).

```

learnProblem.py — (continued)
409 from display import Displayable

```

```

410
411 class Learner(Displayable):
412     def __init__(self, dataset):
413         raise NotImplementedError("Learner.__init__") # abstract method
414
415     def learn(self):
416         """returns a predictor, a function from a tuple to a value for the
417         target feature
418         """
419         raise NotImplementedError("learn") # abstract method

```

## 7.3 Learning With No Input Features

If we make the same prediction for each example, what prediction should we make? This can be used as a naive baseline; if a more sophisticated method does not do better than this, it is not useful. This also provides the base case for some methods, such as decision-tree learning.

To run demo to compare different prediction methods on various evaluation criteria, in folder "aipython", load "learnNoInputs.py", using e.g., `ipython -i learnNoInputs.py`, and it prints some test results.

There are a few alternatives as to what could be allowed in a prediction:

- a point prediction, where we are only allowed to predict one of the values of the feature. For example, if the values of the feature are  $\{0, 1\}$  we are only allowed to predict 0 or 1 or of the values are ratings in  $\{1, 2, 3, 4, 5\}$ , we can only predict one of these integers.
- a point prediction, where we are allowed to predict any value. For example, if the values of the feature are  $\{0, 1\}$  we may be allowed to predict 0.3, 1, or even 1.7. For all of the criteria we can imagine, there is no point in predicting a value greater than 1 or less than zero (but that doesn't mean we can't), but it is often useful to predict a value between 0 and 1. If the values are ratings in  $\{1, 2, 3, 4, 5\}$ , we may want to predict 3.4.
- a probability distribution over the values of the feature. For each value  $v$ , we predict a non-negative number  $p_v$ , such that the sum over all predictions is 1.

For regression, we do the first of these. For classification, we do the second. The third can be implemented by having multiple indicator functions for the target.

Here are some prediction functions that take in an enumeration of values, a domain, and returns a value or dictionary of  $\{value : prediction\}$ . Note that `median` returns one of the middle values when there are an even number of

examples, whereas median gives the average of them (and so `cmedian` is applicable for ordinals that cannot be considered cardinal values). Similarly, `cmode` picks one of the values when more than one value has the maximum number of elements.

```

learnNoInputs.py — Learning ignoring all input features
11 from learnProblem import Evaluate
12 import math, random, collections, statistics
13 import utilities # argmax for (element,value) pairs
14
15 class Predict(object):
16     """The class of prediction methods for a list of values.
17     Please make the doc strings the same length, because they are used in
18     tables.
19     Note that we don't need self argument, as we are creating Predict
20     objects,
21     To use call Predict.laplace(data) etc."""
22
23     ### The following return a distribution over values (for classification)
24     def empirical(data, domain=[0,1], icount=0):
25         "empirical dist "
26         # returns a distribution over values
27         counts = {v:icount for v in domain}
28         for e in data:
29             counts[e] += 1
30         s = sum(counts.values())
31         return {k:v/s for (k,v) in counts.items()}
32
33     def bounded_empirical(data, domain=[0,1], bound=0.01):
34         "bounded empirical"
35         return {k:min(max(v,bound),1-bound) for (k,v) in
36                 Predict.empirical(data, domain).items()}
37
38     def laplace(data, domain=[0,1]):
39         "Laplace " # for categorical data
40         return Predict.empirical(data, domain, icount=1)
41
42     def cmode(data, domain=[0,1]):
43         "mode " # for categorical data
44         md = statistics.mode(data)
45         return {v: 1 if v==md else 0 for v in domain}
46
47     def cmedian(data, domain=[0,1]):
48         "median " # for categorical data
49         md = statistics.median_low(data) # always return one of the values
50         return {v: 1 if v==md else 0 for v in domain}
51
52     ### The following return a single prediction (for regression). domain
53     is ignored.

```

```

51 def mean(data, domain=[0,1]):
52     "mean          "
53     # returns a real number
54     return statistics.mean(data)
55
56 def rmean(data, domain=[0,1], mean0=0, pseudo_count=1):
57     "regularized mean"
58     # returns a real number.
59     # mean0 is the mean to be used for 0 data points
60     # With mean0=0.5, pseudo_count=2, same as laplace for [0,1] data
61     # this works for enumerations as well as lists
62     sum = mean0 * pseudo_count
63     count = pseudo_count
64     for e in data:
65         sum += e
66         count += 1
67     return sum/count
68
69 def mode(data, domain=[0,1]):
70     "mode          "
71     return statistics.mode(data)
72
73 def median(data, domain=[0,1]):
74     "median        "
75     return statistics.median(data)
76
77 all = [empirical, mean, rmean, bounded_empirical, laplace, cmode, mode,
78        median, cmedian]
79
80 # The following suggests appropriate predictions as a function of the
81 # target type
82 select = {"boolean": [empirical, bounded_empirical, laplace, cmode,
83                      cmedian],
84          "categorical": [empirical, bounded_empirical, laplace, cmode,
85                          cmedian],
86          "numeric": [mean, rmean, mode, median]}

```

### 7.3.1 Evaluation

To evaluate a point prediction, we first generate some data from a simple (Bernoulli) distribution, where there are two possible values, 0 and 1 for the target feature. Given *prob*, a number in the range  $[0, 1]$ , this generate some training and test data where *prob* is the probability of each example being 1. To generate a 1 with probability *prob*, we generate a random number in range  $[0, 1]$  and return 1 if that number is less than *prob*. A prediction is computed by applying the predictor to the training data, which is evaluated on the test set. This is repeated `num_samples` times.

Let's evaluate the predictions of the possible selections according to the different evaluation criteria, for various training sizes.

```

learnNoInputs.py — (continued)
83 def test_no_inputs(error_measures = Evaluate.all_criteria,
84                   num_samples=10000,
85                   test_size=10, training_sizes=
86                       [1,2,3,4,5,10,20,100,1000]):
87     for train_size in training_sizes:
88         results = {predictor: {error_measure: 0 for error_measure in
89                               error_measures}
90                   for predictor in Predict.all}
91         for sample in range(num_samples):
92             prob = random.random()
93             training = [1 if random.random()<prob else 0 for i in
94                         range(train_size)]
95             test = [1 if random.random()<prob else 0 for i in
96                    range(test_size)]
97             for predictor in Predict.all:
98                 prediction = predictor(training)
99                 for error_measure in error_measures:
100                     results[predictor][error_measure] += sum(
101                         error_measure(prediction,actual) for actual in
102                         test)/test_size
103         print(f"For training size {train_size}:")
104         print(" Predictor\t", "\t".join(error_measure.__doc__ for
105                                         error_measure in
106                                         error_measures), sep="\t")
107         for predictor in Predict.all:
108             print(f" {predictor.__doc__}",
109                   "\t".join("{:.7f}".format(results[predictor][error_measure]/num_samples)
110                               for error_measure in
111                               error_measures), sep="\t")
112
113 if __name__ == "__main__":
114     test_no_inputs()

```

**Exercise 7.4** Which predictor works best for low counts when the error is

- (a) Squared error
- (b) Absolute error
- (c) Log loss

You may need to try this a few times to make sure your answer is supported by the evidence. Does the difference from the other methods get more or less as the number of examples grow?

**Exercise 7.5** Suggest some other predictors that only take the training data. Does your method do better than the given methods? A simple way to get other predictors is to vary the threshold of bounded average, or to change the pseudo-counts of the Laplace method (use other numbers instead of 1 and 2).

## 7.4 Decision Tree Learning

To run the decision tree learning demo, in folder "aipython", load "learnDT.py", using e.g., `ipython -i learnDT.py`, and it prints some test results. To try more examples, copy and paste the commented-out commands at the bottom of that file. This requires Python 3 with matplotlib.

The decision tree algorithm does binary splits, and assumes that all input features are binary functions of the examples. It stops splitting if there are no input features, the number of examples is less than a specified number of examples or all of the examples agree on the target feature.

```

learnDT.py — Learning a binary decision tree
11 from learnProblem import Learner, Evaluate
12 from learnNoInputs import Predict
13 import math
14
15 class DT_learner(Learner):
16     def __init__(self,
17                 dataset,
18                 split_to_optimize=Evaluate.log_loss, # to minimize for at
19                 each split
20                 leaf_prediction=Predict.empirical, # what to use for value
21                 at leaves
22                 train=None, # used for cross validation
23                 max_num_cuts=8, # maximum number of conditions to split a
24                 numeric feature into
25                 gamma=1e-7, # minimum improvement needed to expand a node
26                 min_child_weight=10):
27         self.dataset = dataset
28         self.target = dataset.target
29         self.split_to_optimize = split_to_optimize
30         self.leaf_prediction = leaf_prediction
31         self.max_num_cuts = max_num_cuts
32         self.gamma = gamma
33         self.min_child_weight = min_child_weight
34         if train is None:
35             self.train = self.dataset.train
36         else:
37             self.train = train
38
39     def learn(self, max_num_cuts=8):
40         """learn a decision tree"""
41         return self.learn_tree(self.dataset.conditions(self.max_num_cuts),
42                               self.train)

```

The main recursive algorithm, takes in a set of input features and a set of training data. It first decides whether to split. If it doesn't split, it makes a point prediction, ignoring the input features.

It only splits if the best split increases the error by at least  $\gamma$ . This implies it does not split when:

- there are no more input features
- there are fewer examples than *min\_number\_examples*,
- all the examples agree on the value of the target, or
- the best split puts all examples in the same partition.

If it splits, it selects the best split according to the evaluation criterion (assuming that is the only split it gets to do), and returns the condition to split on (in the variable *split*) and the corresponding partition of the examples.

```

learnDT.py — (continued)
40 def learn_tree(self, conditions, data_subset):
41     """returns a decision tree
42     conditions is a set of possible conditions
43     data_subset is a subset of the data used to build this (sub)tree
44
45     where a decision tree is a function that takes an example and
46     makes a prediction on the target feature
47     """
48     self.display(2,f"learn_tree with {len(conditions)} features and
49                 {len(data_subset)} examples")
50     split, partn = self.select_split(conditions, data_subset)
51     if split is None: # no split; return a point prediction
52         prediction = self.leaf_value(data_subset, self.target.frange)
53         self.display(2,f"leaf prediction for {len(data_subset)}
54                     examples is {prediction}")
55         def leaf_fun(e):
56             return prediction
57         leaf_fun.__doc__ = str(prediction)
58         leaf_fun.num_leaves = 1
59         return leaf_fun
60     else: # a split succeeded
61         false_examples, true_examples = partn
62         rem_features = [fe for fe in conditions if fe != split]
63         self.display(2,"Splitting on",split.__doc__,"with examples
64                     split",
65                     len(true_examples),":",len(false_examples))
66         true_tree = self.learn_tree(rem_features,true_examples)
67         false_tree = self.learn_tree(rem_features,false_examples)
68         def fun(e):
69             if split(e):
70                 return true_tree(e)
71             else:
72                 return false_tree(e)
73         #fun = lambda e: true_tree(e) if split(e) else false_tree(e)
74         fun.__doc__ = (f"(if {split.__doc__} then {true_tree.__doc__}")

```

```

72         f" else {false_tree.__doc__}")
73     fun.num_leaves = true_tree.num_leaves + false_tree.num_leaves
74     return fun

```

---

```

learnDT.py -- (continued)
76     def leaf_value(self, egs, domain):
77         return self.leaf_prediction((self.target(e) for e in egs), domain)
78
79     def select_split(self, conditions, data_subset):
80         """finds best feature to split on.
81
82         conditions is a non-empty list of features.
83         returns feature, partition
84         where feature is an input feature with the smallest error as
85             judged by split_to_optimize or
86             feature==None if there are no splits that improve the error
87         partition is a pair (false_examples, true_examples) if feature is
88             not None
89         """
90         best_feat = None # best feature
91         # best_error = float("inf") # infinity - more than any error
92         best_error = self.sum_losses(data_subset) - self.gamma
93         self.display(3, " no split has
94             error=",best_error,"with",len(conditions),"conditions")
95         best_partition = None
96         for feat in conditions:
97             false_examples, true_examples = partition(data_subset,feat)
98             if
99                 min(len(false_examples),len(true_examples))>=self.min_child_weight:
100                 err = (self.sum_losses(false_examples)
101                     + self.sum_losses(true_examples))
102                 self.display(3, " split on",feat.__doc__,"has error=",err,
103                     "splits
104                     into",len(true_examples),":",len(false_examples),"gamma=",self.gamma)
105                 if err < best_error:
106                     best_feat = feat
107                     best_error=err
108                     best_partition = false_examples, true_examples
109                 self.display(2,"best split is on",best_feat.__doc__,
110                     "with err=",best_error)
111         return best_feat, best_partition
112
113     def sum_losses(self, data_subset):
114         """returns sum of losses for dataset (with no more splits)
115         There a single prediction for all leaves using leaf_prediction
116         It is evaluated using split_to_optimize
117         """
118         prediction = self.leaf_value(data_subset, self.target.frange)
119         error = sum(self.split_to_optimize(prediction, self.target(e))
120             for e in data_subset)

```

```

117         return error
118
119     def partition(data_subset, feature):
120         """partitions the data_subset by the feature"""
121         true_examples = []
122         false_examples = []
123         for example in data_subset:
124             if feature(example):
125                 true_examples.append(example)
126             else:
127                 false_examples.append(example)
128         return false_examples, true_examples

```

Test cases:

```

learnDT.py -- (continued)
131 from learnProblem import Data_set, Data_from_file
132
133 def testDT(data, print_tree=True, selections = None, **tree_args):
134     """Prints errors and the trees for various evaluation criteria and ways
135     to select leaves.
136     """
137     if selections == None: # use selections suitable for target type
138         selections = Predict.select[data.target.ftype]
139     evaluation_criteria = Evaluate.all_criteria
140     print("Split Choice", "Leaf Choice\t", "#leaves", '\t'.join(ecrit.__doc__
141         for ecrit in
142         evaluation_criteria), sep="\t")
143
144     for crit in evaluation_criteria:
145         for leaf in selections:
146             tree = DT_learner(data, split_to_optimize=crit,
147                 leaf_prediction=leaf,
148                 **tree_args).learn()
149             print(crit.__doc__, leaf.__doc__, tree.num_leaves,
150                 "\t".join("{:.7f}".format(data.evaluate_dataset(data.test,
151                     tree, ecrit))
152                     for ecrit in evaluation_criteria), sep="\t")
153
154         if print_tree:
155             print(tree.__doc__)
156
157 #DT_learner.max_display_level = 4
158 if __name__ == "__main__":
159     # Choose one of the data files
160     #data=Data_from_file('data/SPECT.csv', target_index=0);
161     print("SPECT.csv")
162     #data=Data_from_file('data/iris.data', target_index=-1);
163     print("iris.data")
164     data = Data_from_file('data/carbool.csv', target_index=-1, seed=123)
165     #data = Data_from_file('data/mail_reading.csv', target_index=-1);
166     print("mail_reading.csv")

```

```

158 | #data = Data_from_file('data/holiday.csv', has_header=True,
      |         num_train=19, target_index=-1); print("holiday.csv")
159 | testDT(data, print_tree=False)

```

Note that different runs may provide different values as they split the training and test sets differently. So if you have a hypothesis about what works better, make sure it is true for different runs.

**Exercise 7.6** The current algorithm does not have a very sophisticated stopping criterion. What is the current stopping criterion? (Hint: you need to look at both *learn\_tree* and *select\_split*.)

**Exercise 7.7** Extend the current algorithm to include in the stopping criterion

- (a) A minimum child size; don't use a split if one of the children has fewer elements than this.
- (b) A depth-bound on the depth of the tree.
- (c) An improvement bound such that a split is only carried out if error with the split is better than the error without the split by at least the improvement bound.

Which values for these parameters make the prediction errors on the test set the smallest? Try it on more than one dataset.

**Exercise 7.8** Without any input features, it is often better to include a pseudo-count that is added to the counts from the training data. Modify the code so that it includes a pseudo-count for the predictions. When evaluating a split, including pseudo counts can make the split worse than no split. Does pruning with an improvement bound and pseudo-counts make the algorithm work better than with an improvement bound by itself?

**Exercise 7.9** Some people have suggested using information gain (which is equivalent to greedy optimization of log loss) as the measure of improvement when building the tree, even in they want to have non-probabilistic predictions in the final tree. Does this work better than myopically choosing the split that is best for the evaluation criteria we will use to judge the final prediction?

## 7.5 Cross Validation and Parameter Tuning

To run the cross validation demo, in folder "aipython", load "learnCrossValidation.py", using e.g., `ipython -i learnCrossValidation.py`. Run the examples at the end to produce a graph like Figure 7.15. Note that different runs will produce different graphs, so your graph will not look like the one in the textbook. To try more examples, copy and paste the commented-out commands at the bottom of that file. This requires Python 3 with `matplotlib`.

The above decision tree overfits the data. One way to determine whether the prediction is overfitting is by cross validation. The code below implements  $k$ -fold cross validation, which can be used to choose the value of parameters to best fit the training data. If we want to use parameter tuning to improve predictions on a particular dataset, we can only use the training data (and not the test data) to tune the parameter.

In  $k$ -fold cross validation, we partition the training set into  $k$  approximately equal-sized folds (each fold is an enumeration of examples). For each fold, we train on the other examples, and determine the error of the prediction on that fold. For example, if there are 10 folds, we train on 90% of the data, and then test on remaining 10% of the data. We do this 10 times, so that each example gets used as a test set once, and in the training set 9 times.

The code below creates one copy of the data, and multiple views of the data. For each fold, *fold* enumerates the examples in the fold, and *fold\_complement* enumerates the examples not in the fold.

```

learnCrossValidation.py — Cross Validation for Parameter Tuning
11 from learnProblem import Data_set, Data_from_file, Evaluate
12 from learnNoInputs import Predict
13 from learnDT import DT_learner
14 import matplotlib.pyplot as plt
15 import random
16
17 class K_fold_dataset(object):
18     def __init__(self, training_set, num_folds):
19         self.data = training_set.train.copy()
20         self.target = training_set.target
21         self.input_features = training_set.input_features
22         self.num_folds = num_folds
23         self.conditions = training_set.conditions
24
25         random.shuffle(self.data)
26         self.fold_boundaries = [(len(self.data)*i)//num_folds
27                                for i in range(0,num_folds+1)]
28
29     def fold(self, fold_num):
30         for i in range(self.fold_boundaries[fold_num],
31                       self.fold_boundaries[fold_num+1]):
32             yield self.data[i]
33
34     def fold_complement(self, fold_num):
35         for i in range(0,self.fold_boundaries[fold_num]):
36             yield self.data[i]
37         for i in range(self.fold_boundaries[fold_num+1],len(self.data)):
38             yield self.data[i]

```

The validation error is the average error for each example, where we test on each fold, and learn on the other folds.

```

learnCrossValidation.py — (continued)

```

```

40 def validation_error(self, learner, error_measure, **other_params):
41     error = 0
42     try:
43         for i in range(self.num_folds):
44             predictor = learner(self,
45                                 train=list(self.fold_complement(i)),
46                                 **other_params).learn()
47             error += sum( error_measure(predictor(e), self.target(e))
48                           for e in self.fold(i))
49     except ValueError:
50         return float("inf") #infinity
51     return error/len(self.data)

```

The `plot_error` method plots the average error as a function of the minimum number of examples in decision-tree search, both for the validation set and for the test set. The error on the validation set can be used to tune the parameter — choose the value of the parameter that minimizes the error. The error on the test set cannot be used to tune the parameters; if it were to be used this way it could not be used to test how well the method works on unseen examples.

```

learnCrossValidation.py — (continued)
52 def plot_error(data, criterion=Evaluate.squared_loss,
53               leaf_prediction=Predict.empirical,
54               num_folds=5, maxx=None, xscale='linear'):
55     """Plots the error on the validation set and the test set
56     with respect to settings of the minimum number of examples.
57     xscale should be 'log' or 'linear'
58     """
59     plt.ion()
60     plt.xscale(xscale) # change between log and linear scale
61     plt.xlabel("min_child_weight")
62     plt.ylabel("average "+criterion.__doc__)
63     folded_data = K_fold_dataset(data, num_folds)
64     if maxx == None:
65         maxx = len(data.train)//2+1
66     verrors = [] # validation errors
67     terrors = [] # test set errors
68     for mcw in range(1,maxx):
69         verrors.append(folded_data.validation_error(DT_learner,criterion,leaf_prediction=leaf_pred,
70                                                    min_child_weight=mcw))
71         tree = DT_learner(data, criterion, leaf_prediction=leaf_prediction,
72                           min_child_weight=mcw).learn()
73         terrors.append(data.evaluate_dataset(data.test,tree,criterion))
74     plt.plot(range(1,maxx), verrors, ls='-',color='k',
75             label="validation for "+criterion.__doc__)
76     plt.plot(range(1,maxx), terrors, ls='--',color='k',
77             label="test set for "+criterion.__doc__)
78     plt.legend()
79     plt.draw()

```

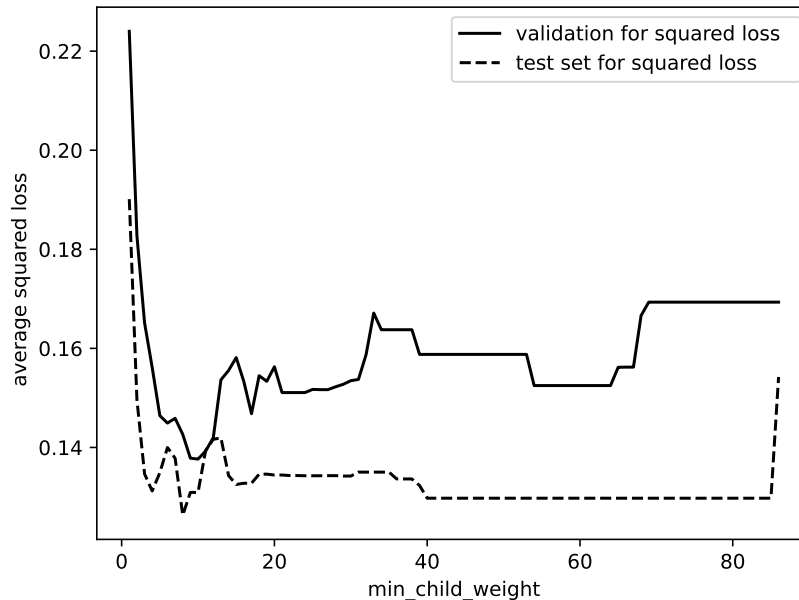

Figure 7.2: plot\_error for SPECT dataset

```

79 # The following produces the graphs of Figure 7.18 of Poole and Mackworth
    [2023]
80 # data = Data_from_file('data/SPECT.csv', target_index=0, seed=123)
81 # plot_error(data, criterion=Evaluate.log_loss,
    leaf_prediction=Predict.laplace)
82
83 #also try:
84 # plot_error(data)
85 # data = Data_from_file('data/carbool.csv', target_index=-1, seed=123)

```

Figure 7.2 shows the average squared loss in the validation and test sets as a function of the `min_child_weight` in the decision-tree learning algorithm. (SPECT data with seed 12345 followed by `plot_error(data)`). Different seeds will produce different graphs. The assumption behind cross validation is that the parameter that minimizes the loss on the validation set, will be a good parameter for the test set.

Note that different runs for the same data will have the same test error, but different validation error. If you rerun the `Data_from_file`, with a different seed, you will get the new test and training sets, and so the graph will change.

**Exercise 7.10** Change the error plot so that it can evaluate the stopping criteria of the exercise of Section 7.6. Which criteria makes the most difference?

## 7.6 Linear Regression and Classification

Here is a stochastic gradient descent searcher for linear regression and classification.

```

learnLinear.py — Linear Regression and Classification
11 from learnProblem import Learner
12 import random, math
13
14 class Linear_learner(Learner):
15     def __init__(self, dataset, train=None,
16                 learning_rate=0.1, max_init = 0.2,
17                 squashed=True, batch_size=10):
18         """Creates a gradient descent searcher for a linear classifier.
19         The main learning is carried out by learn()
20
21         dataset provides the target and the input features
22         train provides a subset of the training data to use
23         number_iterations is the default number of steps of gradient descent
24         learning_rate is the gradient descent step size
25         max_init is the maximum absolute value of the initial weights
26         squashed specifies whether the output is a squashed linear function
27         """
28         self.dataset = dataset
29         self.target = dataset.target
30         if train==None:
31             self.train = self.dataset.train
32         else:
33             self.train = train
34         self.learning_rate = learning_rate
35         self.squashed = squashed
36         self.batch_size = batch_size
37         self.input_features = [one]+dataset.input_features # one is defined
38                                     below
39         self.weights = {feat:random.uniform(-max_init,max_init)
40                         for feat in self.input_features}

```

*predictor* predicts the value of an example from the current parameter settings.  
*predictor\_string* gives a string representation of the predictor.

```

learnLinear.py — (continued)
41
42 def predictor(self,e):
43     """returns the prediction of the learner on example e"""
44     linpred = sum(w*f(e) for f,w in self.weights.items())
45     if self.squashed:
46         return sigmoid(linpred)
47     else:
48         return linpred
49
50 def predictor_string(self, sig_dig=3):

```

```

51     """returns the doc string for the current prediction function
52     sig_dig is the number of significant digits in the numbers"""
53     doc = "+".join(str(round(val,sig_dig))+"*"+feat.__doc__
54                     for feat,val in self.weights.items())
55     if self.squashed:
56         return "sigmoid("+ doc+")"
57     else:
58         return doc

```

*learn* is the main algorithm of the learner. It does *num\_iter* steps of stochastic gradient descent. Only the number of iterations is specified; the other parameters it gets from the class.

```

-----learnLinear.py --- (continued) -----
60     def learn(self,num_iter=100):
61         batch_size = min(self.batch_size, len(self.train))
62         d = {feat:0 for feat in self.weights}
63         for it in range(num_iter):
64             self.display(2,"prediction=",self.predictor_string())
65             for e in random.sample(self.train, batch_size):
66                 error = self.predictor(e) - self.target(e)
67                 update = self.learning_rate*error
68                 for feat in self.weights:
69                     d[feat] += update*feat(e)
70             for feat in self.weights:
71                 self.weights[feat] -= d[feat]
72                 d[feat]=0
73         return self.predictor

```

*one* is a function that always returns 1. This is used for one of the input properties.

```

-----learnLinear.py --- (continued) -----
75     def one(e):
76         "1"
77         return 1

```

*sigmoid(x)* is the function

$$\frac{1}{1 + e^{-x}}$$

The inverse of *sigmoid* is the *logit* function

```

-----learnLinear.py --- (continued) -----
79     def sigmoid(x):
80         return 1/(1+math.exp(-x))
81
82     def logit(x):
83         return -math.log(1/x-1)

```

$\text{sigmoid}([x_0, v_2, \dots])$  returns  $[v_0, v_2, \dots]$  where

$$v_i = \frac{\exp(x_i)}{\sum_j \exp(x_j)}$$

The inverse of *sigmoid* is the *logit* function

```

learnLinear.py — (continued)
85 def softmax(xs, domain=None):
86     """xs is a list of values, and
87     domain is the domain (a list) or None if the list should be returned
88     returns a distribution over the domain (a dict)
89     """
90     m = max(xs) # use of m prevents overflow (and all values underflowing)
91     exps = [math.exp(x-m) for x in xs]
92     s = sum(exps)
93     if domain:
94         return {d:v/s for (d,v) in zip(domain,exp)}
95     else:
96         return [v/s for v in exps]
97
98 def indicator(v, domain):
99     return [1 if v==dv else 0 for dv in domain]

```

The following tests the learner on a datasets. Uncomment the other datasets for different examples.

```

learnLinear.py — (continued)
101 from learnProblem import Data_set, Data_from_file, Evaluate
102 from learnProblem import Evaluate
103 import matplotlib.pyplot as plt
104
105 def test(**args):
106     data = Data_from_file('data/SPECT.csv', target_index=0)
107     # data = Data_from_file('data/mail_reading.csv', target_index=-1)
108     # data = Data_from_file('data/carbool.csv', target_index=-1)
109     learner = Linear_learner(data,**args)
110     learner.learn()
111     print("function learned is", learner.predictor_string())
112     for ecrit in Evaluate.all_criteria:
113         test_error = data.evaluate_dataset(data.test, learner.predictor,
114         ecrit)
114     print(" Average", ecrit.__doc__, "is", test_error)

```

The following plots the errors on the training and test sets as a function of the number of steps of gradient descent.

```

learnLinear.py — (continued)
116 def plot_steps(learner=None,
117               data = None,
118               criterion=Evaluate.squared_loss,

```

```

119         step=1,
120         num_steps=1000,
121         log_scale=True,
122         legend_label=""):
123     """
124     plots the training and test error for a learner.
125     data is the
126     learner_class is the class of the learning algorithm
127     criterion gives the evaluation criterion plotted on the y-axis
128     step specifies how many steps are run for each point on the plot
129     num_steps is the number of points to plot
130
131     """
132     if legend_label != "": legend_label+=" "
133     plt.ion()
134     plt.xlabel("step")
135     plt.ylabel("Average "+criterion.__doc__)
136     if log_scale:
137         plt.xscale('log') #plt.semilogx() #Makes a log scale
138     else:
139         plt.xscale('linear')
140     if data is None:
141         data = Data_from_file('data/holiday.csv', has_header=True,
142                               num_train=19, target_index=-1)
143         #data = Data_from_file('data/SPECT.csv', target_index=0)
144         # data = Data_from_file('data/mail_reading.csv', target_index=-1)
145         # data = Data_from_file('data/carbool.csv', target_index=-1)
146     #random.seed(None) # reset seed
147     if learner is None:
148         learner = Linear_learner(data)
149     train_errors = []
150     test_errors = []
151     for i in range(1,num_steps+1,step):
152         test_errors.append(data.evaluate_dataset(data.test,
153                                                  learner.predictor, criterion))
154         train_errors.append(data.evaluate_dataset(data.train,
155                                                  learner.predictor, criterion))
156         learner.display(2, "Train error:",train_errors[-1],
157                        "Test error:",test_errors[-1])
158         learner.learn(num_iter=step)
159     plt.plot(range(1,num_steps+1,step),train_errors,ls='-',label=legend_label+"training")
160     plt.plot(range(1,num_steps+1,step),test_errors,ls='--',label=legend_label+"test")
161     plt.legend()
162     plt.draw()
163     learner.display(1, "Train error:",train_errors[-1],
164                   "Test error:",test_errors[-1])
165
166 if __name__ == "__main__":
167     test()

```

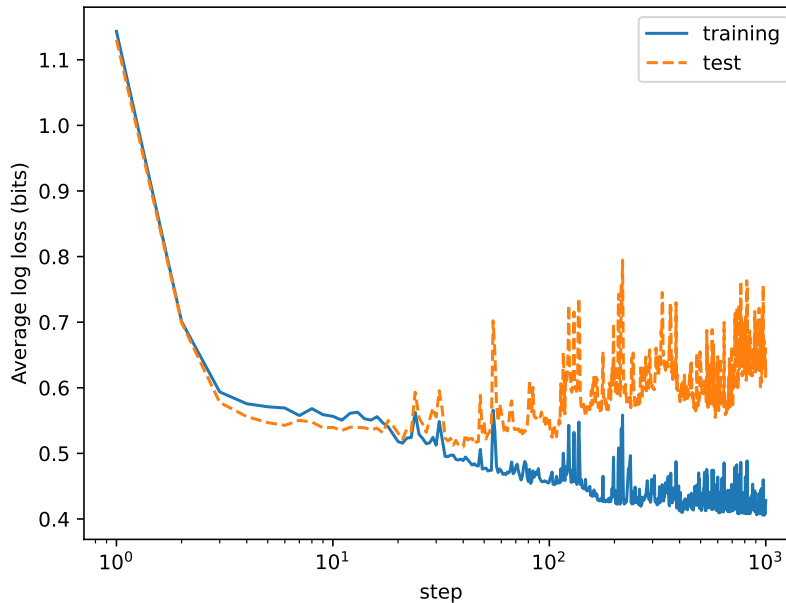

Figure 7.3: plot\_steps for SPECT dataset

```

166 # This generates the figure
167 # from learnProblem import Data_set_augmented, prod_feat
168 # data = Data_from_file('data/SPECT.csv', prob_test=0.5, target_index=0,
169 #                       seed=123)
169 # dataplus = Data_set_augmented(data, [], [prod_feat])
170 # plot_steps(data=data, num_steps=1000)
171 # plot_steps(data=dataplus, num_steps=1000) # warning very slow

```

Figure 7.3 shows the result of `plot_steps(data=data, num_steps=1000)` in the code above. What would you expect to happen with the augmented data (with extra features)? Hint: think about underfitting and overfitting.

**Exercise 7.11** The squashed learner only makes predictions in the range  $(0, 1)$ . If the output values are  $\{1, 2, 3, 4\}$  there is no use predicting less than 1 or greater than 4. Change the squashed learner so that it can learn values in the range  $(1, 4)$ . Test it on the file 'data/car.csv'.

The following plots the prediction as a function of the number of steps of gradient descent. We first define a version of `range` that allows for real numbers (integers and floats).

```

learnLinear.py — (continued)
172 def arange(start, stop, step):
173     """returns enumeration of values in the range [start, stop) separated by
    step.

```

```

174     like the built-in range(start,stop,step) but allows for integers and
        floats.
175     Note that rounding errors are expected with real numbers. (or use
        numpy.arange)
176     """
177     while start<stop:
178         yield start
179         start += step
180
181     def plot_prediction(data,
182                       learner = None,
183                       minx = 0,
184                       maxx = 5,
185                       step_size = 0.01, # for plotting
186                       label = "function"):
187         plt.ion()
188         plt.xlabel("x")
189         plt.ylabel("y")
190         if learner is None:
191             learner = Linear_learner(data, squashed=False)
192         learner.learning_rate=0.001
193         learner.learn(100)
194         learner.learning_rate=0.0001
195         learner.learn(1000)
196         learner.learning_rate=0.00001
197         learner.learn(10000)
198         learner.display(1,"function learned is", learner.predictor_string(),
199                       "error=",data.evaluate_dataset(data.train, learner.predictor,
200                                                       Evaluate.squared_loss))
201         plt.plot([e[0] for e in data.train],[e[-1] for e in
202                data.train],"bo",label="data")
203         plt.plot(list(arange(minx,maxx,step_size)),[learner.predictor([x])
204                for x in
205                    arange(minx,maxx,step_size)],
206                label=label)
207
208         plt.legend()
209         plt.draw()

```

---

learnLinear.py — (continued)

---

```

207     from learnProblem import Data_set_augmented, power_feat
208     def plot_polynomials(data,
209                       learner_class = Linear_learner,
210                       max_degree = 5,
211                       minx = 0,
212                       maxx = 5,
213                       num_iter = 1000000,
214                       learning_rate = 0.00001,
215                       step_size = 0.01, # for plotting
216                       ):
217         plt.ion()

```

```

218 plt.xlabel("x")
219 plt.ylabel("y")
220 plt.plot([e[0] for e in data.train],[e[-1] for e in
221         data.train],"ko",label="data")
222 x_values = list(arange(minx,maxx,step_size))
223 line_styles = ['-','--','-.',':']
224 colors = ['0.5','k','k','k','k']
225 for degree in range(max_degree):
226     data_aug = Data_set_augmented(data,[power_feat(n) for n in
227         range(1,degree+1)],
228         include_orig=False)
229     learner = learner_class(data_aug,squashed=False)
230     learner.learning_rate = learning_rate
231     learner.learn(num_iter)
232     learner.display(1,"For degree",degree,
233         "function learned is", learner.predictor_string(),
234         "error=",data.evaluate_dataset(data.train,
235         learner.predictor, Evaluate.squared_loss))
236     ls = line_styles[degree % len(line_styles)]
237     col = colors[degree % len(colors)]
238     plt.plot(x_values,[learner.predictor([x]) for x in x_values],
239         linestyle=ls, color=col,
240         label="degree="+str(degree))
241     plt.legend(loc='upper left')
242     plt.draw()
243
244 # Try:
245 # data0 = Data_from_file('data/simp_regr.csv', prob_test=0,
246     boolean_features=False, target_index=-1)
247 # plot_prediction(data0)
248 # plot_polynomials(data0)
249 # What if the step size was bigger?
250 #datam = Data_from_file('data/mail_reading.csv', target_index=-1)
251 #plot_prediction(datam)

```

## 7.7 Boosting

The following code implements functional gradient boosting for regression.

A Boosted dataset is created from a base dataset by subtracting the prediction of the offset function from each example. This does not save the new dataset, but generates it as needed. The amount of space used is constant, independent on the size of the dataset.

```

_____learnBoosting.py — Functional Gradient Boosting_____
11 from learnProblem import Data_set, Learner, Evaluate
12 from learnNoInputs import Predict
13 from learnLinear import sigmoid
14 import statistics
15 import random

```

```

16
17 class Boosted_dataset(Data_set):
18     def __init__(self, base_dataset, offset_fun, subsample=1.0):
19         """new dataset which is like base_dataset,
20         but offset_fun(e) is subtracted from the target of each example e
21         """
22         self.base_dataset = base_dataset
23         self.offset_fun = offset_fun
24         self.train =
25             random.sample(base_dataset.train, int(subsample*len(base_dataset.train)))
26         self.test = base_dataset.test
27         #Data_set.__init__(self, base_dataset.train, base_dataset.test,
28         #                    base_dataset.prob_test, base_dataset.target_index)
29
30     def create_features(self):
31         """creates new features - called at end of Data_set.init()
32         defines a new target
33         """
34         self.input_features = self.base_dataset.input_features
35         def newout(e):
36             return self.base_dataset.target(e) - self.offset_fun(e)
37         newout.frange = self.base_dataset.target.frange
38         newout.ftype = self.infer_type(newout.frange)
39         self.target = newout
40
41     def conditions(self, *args, colsample_bytree=0.5, **nargs):
42         conds = self.base_dataset.conditions(*args, **nargs)
43         return random.sample(conds, int(colsample_bytree*len(conds)))

```

A boosting learner takes in a dataset and a base learner, and returns a new predictor. The base learner, takes a dataset, and returns a Learner object.

learnBoosting.py — (continued)

```

44 class Boosting_learner(Learner):
45     def __init__(self, dataset, base_learner_class, subsample=0.8):
46         self.dataset = dataset
47         self.base_learner_class = base_learner_class
48         self.subsample = subsample
49         mean = sum(self.dataset.target(e)
50                 for e in self.dataset.train)/len(self.dataset.train)
51         self.predictor = lambda e:mean # function that returns mean for
52             each example
53         self.predictor.__doc__ = "lambda e:"+str(mean)
54         self.offsets = [self.predictor] # list of base learners
55         self.predictors = [self.predictor] # list of predictors
56         self.errors = [data.evaluate_dataset(data.test, self.predictor,
57             Evaluate.squared_loss)]
58         self.display(1,"Predict mean test set mean squared loss=",
59             self.errors[0] )

```

```

59     def learn(self, num_ensembles=10):
60         """adds num_ensemble learners to the ensemble.
61         returns a new predictor.
62         """
63         for i in range(num_ensembles):
64             train_subset = Boosted_dataset(self.dataset, self.predictor,
65                 subsample=self.subsample)
66             learner = self.base_learner_class(train_subset)
67             new_offset = learner.learn()
68             self.offsets.append(new_offset)
69             def new_pred(e, old_pred=self.predictor, off=new_offset):
70                 return old_pred(e)+off(e)
71             self.predictor = new_pred
72             self.predictors.append(new_pred)
73             self.errors.append(data.evaluate_dataset(data.test,
74                 self.predictor, Evaluate.squared_loss))
75             self.display(1, f"Iteration {len(self.offsets)-1}, treesize =
76                 {new_offset.num_leaves}. mean squared
77                 loss={self.errors[-1]}")
78         return self.predictor

```

For testing, *sp\_DT\_learner* returns a learner that predicts the mean at the leaves and is evaluated using squared loss. It can also take arguments to change the default arguments for the trees.

learnBoosting.py — (continued)

```

76 # Testing
77
78 from learnDT import DT_learner
79 from learnProblem import Data_set, Data_from_file
80
81 def sp_DT_learner(split_to_optimize=Evaluate.squared_loss,
82                 leaf_prediction=Predict.mean,**nargs):
83     """Creates a learner with different default arguments replaced by
84     **nargs
85     """
86     def new_learner(dataset):
87         return DT_learner(dataset,split_to_optimize=split_to_optimize,
88                             leaf_prediction=leaf_prediction, **nargs)
89     return new_learner
90
91 #data = Data_from_file('data/car.csv', target_index=-1) regression
92 data = Data_from_file('data/student/student-mat-nq.csv',
93     separator=';', has_header=True, target_index=-1, seed=13, include_only=list(range(30))+[32])
94     #2.0537973790924946
95 #data = Data_from_file('data/SPECT.csv', target_index=0, seed=62) #123)
96 #data = Data_from_file('data/mail_reading.csv', target_index=-1)
97 #data = Data_from_file('data/holiday.csv', has_header=True, num_train=19,
98     target_index=-1)
99 #learner10 = Boosting_learner(data,
100     sp_DT_learner(split_to_optimize=Evaluate.squared_loss,

```

```

    leaf_prediction=Predict.mean, min_child_weight=10))
96 #learner7 = Boosting_learner(data, sp_DT_learner(0.7))
97 #learner5 = Boosting_learner(data, sp_DT_learner(0.5))
98 #predictor9 =learner9.learn(10)
99 #for i in learner9.offsets: print(i.__doc__)
100 import matplotlib.pyplot as plt
101
102 def plot_boosting_trees(data, steps=10, mcws=[30,20,20,10], gammas=
    [100,200,300,500]):
103     # to reduce clutter uncomment one of following two lines
104     #mcws=[10]
105     #gammas=[200]
106     learners = [(mcw, gamma, Boosting_learner(data,
        sp_DT_learner(min_child_weight=mcw, gamma=gamma)))
107                 for gamma in gammas for mcw in mcws
108                 ]
109     plt.ion()
110     plt.xscale('linear') # change between log and linear scale
111     plt.xlabel("number of trees")
112     plt.ylabel("mean squared loss")
113     markers = (m+c for c in ['k','g','r','b','m','c','y'] for m in
        ['-','--','-.-',':'])
114     for (mcw,gamma,learner) in learners:
115         data.display(1,f"min_child_weight={mcw}, gamma={gamma}")
116         learner.learn(steps)
117         plt.plot(range(steps+1), learner.errors, next(markers),
118                 label=f"min_child_weight={mcw}, gamma={gamma}")
119     plt.legend()
120     plt.draw()
121
122 # plot_boosting_trees(data)

```

### 7.7.1 Gradient Tree Boosting

The following implements gradient Boosted trees for classification. If you want to use this gradient tree boosting for a real problem, we recommend using **XGBoost** [Chen and Guestrin, 2016] or **LightGBM** [Ke, Meng, Finley, Wang, Chen, Ma, Ye, and Liu, 2017].

GTB\_learner subclasses DT\_learner. The method learn\_tree is used unchanged. DT\_learner assumes that the value at the leaf is the prediction of the leaf, thus leaf\_value needs to be overridden. It also assumes that all nodes at a leaf have the same prediction, but in GBT the elements of a leaf can have different values, depending on the previous trees. Thus sum\_losses also needs to be overridden.

```

learnBoosting.py — (continued)
124 class GTB_learner(DT_learner):
125     def __init__(self, dataset, number_trees, lambda_reg=1, gamma=0,
        **dtargs):

```

```

126     DT_learner.__init__(self, dataset,
127         split_to_optimize=Evaluate.log_loss, **dtargs)
128     self.number_trees = number_trees
129     self.lambda_reg = lambda_reg
130     self.gamma = gamma
131     self.trees = []
132
133     def learn(self):
134         for i in range(self.number_trees):
135             tree =
136                 self.learn_tree(self.dataset.conditions(self.max_num_cuts),
137                     self.train)
138             self.trees.append(tree)
139             self.display(1, f"""Iteration {i} treesize = {tree.num_leaves}
140                 train logloss={
141                     self.dataset.evaluate_dataset(self.dataset.train,
142                         self.gtb_predictor, Evaluate.log_loss)
143                 } test logloss={
144                     self.dataset.evaluate_dataset(self.dataset.test,
145                         self.gtb_predictor, Evaluate.log_loss)}""")
146         return self.gtb_predictor
147
148     def gtb_predictor(self, example, extra=0):
149         """prediction for example,
150         extras is an extra contribution for this example being considered
151         """
152         return sigmoid(sum(t(example) for t in self.trees)+extra)
153
154     def leaf_value(self, egs, domain=[0,1]):
155         """value at the leaves for examples egs
156         domain argument is ignored"""
157         predActs = [(self.gtb_predictor(e),self.target(e)) for e in egs]
158         return sum(a-p for (p,a) in predActs) / (sum(p*(1-p) for (p,a) in
159             predActs)+self.lambda_reg)
160
161     def sum_losses(self, data_subset):
162         """returns sum of losses for dataset (assuming a leaf is formed
163         with no more splits)
164         """
165         leaf_val = self.leaf_value(data_subset)
166         error = sum(Evaluate.log_loss(self.gtb_predictor(e,leaf_val),
167             self.target(e))
168             for e in data_subset) + self.gamma
169         return error

```

## Testing

---

```

163 # data = Data_from_file('data/carbool.csv', target_index=-1, seed=123)
164 # gtb_learner = GTB_learner(data, 10)

```

```
165 | # gtb_learner.learn()
```

## Neural Networks and Deep Learning

Warning: this is not meant to be an efficient implementation of deep learning. If you want to do serious machine learning on medium-sized or large data, we recommend Keras (<https://keras.io>) [Chollet, 2021] or PyTorch (<https://pytorch.org>), which are very efficient, particularly on GPUs. They are, however, black boxes. The AIPython neural network code should be seen like a car engine made of glass; you can see exactly how it works, even if it is not fast.

The parameters that are the same as in Keras have the same names. In AIPython, activation functions are treated as separate layers, which makes them more modular and readable.

### 8.1 Layers

A neural network is built from layers.

This provides a modular implementation of layers. Layers can easily be stacked in many configurations. A layer needs to implement a function to compute the output values from the inputs, a way to back-propagate the error, and perhaps update its parameters.

```
learnNN.py — Neural Network Learning
11 from learnProblem import Learner, Data_set, Data_from_file,
    Data_from_files, Evaluate
12 from learnLinear import sigmoid, one, softmax, indicator
13 import random, math, time
14
15 class Layer(object):
16     def __init__(self, nn, num_outputs=None):
```

```

17     """Given a list of inputs, outputs will produce a list of length
18         num_outputs.
19     nn is the neural network this layer is part of
20     num_outputs is the number of outputs for this layer.
21     """
22     self.nn = nn
23     self.num_inputs = nn.num_outputs # output of nn is the input to
24         this layer
25     if num_outputs:
26         self.num_outputs = num_outputs
27     else:
28         self.num_outputs = nn.num_outputs # same as the inputs
29
30     def output_values(self, input_values, training=False):
31         """Return the outputs for this layer for the given input values.
32         input_values is a list of the inputs to this layer (of length
33             num_inputs)
34         returns a list of length self.num_outputs.
35         It can act differently when training and when predicting.
36         """
37         raise NotImplementedError("output_values") # abstract method
38
39     def backprop(self, errors):
40         """Backpropagate the errors on the outputs
41         errors is a list of errors for the outputs (of length
42             self.num_outputs).
43         Returns the errors for the inputs to this layer (of length
44             self.num_inputs).
45
46         You can assume that this is only called after corresponding
47             output_values,
48             which can remember information information required for the
49             back-propagation.
50         """
51         raise NotImplementedError("backprop") # abstract method
52
53     def update(self):
54         """updates parameters after a batch.
55         overridden by layers that have parameters
56         """
57         pass

```

### 8.1.1 Linear Layer

A linear layer maintains an array of weights.  $self.weights[o][i]$  is the weight between input  $i$  and output  $o$ . A 1 is added to the end of the inputs. The default initialization is the Glorot uniform initializer [Glorot and Bengio, 2010], which is the default in Keras. An alternative is to provide a limit, in which case the

values are selected uniformly in the range  $[-limit, limit]$ . Keras treats the bias separately, and by default initializes to zero.

```

learnNN.py — (continued)
52 class Linear_complete_layer(Layer):
53     """a completely connected layer"""
54     def __init__(self, nn, num_outputs, limit=None):
55         """A completely connected linear layer.
56         nn is a neural network that the inputs come from
57         num_outputs is the number of outputs
58         the random initialization of parameters is in range [-limit,limit]
59         """
60         Layer.__init__(self, nn, num_outputs)
61         if limit is None:
62             limit =math.sqrt(6/(self.num_inputs+self.num_outputs))
63         # self.weights[o][i] is the weight between input i and output o
64         self.weights = [[random.uniform(-limit, limit) if inf <
65                         self.num_inputs else 0
66                         for inf in range(self.num_inputs+1)]
67                         for outf in range(self.num_outputs)]
68         self.delta = [[0 for inf in range(self.num_inputs+1)]
69                       for outf in range(self.num_outputs)]
70
71     def output_values(self,input_values, training=False):
72         """Returns the outputs for the input values.
73         It remembers the values for the backprop.
74
75         Note in self.weights there is a weight list for every output,
76         so wts in self.weights loops over the outputs.
77         The bias is the *last* value of each list in self.weights.
78         """
79         self.inputs = input_values + [1]
80         return [sum(w*val for (w,val) in zip(wts,self.inputs))
81                for wts in self.weights]
82
83     def backprop(self,errors):
84         """Backpropagate the errors, updating the weights and returning the
85         error in its inputs.
86         """
87         input_errors = [0]*(self.num_inputs+1)
88         for out in range(self.num_outputs):
89             for inp in range(self.num_inputs+1):
90                 input_errors[inp] += self.weights[out][inp] * errors[out]
91                 self.delta[out][inp] += self.inputs[inp] * errors[out]
92         return input_errors[:-1] # remove the error for the "1"
93
94     def update(self):
95         """updates parameters after a batch"""
96         batch_step_size = self.nn.learning_rate / self.nn.batch_size
97         for out in range(self.num_outputs):
98             for inp in range(self.num_inputs+1):

```

```

97 |         self.weights[out][inp] -= batch_step_size *
98 |           self.delta[out][inp]
           self.delta[out][inp] = 0

```

### 8.1.2 ReLU Layer

The standard activation function for hidden nodes is the **ReLU**.

```

_____learnNN.py — (continued)_____
100 class ReLU_layer(Layer):
101     """Rectified linear unit (ReLU)  $f(z) = \max(0, z)$ .
102     The number of outputs is equal to the number of inputs.
103     """
104     def __init__(self, nn):
105         Layer.__init__(self, nn)
106
107     def output_values(self, input_values, training=False):
108         """Returns the outputs for the input values.
109         It remembers the input values for the backprop.
110         """
111         self.input_values = input_values
112         self.outputs= [max(0,inp) for inp in input_values]
113         return self.outputs
114
115     def backprop(self,errors):
116         """Returns the derivative of the errors"""
117         return [e if inp>0 else 0 for e,inp in zip(errors,
                self.input_values)]

```

### 8.1.3 Sigmoid Layer

One of the old standards for the activation function for hidden layers is the sigmoid. It is included here to experiment with.

```

_____learnNN.py — (continued)_____
119 class Sigmoid_layer(Layer):
120     """sigmoids of the inputs.
121     The number of outputs is equal to the number of inputs.
122     Each output is the sigmoid of its corresponding input.
123     """
124     def __init__(self, nn):
125         Layer.__init__(self, nn)
126
127     def output_values(self, input_values, training=False):
128         """Returns the outputs for the input values.
129         It remembers the output values for the backprop.
130         """
131         self.outputs= [sigmoid(inp) for inp in input_values]
132         return self.outputs

```

```

133
134     def backprop(self, errors):
135         """Returns the derivative of the errors"""
136         return [e*out*(1-out) for e,out in zip(errors, self.outputs)]

```

## 8.2 Feedforward Networks

learnNN.py — (continued)

```

138 class NN(Learner):
139     def __init__(self, dataset, validation_proportion = 0.1,
140                 learning_rate=0.001):
141         """Creates a neural network for a dataset,
142         layers is the list of layers
143         """
144         self.dataset = dataset
145         self.output_type = dataset.target.ftype
146         self.learning_rate = learning_rate
147         self.input_features = dataset.input_features
148         self.num_outputs = len(self.input_features)
149         validation_num = int(len(self.dataset.train)*validation_proportion)
150         if validation_num > 0:
151             random.shuffle(self.dataset.train)
152             self.validation_set = self.dataset.train[-validation_num:]
153             self.training_set = self.dataset.train[:-validation_num]
154         else:
155             self.validation_set = []
156             self.training_set = self.dataset.train
157         self.layers = []
158         self.bn = 0 # number of batches run
159
160     def add_layer(self, layer):
161         """add a layer to the network.
162         Each layer gets number of inputs from the previous layers outputs.
163         """
164         self.layers.append(layer)
165         self.num_outputs = layer.num_outputs
166
167     def predictor(self, ex):
168         """Predicts the value of the first output for example ex.
169         """
170         values = [f(ex) for f in self.input_features]
171         for layer in self.layers:
172             values = layer.output_values(values)
173         return sigmoid(values[0]) if self.output_type == "boolean" \
174             else softmax(values, self.dataset.target.frange) if
175             self.output_type == "categorical" \
176             else values[0]

```

```

176 | def predictor_string(self):
177 |     return "not implemented"

```

The *learn* method learns a network.

```

learnNN.py — (continued)
179 | def learn(self, epochs=5, batch_size=32, num_iter = None,
      |     report_each=10):
180 |     """Learns parameters for a neural network using stochastic gradient
      |     decent.
181 |     epochs is the number of times through the data (on average)
182 |     batch_size is the maximum size of each batch
183 |     num_iter is the number of iterations over the batches
184 |         - overrides epochs if provided (allows for fractions of epochs)
185 |     report_each means give the errors after each multiple of that
      |     iterations
186 |     """
187 |     self.batch_size = min(batch_size, len(self.training_set)) # don't
      |         have batches bigger than training size
188 |     if num_iter is None:
189 |         num_iter = (epochs * len(self.training_set)) // self.batch_size
190 |     #self.display(0, "Batch\t", "\t".join(criterion.__doc__ for criterion
      |         in Evaluate.all_criteria))
191 |     for i in range(num_iter):
192 |         batch = random.sample(self.training_set, self.batch_size)
193 |         for e in batch:
194 |             # compute all outputs
195 |             values = [f(e) for f in self.input_features]
196 |             for layer in self.layers:
197 |                 values = layer.output_values(values, training=True)
198 |             # backpropagate
199 |             predicted = [sigmoid(v) for v in values] if self.output_type
      |                 == "boolean" \
200 |                 else softmax(values) if self.output_type ==
      |                 "categorical" \
201 |                 else values
202 |             actuals = indicator(self.dataset.target(e),
      |                 self.dataset.target.frange) \
203 |                 if self.output_type == "categorical" \
204 |                 else [self.dataset.target(e)]
205 |             errors = [pred-obsd for (obsd,pred) in
      |                 zip(actuals,predicted)]
206 |             for layer in reversed(self.layers):
207 |                 errors = layer.backprop(errors)
208 |             # Update all parameters in batch
209 |             for layer in self.layers:
210 |                 layer.update()
211 |             self.bn+=1
212 |             if (i+1)%report_each==0:
213 |                 self.display(0, self.bn, "\t",
214 |                     "\t\t".join("{:.4f}".format(

```

```

215         self.dataset.evaluate_dataset(self.validation_set,
216                                     self.predictor, criterion))
                                     for criterion in Evaluate.all_criteria),
                                     sep="")

```

## 8.3 Improved Optimization

### 8.3.1 Momentum

learnNN.py — (continued)

```

218 class Linear_complete_layer_momentum(Linear_complete_layer):
219     """a completely connected layer"""
220     def __init__(self, nn, num_outputs, limit=None, alpha=0.9, epsilon =
221                 1e-07, vel0=0):
222         """A completely connected linear layer.
223         nn is a neural network that the inputs come from
224         num_outputs is the number of outputs
225         max_init is the maximum value for random initialization of
226         parameters
227         vel0 is the initial velocity for each parameter
228         """
229         Linear_complete_layer.__init__(self, nn, num_outputs, limit=limit)
230         # self.weights[o][i] is the weight between input i and output o
231         self.velocity = [[vel0 for inf in range(self.num_inputs+1)]
232                          for outf in range(self.num_outputs)]
233         self.alpha = alpha
234         self.epsilon = epsilon
235
236     def update(self):
237         """updates parameters after a batch"""
238         batch_step_size = self.nn.learning_rate / self.nn.batch_size
239         for outf in range(self.num_outputs):
240             for inp in range(self.num_inputs+1):
241                 self.velocity[out][inp] = self.alpha*self.velocity[out][inp]
242                 - batch_step_size * self.delta[out][inp]
243                 self.weights[out][inp] += self.velocity[out][inp]
244                 self.delta[out][inp] = 0

```

### 8.3.2 RMS-Prop

learnNN.py — (continued)

```

243 class Linear_complete_layer_RMS_Prop(Linear_complete_layer):
244     """a completely connected layer"""
245     def __init__(self, nn, num_outputs, limit=None, rho=0.9, epsilon =
246                 1e-07):
247         """A completely connected linear layer.
248         nn is a neural network that the inputs come from
249         num_outputs is the number of outputs

```

```

249     max_init is the maximum value for random initialization of
        parameters
250     """
251     Linear_complete_layer.__init__(self, nn, num_outputs, limit=limit)
252     # self.weights[o][i] is the weight between input i and output o
253     self.ms = [[0 for inf in range(self.num_inputs+1)]
254               for outf in range(self.num_outputs)]
255     self.rho = rho
256     self.epsilon = epsilon
257
258     def update(self):
259         """updates parameters after a batch"""
260         for out in range(self.num_outputs):
261             for inp in range(self.num_inputs+1):
262                 gradient = self.delta[out][inp] / self.nn.batch_size
263                 self.ms[out][inp] = self.rho*self.ms[out][inp]+ (1-self.rho)
264                     * gradient**2
265                 self.weights[out][inp] -=
266                     self.nn.learning_rate/(self.ms[out][inp]+self.epsilon)**0.5
267                     * gradient
268                 self.delta[out][inp] = 0

```

## 8.4 Dropout

Dropout is implemented as a layer.

```

learnNN.py — (continued)
267 from utilities import flip
268 class Dropout_layer(Layer):
269     """Dropout layer
270     """
271
272     def __init__(self, nn, rate=0):
273         """
274         rate is fraction of the input units to drop. 0 =< rate < 1
275         """
276         self.rate = rate
277         Layer.__init__(self, nn)
278
279     def output_values(self, input_values, training=False):
280         """Returns the outputs for the input values.
281         It remembers the input values for the backprop.
282         """
283         if training:
284             scaling = 1/(1-self.rate)
285             self.mask = [0 if flip(self.rate) else 1
286                         for _ in input_values]
287             return [x*y*scaling for (x,y) in zip(input_values, self.mask)]
288         else:
289             return input_values

```

```

290
291     def backprop(self, errors):
292         """Returns the derivative of the errors"""
293         return [x*y for (x,y) in zip(errors, self.mask)]
294
295 class Dropout_layer_0(Layer):
296     """Dropout layer
297     """
298
299     def __init__(self, nn, rate=0):
300         """
301         rate is fraction of the input units to drop. 0 =< rate < 1
302         """
303         self.rate = rate
304         Layer.__init__(self, nn)
305
306     def output_values(self, input_values, training=False):
307         """Returns the outputs for the input values.
308         It remembers the input values for the backprop.
309         """
310         if training:
311             scaling = 1/(1-self.rate)
312             self.outputs= [0 if flip(self.rate) else inp*scaling # make 0
313                            with probability rate
314                            for inp in input_values]
315         else:
316             return input_values
317
318     def backprop(self, errors):
319         """Returns the derivative of the errors"""
320         return errors

```

### 8.4.1 Examples

The following constructs a neural network with one hidden layer. The output is assumed to be Boolean or Real. If it is categorical, the final layer should have the same number of outputs as the number of categories (so it can use a softmax).

```

learnNN.py — (continued)
322 #data = Data_from_file('data/mail_reading.csv', target_index=-1)
323 #data = Data_from_file('data/mail_reading_consist.csv', target_index=-1)
324 data = Data_from_file('data/SPECT.csv', prob_test=0.3, target_index=0,
325                       seed=12345)
326 #data = Data_from_file('data/iris.data', prob_test=0.2, target_index=-1) #
327     150 examples approx 120 test + 30 test
328 #data = Data_from_file('data/if_x_then_y_else_z.csv', num_train=8,
329                       target_index=-1) # not linearly sep

```

```

327 #data = Data_from_file('data/holiday.csv', target_index=-1) #,
      num_train=19)
328 #data = Data_from_file('data/processed.cleveland.data', target_index=-1)
329 #random.seed(None)
330
331 # nn3 is has a single hidden layer of width 3
332 nn3 = NN(data, validation_proportion = 0)
333 nn3.add_layer(Linear_complete_layer(nn3,3))
334 #nn3.add_layer(Sigmoid_layer(nn3))
335 nn3.add_layer(ReLU_layer(nn3))
336 nn3.add_layer(Linear_complete_layer(nn3,1)) # when using
      output_type="boolean"
337 #nn3.learn(epochs = 100)
338
339 # nn3do is like nn3 but with dropout on the hidden layer
340 nn3do = NN(data, validation_proportion = 0)
341 nn3do.add_layer(Linear_complete_layer(nn3do,3))
342 #nn3.add_layer(Sigmoid_layer(nn3)) # comment this or the next
343 nn3do.add_layer(ReLU_layer(nn3do))
344 nn3do.add_layer(Dropout_layer(nn3do, rate=0.5))
345 nn3do.add_layer(Linear_complete_layer(nn3do,1))
346 #nn3do.learn(epochs = 100)
347
348 # nn3_rmsp is like nn3 but uses RMS prop
349 nn3_rmsp = NN(data, validation_proportion = 0)
350 nn3_rmsp.add_layer(Linear_complete_layer_RMS_Prop(nn3_rmsp,3))
351 #nn3_rmsp.add_layer(Sigmoid_layer(nn3_rmsp)) # comment this or the next
352 nn3_rmsp.add_layer(ReLU_layer(nn3_rmsp))
353 nn3_rmsp.add_layer(Linear_complete_layer_RMS_Prop(nn3_rmsp,1))
354 #nn3_rmsp.learn(epochs = 100)
355
356 # nn3_m is like nn3 but uses momentum
357 mm1_m = NN(data, validation_proportion = 0)
358 mm1_m.add_layer(Linear_complete_layer_momentum(mm1_m,3))
359 #mm1_m.add_layer(Sigmoid_layer(mm1_m)) # comment this or the next
360 mm1_m.add_layer(ReLU_layer(mm1_m))
361 mm1_m.add_layer(Linear_complete_layer_momentum(mm1_m,1))
362 #mm1_m.learn(epochs = 100)
363
364 # nn2 has a single a hidden layer of width 2
365 nn2 = NN(data, validation_proportion = 0)
366 nn2.add_layer(Linear_complete_layer_RMS_Prop(nn2,2))
367 nn2.add_layer(ReLU_layer(nn2))
368 nn2.add_layer(Linear_complete_layer_RMS_Prop(nn2,1))
369
370 # nn5 is has a single hidden layer of width 5
371 nn5 = NN(data, validation_proportion = 0)
372 nn5.add_layer(Linear_complete_layer_RMS_Prop(nn5,5))
373 nn5.add_layer(ReLU_layer(nn5))
374 nn5.add_layer(Linear_complete_layer_RMS_Prop(nn5,1))

```

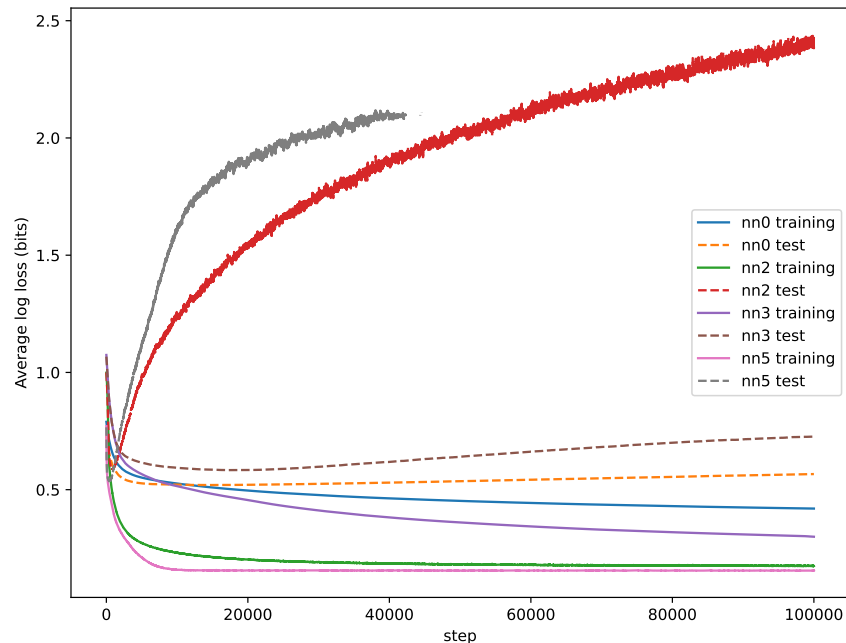

Figure 8.1: Plotting train and test log loss for various algorithms on SPECT dataset

```

375
376 # nn0 has no hidden layers, and so is just logistic regression:
377 nn0 = NN(data, validation_proportion = 0) #learning_rate=0.05
378 nn0.add_layer(Linear_complete_layer(nn0,1))
379 # Or try this for RMS-Prop:
380 #nn0.add_layer(Linear_complete_layer_RMS_Prop(nn0,1))

```

Plotting. Figure 8.1 shows the training and test performance on the SPECT dataset for the architectures above. Note the nn5 test has infinite log loss on the test set after about 45,000 steps. The noisyness of the predictions might indicate that the step size is too big. This was produced by the code below:

```

learnNN.py — (continued)
382 from learnLinear import plot_steps
383 from learnProblem import Evaluate
384
385 # To show plots first choose a criterion to use
386 # crit = Evaluate.log_loss
387 # crit = Evaluate.accuracy
388 # plot_steps(learner = nn0, data = data, criterion=crit, num_steps=10000,
    log_scale=False, legend_label="nn0")

```

```

389 # plot_steps(learner = nn2, data = data, criterion=crit, num_steps=10000,
      log_scale=False, legend_label="nn2")
390 # plot_steps(learner = nn3, data = data, criterion=crit, num_steps=10000,
      log_scale=False, legend_label="nn3")
391 # plot_steps(learner = nn5, data = data, criterion=crit, num_steps=10000,
      log_scale=False, legend_label="nn5")
392
393 # for (nn,nname) in [(nn0,"nn0"),(nn2,"nn2"),(nn3,"nn3"),(nn5,"nn5")]:
      plot_steps(learner = nn, data = data, criterion=crit,
      num_steps=100000, log_scale=False, legend_label=nname)
394
395 # Print some training examples
396 #for eg in random.sample(data.train,10): print(eg,nn3.predictor(eg))
397
398 # Print some test examples
399 #for eg in random.sample(data.test,10): print(eg,nn3.predictor(eg))
400
401 # To see the weights learned in linear layers
402 # nn3.layers[0].weights
403 # nn3.layers[2].weights
404
405 # Print test:
406 # for e in data.train: print(e,nn0.predictor(e))
407
408 def test(data, hidden_widths = [5], epochs=100,
409         optimizers = [Linear_complete_layer,
410                       Linear_complete_layer_momentum,
411                       Linear_complete_layer_RMS_Prop]):
412     data.display(0,"Batch\t","\t".join(criterion.__doc__ for criterion in
413     Evaluate.all_criteria))
414     for optimizer in optimizers:
415         nn = NN(data)
416         for width in hidden_widths:
417             nn.add_layer(optimizer(nn,width))
418             nn.add_layer(ReLU_layer(nn))
419         if data.target.ftype == "boolean":
420             nn.add_layer(optimizer(nn,1))
421         else:
422             error(f"Not implemented: {data.output_type}")
423     nn.learn(epochs)

```

The following tests on MNIST. The original files are from <http://yann.lecun.com/exdb/mnist/>. This code assumes you use the csv files from <https://pjreddie.com/projects/mnist-in-csv/>, and put them in the directory `../MNIST/`. Note that this is **very** inefficient; you would be better to use Keras or Pytorch. There are  $28 * 28 = 784$  input units and 512 hidden units, which makes 401,408 parameters for the lowest linear layer. So don't be surprised when it takes many hours in AIPython (even if it only takes a few seconds in Keras).

```

423 # Simplified version: (6000 training instances)
424 # data_mnist = Data_from_file('../MNIST/mnist_train.csv', prob_test=0.9,
      target_index=0, boolean_features=False, target_type="categorical")
425
426 # Full version:
427 # data_mnist = Data_from_files('../MNIST/mnist_train.csv',
      '../MNIST/mnist_test.csv', target_index=0, boolean_features=False,
      target_type="categorical")
428
429 # nn_mnist = NN(data_mnist, validation_proportion = 0.02,
      learning_rate=0.001) #validation set = 1200
430 # nn_mnist.add_layer(Linear_complete_layer_RMS_Prop(nn_mnist,512));
      nn_mnist.add_layer(ReLU_layer(nn_mnist));
      nn_mnist.add_layer(Linear_complete_layer_RMS_Prop(nn_mnist,10))
431 # start_time = time.perf_counter();nn_mnist.learn(epochs=1,
      batch_size=128);end_time = time.perf_counter();print("Time:", end_time
      - start_time,"seconds") #1 epoch
432 # determine test error:
433 # data_mnist.evaluate_dataset(data_mnist.test, nn_mnist.predictor,
      Evaluate.accuracy)
434 # Print some random predictions:
435 # for eg in random.sample(data_mnist.test,10):
      print(data_mnist.target(eg),nn_mnist.predictor(eg),nn_mnist.predictor(eg)[data_mnist.target(eg)

```

**Exercise 8.1** In the definition of *nn3* above, for each of the following, first hypothesize what will happen, then test your hypothesis, then explain whether you testing confirms your hypothesis or not. Test it for more than one data set, and use more than one run for each data set.

- Which fits the data better, having a sigmoid layer or a ReLU layer after the first linear layer?
- Which is faster, having a sigmoid layer or a ReLU layer after the first linear layer?
- What happens if you have both the sigmoid layer and then a ReLU layer after the first linear layer and before the second linear layer?
- What happens if you have a ReLU layer then a sigmoid layer after the first linear layer and before the second linear layer?
- What happens if you have neither the sigmoid layer nor a ReLU layer after the first linear layer?

**Exercise 8.2** Do some



## Reasoning with Uncertainty

### 9.1 Representing Probabilistic Models

A probabilistic model uses the same definition of a variable as a CSP (Section 4.1.1, page 69). A variable consists of a name, a domain and an optional  $(x,y)$  position (for displaying). The domain of a variable is a list or a tuple, as the ordering will matter in the representation of factors.

### 9.2 Representing Factors

A **factor** is, mathematically, a function from variables into a number; that is given a value for each of its variable, it gives a number. Factors are used for conditional probabilities, utilities in the next chapter, and are explicitly constructed by some algorithms (in particular variable elimination).

A variable assignment, or just **assignment**, is represented as a  $\{variable : value\}$  dictionary. A factor can be evaluated when all of its variables are assigned. The method `get_value` evaluates the factor for an assignment. The assignment can include extra variables not in the factor. This method needs to be defined for every subclass.

```
_____probFactors.py — Factors for graphical models_____
11 from display import Displayable
12 import math
13
14 class Factor(Displayable):
15     nextid=0 # each factor has a unique identifier; for printing
16
17     def __init__(self, variables, name=None):
18         self.variables = variables # list of variables
```

```

19     if name:
20         self.name = name
21     else:
22         self.name = f"f{Factor.nextid}"
23         Factor.nextid += 1
24
25     def can_evaluate(self, assignment):
26         """True when the factor can be evaluated in the assignment
27         assignment is a {variable:value} dict
28         """
29         return all(v in assignment for v in self.variables)
30
31     def get_value(self, assignment):
32         """Returns the value of the factor given the assignment of values
33         to variables.
34         Needs to be defined for each subclass.
35         """
36         assert self.can_evaluate(assignment)
37         raise NotImplementedError("get_value") # abstract method

```

The method `__str__` returns a brief definition (like `"f7(X,Y,Z)"`). The method `to_table` returns string representations of a table showing all of the assignments of values to variables, and the corresponding value.

```

_____probFactors.py — (continued)_____
38     def __str__(self):
39         """returns a string representing a summary of the factor"""
40         return f"{self.name}({'.'.join(str(var) for var in
41             self.variables)})"
42
43     def to_table(self, variables=None, given={}):
44         """returns a string representation of the factor.
45         Allows for an arbitrary variable ordering.
46         variables is a list of the variables in the factor
47         (can contain other variables)"""
48         if variables==None:
49             variables = [v for v in self.variables if v not in given]
50         else: #enforce ordering and allow for extra variables in ordering
51             variables = [v for v in variables if v in self.variables and v
52                 not in given]
53         head = "\t".join(str(v) for v in variables)+"\t"+self.name
54         return head+"\n"+self.ass_to_str(variables, given, variables)
55
56     def ass_to_str(self, vars, asst, allvars):
57         #print(f"ass_to_str({vars}, {asst}, {allvars})")
58         if vars:
59             return "\n".join(self.ass_to_str(vars[1:], {**asst,
60                 vars[0]:val}, allvars)
61                 for val in vars[0].domain)
62         else:
63             val = self.get_value(asst)

```

```

61         val_st = "{:.6f}".format(val) if isinstance(val, float) else
           str(val)
62         return "\t".join(str(asst[var]) for var in allvars)
63             + "\t"+val_st)
64
65     __repr__ = __str__

```

## 9.3 Conditional Probability Distributions

A **conditional probability distribution (CPD)** is a type of factor that represents a conditional probability. A CPD representing  $P(X \mid Y_1 \dots Y_k)$  is a type of factor, where given values for  $X$  and each  $Y_i$  returns a number.

probFactors.py — (continued)

```

67 class CPD(Factor):
68     def __init__(self, child, parents):
69         """represents P(variable | parents)
70         """
71         self.parents = parents
72         self.child = child
73         Factor.__init__(self, parents+[child], name=f"Probability")
74
75     def __str__(self):
76         """A brief description of a factor using in tracing"""
77         if self.parents:
78             return f"P({self.child}|{' '.join(str(p) for p in
79                 self.parents)})"
80         else:
81             return f"P({self.child})"
82
83     __repr__ = __str__

```

A constant CPD has no parents, and has probability 1 when the variable has the value specified, and 0 when the variable has a different value.

probFactors.py — (continued)

```

84 class ConstantCPD(CPD):
85     def __init__(self, variable, value):
86         CPD.__init__(self, variable, [])
87         self.value = value
88     def get_value(self, assignment):
89         return 1 if self.value==assignment[self.child] else 0

```

### 9.3.1 Logistic Regression

A **logistic regression** CPD, for Boolean variable  $X$  represents  $P(X=True \mid Y_1 \dots Y_k)$ , using  $k + 1$  real-values weights so

$$P(X=True \mid Y_1 \dots Y_k) = \text{sigmoid}(w_0 + \sum_i w_i Y_i)$$

where for Boolean  $Y_i$ , True is represented as 1 and False as 0.

```

-----probFactors.py ----- (continued) -----
91 from learnLinear import sigmoid, logit
92
93 class LogisticRegression(CPD):
94     def __init__(self, child, parents, weights):
95         """A logistic regression representation of a conditional
96            probability.
97            child is the Boolean (or 0/1) variable whose CPD is being defined
98            parents is the list of parents
99            weights is list of parameters, such that weights[i+1] is the weight
100               for parents[i]
101            """
102         assert len(weights) == 1+len(parents)
103         CPD.__init__(self, child, parents)
104         self.weights = weights
105
106     def get_value(self, assignment):
107         assert self.can_evaluate(assignment)
108         prob = sigmoid(self.weights[0]
109                       + sum(self.weights[i+1]*assignment[self.parents[i]]
110                           for i in range(len(self.parents))))
111         if assignment[self.child]: #child is true
112             return prob
113         else:
114             return (1-prob)

```

### 9.3.2 Noisy-or

A **noisy-or**, for Boolean variable  $X$  with Boolean parents  $Y_1 \dots Y_k$  is parametrized by  $k + 1$  parameters  $p_0, p_1, \dots, p_k$ , where each  $0 \leq p_i \leq 1$ . The semantics is defined as though there are  $k + 1$  hidden variables  $Z_0, Z_1 \dots Z_k$ , where  $P(Z_0) = p_0$  and  $P(Z_i | Y_i) = p_i$  for  $i \geq 1$ , and where  $X$  is true if and only if  $Z_0 \vee Z_1 \vee \dots \vee Z_k$  (where  $\vee$  is “or”). Thus  $X$  is false if all of the  $Z_i$  are false. Intuitively,  $Z_0$  is the probability of  $X$  when all  $Y_i$  are false and each  $Z_i$  is a noisy (probabilistic) measure that  $Y_i$  makes  $X$  true, and  $X$  only needs one to make it true.

```

-----probFactors.py ----- (continued) -----
114 class NoisyOR(CPD):
115     def __init__(self, child, parents, weights):
116         """A noisy representation of a conditional probability.
117            variable is the Boolean (or 0/1) child variable whose CPD is being
118               defined
119            parents is the list of Boolean (or 0/1) parents
120            weights is list of parameters, such that weights[i+1] is the weight
121               for parents[i]
122            """
123         assert len(weights) == 1+len(parents)

```

```

122     CPD.__init__(self, child, parents)
123     self.weights = weights
124
125     def get_value(self, assignment):
126         assert self.can_evaluate(assignment)
127         probfalse = (1-self.weights[0])*math.prod(1-self.weights[i+1]
128                                                     for i in
129                                                         range(len(self.parents))
130                                                         if
131                                                             assignment[self.parents[i]])
132
133     if assignment[self.child]:
134         return 1-probfalse
135     else:
136         return probfalse

```

### 9.3.3 Tabular Factors and Prob

A **tabular factor** is a factor that represents each assignment of values to variables separately. It is represented by a Python array (or python dict). If the variables are  $V_1, V_2, \dots, V_k$ , the value of  $f(V_1 = v_1, V_2 = v_2, \dots, V_k = v_k)$  is stored in  $f[v_1][v_2] \dots [v_k]$ .

If the domain of  $V_i$  is  $[0, \dots, n_i - 1]$  this can be represented as an array. Otherwise we can use a dictionary. Python is nice in that it doesn't care, whether an array or dict is used **except when enumerating the values**; enumerating a dict gives the keys (the variables) but enumerating an array gives the values. So we have to be careful not to do this.

probFactors.py — (continued)

```

135 class TabFactor(Factor):
136
137     def __init__(self, variables, values, name=None):
138         Factor.__init__(self, variables, name=name)
139         self.values = values
140
141     def get_value(self, assignment):
142         return self.get_val_rec(self.values, self.variables, assignment)
143
144     def get_val_rec(self, value, variables, assignment):
145         if variables == []:
146             return value
147         else:
148             return self.get_val_rec(value[assignment[variables[0]]],
149                                     variables[1:], assignment)

```

*Prob* is a factor that represents a conditional probability by enumerating all of the values.

probFactors.py — (continued)

```

151 class Prob(CPD, TabFactor):

```

```

152     """A factor defined by a conditional probability table"""
153     def __init__(self, var, pars, cpt, name=None):
154         """Creates a factor from a conditional probability table, cpt
155         The cpt values are assumed to be for the ordering par+[var]
156         """
157         TabFactor.__init__(self, pars+[var], cpt, name)
158         self.child = var
159         self.parents = pars

```

### 9.3.4 Decision Tree Representations of Factors

A decision tree representation of a conditional probability is either:

- IFeq(var, val, true\_cond, false\_cond) where true\_cond and false\_cond are decision trees. true\_cond is used if variable var has value val in an assignment; false\_cond is used if var has a different value.
- a distribution over the child variable

Note that not all parents needs to be assigned to evaluate the decision tree; you only need the branch down the tree that gives the distribution.

```

_____probFactors.py — (continued)_____
161 class ProbDT(CPD):
162     def __init__(self, child, parents, dt):
163         CPD.__init__(self, child, parents)
164         self.dt = dt
165
166     def get_value(self, assignment):
167         return self.dt.get_value(assignment, self.child)
168
169     def can_evaluate(self, assignment):
170         return self.child in assignment and self.dt.can_evaluate(assignment)

```

Decision trees are made up of conditons; here equality equality of a value and a variable:

```

_____probFactors.py — (continued)_____
172 class IFeq:
173     def __init__(self, var, val, true_cond, false_cond):
174         self.var = var
175         self.val = val
176         self.true_cond = true_cond
177         self.false_cond = false_cond
178
179     def get_value(self, assignment, child):
180         if assignment[self.var] == self.val:
181             return self.true_cond.get_value(assignment, child)
182         else:
183             return self.false_cond.get_value(assignment, child)

```

```

184
185     def can_evaluate(self, assignment):
186         if self.var not in assignment:
187             return False
188         elif assignment[self.var] == self.val:
189             return self.true_cond.can_evaluate(assignment)
190         else:
191             return self.false_cond.can_evaluate(assignment)

```

At the leaves are distributions over the child variable.

```

_____probFactors.py — (continued)_____
193 class Dist:
194     def __init__(self, dist):
195         """Dist is an array or dictionary indexed by value of current
196            child"""
197         self.dist = dist
198
199     def get_value(self, assignment, child):
200         return self.dist[assignment[child]]
201
202     def can_evaluate(self, assignment):
203         return True

```

The following shows a decision representation of the Example 9.18 of Poole and Mackworth [2023]. When the Action is to go out, the probability is a function of rain; otherwise it is a function of full.

```

_____probFactors.py — (continued)_____
204 ##### A decision tree representation Example 9.18 of AIFCA 3e
205 from variable import Variable
206
207 boolean = [False, True]
208
209 action = Variable('Action', ['go_out', 'get_coffee'], position=(0.5,0.8))
210 rain = Variable('Rain', boolean, position=(0.2,0.8))
211 full = Variable('Cup Full', boolean, position=(0.8,0.8))
212
213 wet = Variable('Wet', boolean, position=(0.5,0.2))
214 p_wet = ProbDT(wet,[action,rain,full],
215               IFeq(action, 'go_out',
216                   IFeq(rain, True, Dist([0.2,0.8]),
217                         Dist([0.9,0.1])),
218                   IFeq(full, True, Dist([0.4,0.6]),
219                         Dist([0.7,0.3])))
219 # See probRC for wetBN which expands this example to a complete network

```

## 9.4 Graphical Models

A graphical model consists of a set of variables and a set of factors. A belief network is a graphical model where all of the factors represent conditional probabilities. There are some operations (such as pruning variables) which are applicable to belief networks, but are not applicable to more general models. At the moment, we will treat them as the same.

```

_____probGraphicalModels.py — Graphical Models and Belief Networks _____
11 from display import Displayable
12 from probFactors import CPD
13 import matplotlib.pyplot as plt
14
15 class GraphicalModel(Displayable):
16     """The class of graphical models.
17     A graphical model consists of a title, a set of variables and a set of
18         factors.
19     vars is a set of variables
20     factors is a set of factors
21     """
22     def __init__(self, title, variables=None, factors=None):
23         self.title = title
24         self.variables = variables
25         self.factors = factors

```

A **belief network** (also known as a **Bayesian network**) is a graphical model where all of the factors are conditional probabilities, and every variable has a conditional probability of it given its parents. This only checks the first condition, and builds some useful data structures.

```

_____probGraphicalModels.py — (continued) _____
27 class BeliefNetwork(GraphicalModel):
28     """The class of belief networks."""
29
30     def __init__(self, title, variables, factors):
31         """vars is a set of variables
32         factors is a set of factors. All of the factors are instances of
33             CPD (e.g., Prob).
34             """
35         GraphicalModel.__init__(self, title, variables, factors)
36         assert all(isinstance(f,CPD) for f in factors), factors
37         self.var2cpt = {f.child:f for f in factors}
38         self.var2parents = {f.child:f.parents for f in factors}
39         self.children = {n:[] for n in self.variables}
40         for v in self.var2parents:
41             for par in self.var2parents[v]:
42                 self.children[par].append(v)

```

The following creates a topological sort of the nodes, where the parents of a node come before the node in the resulting order. This is based on Kahn's algorithm from 1962.

```

probGraphicalModels.py — (continued)
44 def topological_sort(self):
45     """creates a topological ordering of variables such that the
46     parents of
47     a node are before the node.
48     """
49     if self.topological_sort_saved:
50         return self.topological_sort_saved
51     next_vars = {n for n in self.var2parents if not self.var2parents[n]}
52     self.display(3, 'topological_sort: next_vars', next_vars)
53     top_order=[]
54     while next_vars:
55         var = next_vars.pop()
56         self.display(3, 'select variable', var)
57         top_order.append(var)
58         next_vars |= {ch for ch in self.children[var]
59                     if all(p in top_order for p in
60                           self.var2parents[ch])}
61         self.display(3, 'var_with_no_parents_left', next_vars)
62     self.display(3, "top_order", top_order)
63     assert
64         set(top_order)==set(self.var2parents), (top_order, self.var2parents)
65     self.topologicalsort_saved=top_order
66     return top_order

```

### 9.4.1 Showing Belief Networks

The `show` method uses `matplotlib` to show the graphical structure of a belief network.

```

probGraphicalModels.py — (continued)
65 def show(self, fontsize=10, facecolor='orange'):
66     plt.ion() # interactive
67     ax = plt.figure().gca()
68     ax.set_axis_off()
69     plt.title(self.title, fontsize=fontsize)
70     bbox =
71         dict(boxstyle="round4,pad=1.0,rounding_size=0.5",facecolor=facecolor)
72     for var in self.variables: #reversed(self.topological_sort()):
73         for par in self.var2parents[var]:
74             ax.annotate(var.name, par.position, xytext=var.position,
75                         arrowprops={'arrowstyle':'<-'},bbox=bbox,
76                                 ha='center', va='center',
77                                 fontsize=fontsize)

```

4-chain

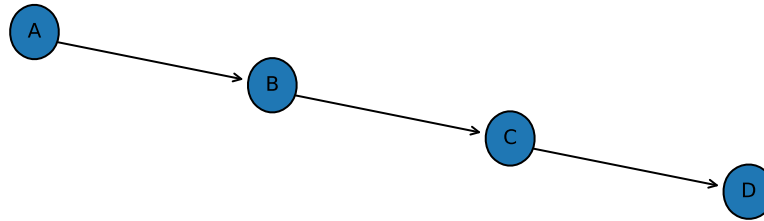

Figure 9.1: bn\_4ch.show()

```

76     for var in self.variables:
77         x,y = var.position
78         plt.text(x,y,var.name,bbox=bbox,ha='center', va='center',
                 fontsize=fontsize)

```

## 9.4.2 Example Belief Networks

### A Chain of 4 Variables

The first example belief network is a simple chain  $A \rightarrow B \rightarrow C \rightarrow D$ , shown in Figure 9.1.

Please do not change this, as it is the example used for testing.

```

_____probExamples.py — Example belief networks_____
11 from variable import Variable
12 from probFactors import CPD, Prob, LogisticRegression, NoisyOR, ConstantCPD
13 from probGraphicalModels import BeliefNetwork
14
15 ##### Simple Example Used for Unit Tests #####
16 boolean = [False, True]
17 A = Variable("A", boolean, position=(0,0.8))
18 B = Variable("B", boolean, position=(0.333,0.7))
19 C = Variable("C", boolean, position=(0.666,0.6))
20 D = Variable("D", boolean, position=(1,0.5))
21
22 f_a = Prob(A,[],[0.4,0.6])
23 f_b = Prob(B,[A],[[0.9,0.1],[0.2,0.8]])
24 f_c = Prob(C,[B],[[0.6,0.4],[0.3,0.7]])
25 f_d = Prob(D,[C],[[0.1,0.9],[0.75,0.25]])
26
27 bn_4ch = BeliefNetwork("4-chain", {A,B,C,D}, {f_a,f_b,f_c,f_d})

```

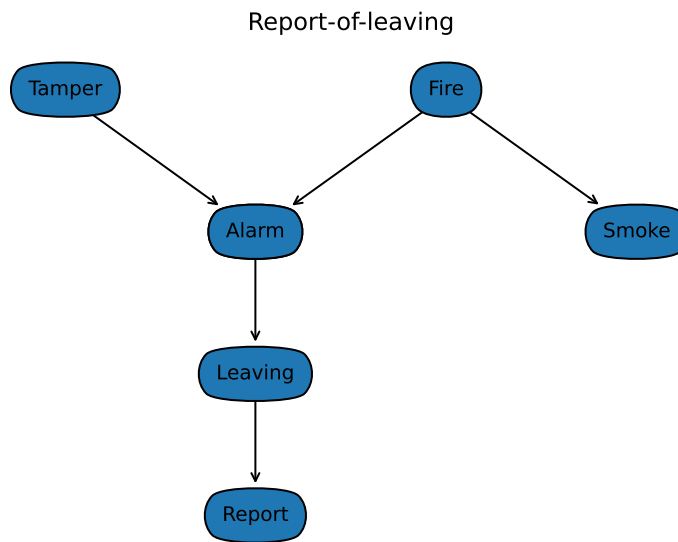

Figure 9.2: The report-of-leaving belief network

### Report-of-Leaving Example

The second belief network, `bn_report`, is Example 9.13 of Poole and Mackworth [2023] (<http://artint.info>). The output of `bn_report.show()` is shown in Figure 9.2 of this document.

probExamples.py — (continued)

```

29 # Belief network report-of-leaving example (Example 9.13 shown in Figure
    9.3) of
30 # Poole and Mackworth, Artificial Intelligence, 2023 http://artint.info
31 boolean = [False, True]
32
33 Alarm = Variable("Alarm", boolean, position=(0.366,0.5))
34 Fire = Variable("Fire", boolean, position=(0.633,0.75))
35 Leaving = Variable("Leaving", boolean, position=(0.366,0.25))
36 Report = Variable("Report", boolean, position=(0.366,0.0))
37 Smoke = Variable("Smoke", boolean, position=(0.9,0.5))
38 Tamper = Variable("Tamper", boolean, position=(0.1,0.75))
39
40 f_ta = Prob(Tamper,[],[0.98,0.02])
41 f_fi = Prob(Fire,[],[0.99,0.01])
42 f_sm = Prob(Smoke,[Fire],[[0.99,0.01],[0.1,0.9]])
43 f_al = Prob(Alarm,[Fire,Tamper],[[[0.9999, 0.0001], [0.15, 0.85]], [[0.01,
    0.99], [0.5, 0.5]])
44 f_lv = Prob(Leaving,[Alarm],[[0.999, 0.001], [0.12, 0.88]])
  
```

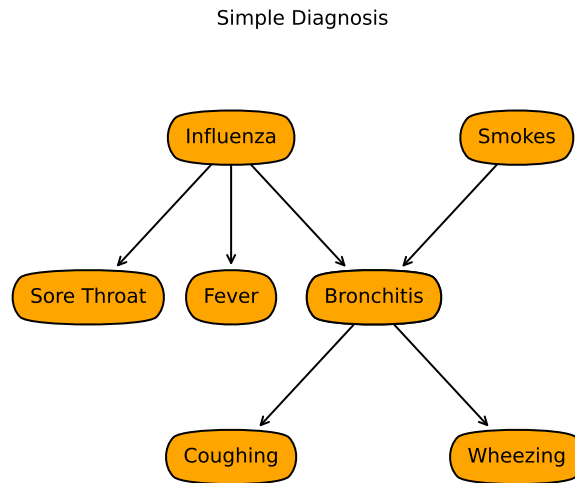

Figure 9.3: Simple diagnosis example; `simple_diagnosis.show()`

```

45 | f_re = Prob(Report,[Leaving],[[0.99, 0.01], [0.25, 0.75]])
46 |
47 | bn_report = BeliefNetwork("Report-of-leaving",
48 |     {Tamper,Fire,Smoke,Alarm,Leaving,Report},
49 |     {f_ta,f_fi,f_sm,f_al,f_lv,f_re})

```

### Simple Diagnostic Example

This is the “simple diagnostic example” of Exercise 9.1 of Poole and Mackworth [2023], reproduced here as Figure 9.3

```

probExamples.py — (continued)
50 | # Belief network simple-diagnostic example (Exercise 9.3 shown in Figure
51 |     9.39) of
52 | # Poole and Mackworth, Artificial Intelligence, 2023 http://artint.info
53 | Influenza = Variable("Influenza", boolean, position=(0.4,0.8))
54 | Smokes = Variable("Smokes", boolean, position=(0.8,0.8))
55 | SoreThroat = Variable("Sore Throat", boolean, position=(0.2,0.5))
56 | HasFever = Variable("Fever", boolean, position=(0.4,0.5))
57 | Bronchitis = Variable("Bronchitis", boolean, position=(0.6,0.5))
58 | Coughing = Variable("Coughing", boolean, position=(0.4,0.2))
59 | Wheezing = Variable("Wheezing", boolean, position=(0.8,0.2))
60 |
61 | p_infl = Prob(Influenza,[],[0.95,0.05])
62 | p_smokes = Prob(Smokes,[],[0.8,0.2])
63 | p_sth = Prob(SoreThroat,[Influenza],[[0.999,0.001],[0.7,0.3]])
64 | p_fever = Prob(HasFever,[Influenza],[[0.99,0.05],[0.9,0.1]])
65 | p_bronc = Prob(Bronchitis,[Influenza,Smokes],[[[0.9999, 0.0001], [0.3,
66 |     0.7]], [[0.1, 0.9], [0.01, 0.99]])

```

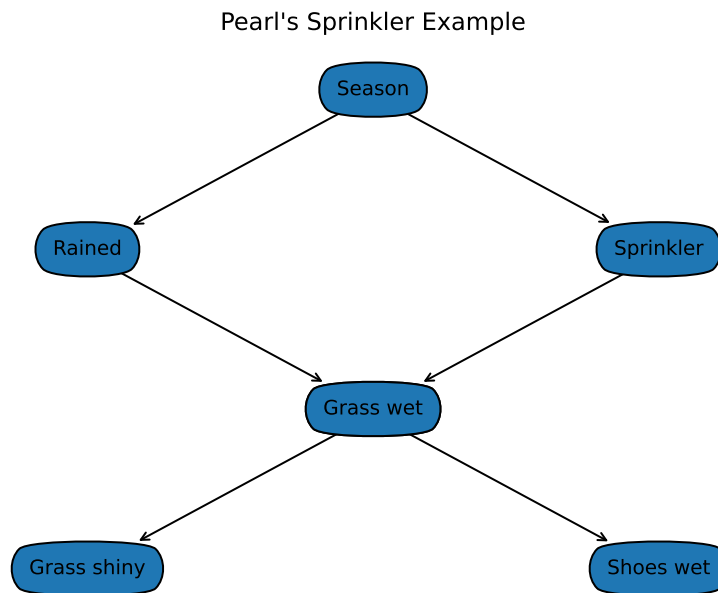

Figure 9.4: The sprinkler belief network

```

66 p_cough = Prob(Coughing,[Bronchitis],[[0.93,0.07],[0.2,0.8]])
67 p_wheeze = Prob(Wheezing,[Bronchitis],[[0.999,0.001],[0.4,0.6]])
68
69 simple_diagnosis = BeliefNetwork("Simple Diagnosis",
70     {Influenza, Smokes, SoreThroat, HasFever, Bronchitis,
71     Coughing, Wheezing},
72     {p_infl, p_smokes, p_sth, p_fever, p_bronc, p_cough,
73     p_wheeze})

```

### Sprinkler Example

The third belief network is the sprinkler example from Pearl. The output of `bn_sprinkler.show()` is shown in Figure 9.4 of this document.

probExamples.py — (continued)

```

73 Season = Variable("Season", ["dry_season", "wet_season"],
74     position=(0.5,0.9))
75 Sprinkler = Variable("Sprinkler", ["on", "off"], position=(0.9,0.6))
76 Rained = Variable("Rained", boolean, position=(0.1,0.6))
77 Grass_wet = Variable("Grass wet", boolean, position=(0.5,0.3))
78 Grass_shiny = Variable("Grass shiny", boolean, position=(0.1,0))
79 Shoes_wet = Variable("Shoes wet", boolean, position=(0.9,0))
80 f_season = Prob(Season,[],{'dry_season':0.5, 'wet_season':0.5})

```

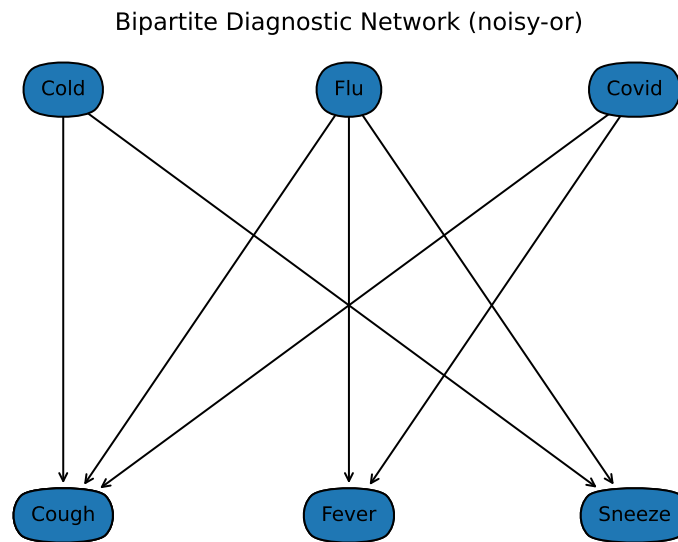

Figure 9.5: A bipartite diagnostic network

```

81 f_sprinkler = Prob(Sprinkler,[Season],{'dry_season':{'on':0.4,'off':0.6},
82                                     'wet_season':{'on':0.01,'off':0.99}})
83 f_rained = Prob(Rained,[Season],{'dry_season':[0.9,0.1], 'wet_season':
84   [0.2,0.8]})
84 f_wet = Prob(Grass_wet,[Sprinkler,Rained], {'on': [[0.1,0.9],[0.01,0.99]],
85   'off':[[0.99,0.01],[0.3,0.7]]})
86 f_shiny = Prob(Grass_shiny, [Grass_wet], [[0.95,0.05], [0.3,0.7]])
87 f_shoes = Prob(Shoes_wet, [Grass_wet], [[0.98,0.02], [0.35,0.65]])
88
89 bn_sprinkler = BeliefNetwork("Pearl's Sprinkler Example",
90   {Season, Sprinkler, Rained, Grass_wet, Grass_shiny,
91     Shoes_wet},
92   {f_season, f_sprinkler, f_rained, f_wet, f_shiny,
93     f_shoes})
  
```

### Bipartite Diagnostic Model with Noisy-or

The belief network `bn_no1` is a bipartite diagnostic model, with independent diseases, and the symptoms depend on the diseases, where the CPDs are defined using noisy-or. Bipartite means it is in two parts; the diseases are only connected to the symptoms and the symptoms are only connected to the diseases. The output of `bn_no1.show()` is shown in Figure 9.5 of this document.

```

probExamples.py — (continued)
93 ##### Bipartite Diagnostic Network #####
94 Cough = Variable("Cough", boolean, (0.1,0.1))
95 Fever = Variable("Fever", boolean, (0.5,0.1))
96 Sneeze = Variable("Sneeze", boolean, (0.9,0.1))
97 Cold = Variable("Cold",boolean, (0.1,0.9))
98 Flu = Variable("Flu",boolean, (0.5,0.9))
99 Covid = Variable("Covid",boolean, (0.9,0.9))
100
101 p_cold_no = Prob(Cold,[],[0.9,0.1])
102 p_flu_no = Prob(Flu,[],[0.95,0.05])
103 p_covid_no = Prob(Covid,[],[0.99,0.01])
104
105 p_cough_no = NoisyOR(Cough, [Cold,Flu,Covid], [0.1, 0.3, 0.2, 0.7])
106 p_fever_no = NoisyOR(Fever, [ Flu,Covid], [0.01, 0.6, 0.7])
107 p_sneeze_no = NoisyOR(Sneeze, [Cold,Flu ], [0.05, 0.5, 0.2 ])
108
109 bn_no1 = BeliefNetwork("Bipartite Diagnostic Network (noisy-or)",
110                        {Cough, Fever, Sneeze, Cold, Flu, Covid},
111                        {p_cold_no, p_flu_no, p_covid_no, p_cough_no,
112                         p_fever_no, p_sneeze_no})
112
113 # to see the conditional probability of Noisy-or do:
114 # print(p_cough_no.to_table())
115
116 # example from box "Noisy-or compared to logistic regression"
117 # X = Variable("X",boolean)
118 # w0 = 0.01
119 # print(NoisyOR(X,[A,B,C,D],[w0, 1-(1-0.05)/(1-w0), 1-(1-0.1)/(1-w0),
120                1-(1-0.2)/(1-w0), 1-(1-0.2)/(1-w0), ]).to_table(given={X:True}))

```

### Bipartite Diagnostic Model with Logistic Regression

The belief network `bn_lr1` is a bipartite diagnostic model, with independent diseases, and the symptoms depend on the diseases, where the CPDs are defined using logistic regression. It has the same graphical structure as the previous example (see Figure 9.5). This has the (approximately) the same conditional probabilities as the previous example when zero or one diseases are present. Note that  $\text{sigmoid}(-2.2) \approx 0.1$

```

probExamples.py — (continued)
121
122 p_cold_lr = Prob(Cold,[],[0.9,0.1])
123 p_flu_lr = Prob(Flu,[],[0.95,0.05])
124 p_covid_lr = Prob(Covid,[],[0.99,0.01])
125
126 p_cough_lr = LogisticRegression(Cough, [Cold,Flu,Covid], [-2.2, 1.67,
127                1.26, 3.19])

```

```

127 p_fever_lr = LogisticRegression(Fever, [ Flu,Covid], [-4.6,      5.02,
128     5.46])
128 p_sneeze_lr = LogisticRegression(Sneeze, [Cold,Flu ], [-2.94, 3.04, 1.79
129     ])
129
130 bn_lr1 = BeliefNetwork("Bipartite Diagnostic Network - logistic
131     regression",
132     {Cough, Fever, Sneeze, Cold, Flu, Covid},
133     {p_cold_lr, p_flu_lr, p_covid_lr, p_cough_lr,
134     p_fever_lr, p_sneeze_lr})
134
135 # to see the conditional probability of Noisy-or do:
136 #print(p_cough_lr.to_table())
137
138 # example from box "Noisy-or compared to logistic regression"
139 # from learnLinear import sigmoid, logit
140 # w0=logit(0.01)
141 # X = Variable("X",boolean)
142 # print(LogisticRegression(X,[A,B,C,D],[w0, logit(0.05)-w0, logit(0.1)-w0,
143     logit(0.2)-w0, logit(0.2)-w0]).to_table(given={X:True}))
144 # try to predict what would happen (and then test) if we had
145 # w0=logit(0.01)

```

## 9.5 Inference Methods

Each of the inference methods implements the query method that computes the posterior probability of a variable given a dictionary of  $\{variable : value\}$  observations. The methods are Displayable because they implement the *display* method which is currently text-based.

```

_____probGraphicalModels.py — (continued)_____
80 from display import Displayable
81 from probExamples import bn_4ch, B, D
82
83 class InferenceMethod(Displayable):
84     """The abstract class of graphical model inference methods"""
85     method_name = "unnamed" # each method should have a method name
86
87     def __init__(self, gm=None):
88         self.gm = gm
89
90     def query(self, qvar, obs={}):
91         """returns a {value:prob} dictionary for the query variable"""
92         raise NotImplementedError("InferenceMethod query") # abstract method

```

We use `bn_4ch` as the test case, in particular  $P(B \mid D = true)$ . This needs an error threshold, particularly for the approximate methods, where the default threshold is much too accurate.

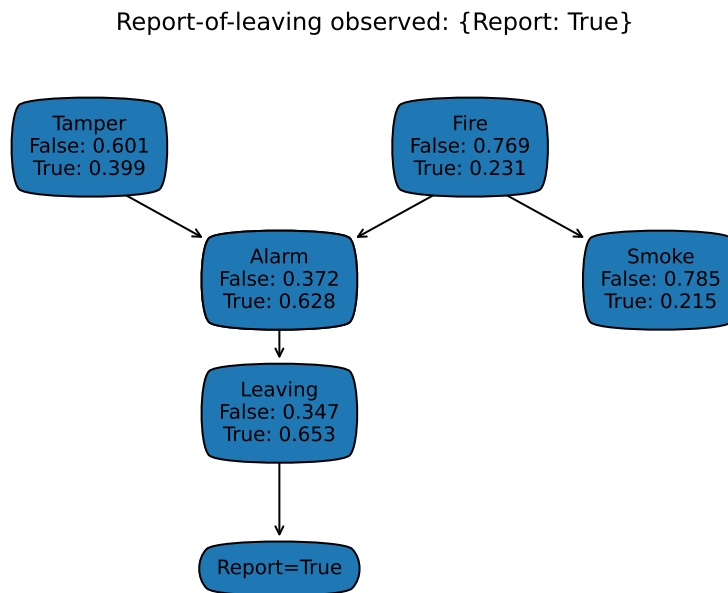

Figure 9.6: The report-of-leaving belief network with posterior distributions

```

_____probGraphicalModels.py — (continued)_____
94 def testIM(self, threshold=0.000000001):
95     solver = self.bn_4ch
96     res = solver.query(B, {D: True})
97     correct_answer = 0.429632380245
98     assert correct_answer - threshold < res[True] <
99           correct_answer + threshold, \
100           f"value {res[True]} not in desired range for
           {self.method_name}"
           print(f"Unit test passed for {self.method_name}.")

```

### 9.5.1 Showing Posterior Distributions

The `show_post` method draws the posterior distribution of all variables. Figure 9.6 shows the result of `bn_reportRC.show_post({Report: True})` when run after loading `probRC.py` (see below).

```

_____probGraphicalModels.py — (continued)_____
102 def show_post(self, obs={}, num_format="{:.3f}", fontsize=10,
103             facecolor='orange'):
104     """draws the graphical model conditioned on observations obs
105     num_format is number format (allows for more or less precision)
           fontsize gives size of the text

```

```

106         facecolor gives the color of the nodes
107         """
108         plt.ion() # interactive
109         ax = plt.figure().gca()
110         ax.set_axis_off()
111         plt.title(self.gm.title+" observed: "+str(obs), fontsize=fontsize)
112         bbox = dict(boxstyle="round4,pad=1.0,rounding_size=0.5",
113                   facecolor=facecolor)
114         vartext = {} # variable:text dictionary
115         for var in self.gm.variables: #reversed(self.gm.topological_sort()):
116             if var in obs:
117                 text = var.name + "=" + str(obs[var])
118             else:
119                 distn = self.query(var, obs=obs)
120
121                 text = var.name + "\n" + "\n".join(str(d)+"\n"+num_format.format(v) for (d,v) in distn.items())
122             vartext[var] = text
123             # Draw arcs
124             for par in self.gm.var2parents[var]:
125                 ax.annotate(text, par.position, xytext=var.position,
126                           arrowprops={'arrowstyle':'<-'},bbox=bbox,
127                                   ha='center', va='center',
128                                   fontsize=fontsize)
129         for var in self.gm.variables:
130             x,y = var.position
131             plt.text(x,y,vartext[var], bbox=bbox, ha='center', va='center',
132                    fontsize=fontsize)

```

## 9.6 Naive Search

An instance of a *ProbSearch* object takes in a graphical model. The query method uses naive search to compute the probability of a query variable given observations on other variables. See Figure 9.9 of Poole and Mackworth [2023].

```

_____probRC.py — Recursive Conditioning for Graphical Models_____
11 import math
12 from probGraphicalModels import GraphicalModel, InferenceMethod
13 from probFactors import Factor
14
15 class ProbSearch(InferenceMethod):
16     """The class that queries graphical models using recursive conditioning
17
18     gm is graphical model to query
19     """
20     method_name = "naive search"
21
22     def __init__(self, gm=None):
23         InferenceMethod.__init__(self, gm)

```

```

24     ## self.max_display_level = 3
25
26     def query(self, qvar, obs={}, split_order=None):
27         """computes P(qvar | obs) where
28         qvar is the query variable
29         obs is a variable:value dictionary
30         split_order is a list of the non-observed non-query variables in gm
31         """
32         if qvar in obs:
33             return {val:(1 if val == obs[qvar] else 0)
34                     for val in qvar.domain}
35         else:
36             if split_order == None:
37                 split_order = [v for v in self.gm.variables
38                               if (v not in obs) and v != qvar]
39             unnorm = [self.prob_search({qvar:val}|obs, self.gm.factors,
40                                     split_order)
41                       for val in qvar.domain]
42             p_obs = sum(unnorm)
43             return {val:pr/p_obs for val,pr in zip(qvar.domain, unnorm)}

```

The following is the naive search-based algorithm. It is exponential in the number of variables, so is not very useful. However, it is simple, and useful to understand before looking at the more complicated algorithm used in the subclass.

probRC.py — (continued)

```

44     def prob_search(self, context, factors, split_order):
45         """simple search algorithm
46         context: a variable:value dictionary
47         factors: a set of factors
48         split_order: list of variables not assigned in context
49         returns sum over variable assignments to variables in split order
50         of product of factors """
51         self.display(2,"calling prob_search,", (context,factors,split_order))
52         if not factors:
53             return 1
54         elif to_eval := {fac for fac in factors
55                         if fac.can_evaluate(context)}:
56             # evaluate factors when all variables are assigned
57             self.display(3,"prob_search evaluating factors",to_eval)
58             val = math.prod(fac.get_value(context) for fac in to_eval)
59             return val * self.prob_search(context, factors-to_eval,
60                                         split_order)
61         else:
62             total = 0
63             var = split_order[0]
64             self.display(3, "prob_search branching on", var)
65             for val in var.domain:
66                 total += self.prob_search({var:val}|context, factors,
67                                         split_order[1:])

```

```

65     self.display(3, "prob_search branching on", var,"returning",
66                 total)
        return total

```

## 9.7 Recursive Conditioning

The **recursive conditioning** algorithm adds forgetting and caching and recognizing disconnected components to the naive search. We do this by adding a cache and redefining the recursive search algorithm. It inherits the query method. See Figure 9.12 of Poole and Mackworth [2023].

```

_____probRC.py — (continued) _____
68 class ProbRC(ProbSearch):
69     method_name = "recursive conditioning"
70
71     def __init__(self, gm=None):
72         self.cache = {(frozenset(), frozenset()):1}
73         ProbSearch.__init__(self, gm)
74
75     def prob_search(self, context, factors, split_order):
76         """ returns \sum_{split_order} \prod_{factors} given assignment in
77             context
78             context is a variable:value dictionary
79             factors is a set of factors
80             split_order: list of variables in factors that are not in context
81             """
82         self.display(3, "calling rc,", (context, factors))
83         ce = (frozenset(context.items()), frozenset(factors)) # key for the
84             cache entry
85         if ce in self.cache:
86             self.display(3, "rc cache lookup", (context, factors))
87             return self.cache[ce]
88         # if not factors: #no factors; not needed with forgetting and caching
89         # return 1
90         elif vars_not_in_factors := {var for var in context
91             if not any(var in fac.variables
92                 for fac in factors)}:
93             # forget variables not in any factor
94             self.display(3, "rc forgetting variables", vars_not_in_factors)
95             return self.prob_search({key:val for (key,val) in
96                 context.items()
97                 if key not in vars_not_in_factors},
98                 factors, split_order)
99         elif to_eval := {fac for fac in factors
100             if fac.can_evaluate(context)}:
101             # evaluate factors when all variables are assigned
102             self.display(3, "rc evaluating factors", to_eval)
103             val = math.prod(fac.get_value(context) for fac in to_eval)
104             if val == 0:

```

```

102         return 0
103     else:
104         return val * self.prob_search(context,
105                                     {fac for fac in factors
106                                     if fac not in to_eval},
107                                     split_order)
108     elif len(comp := connected_components(context, factors,
109                                         split_order)) > 1:
110         # there are disconnected components
111         self.display(3, "splitting into connected components", comp, "in
112         context", context)
113         return(math.prod(self.prob_search(context, f, eo) for (f, eo) in
114                        comp))
115     else:
116         assert split_order, "split_order should not be empty to get
117         here"
118         total = 0
119         var = split_order[0]
120         self.display(3, "rc branching on", var)
121         for val in var.domain:
122             total += self.prob_search({var:val}|context, factors,
123                                     split_order[1:])
124         self.cache[ce] = total
125         self.display(2, "rc branching on", var, "returning", total)
126         return total

```

connected\_components returns a list of connected components, where a connected component is a set of factors and a set of variables, where the graph that connects variables and factors that involve them is connected. The connected components are built one at a time; with a current connected component. At all times factors is partitioned into 3 disjoint sets:

- component\_factors containing factors in the current connected component where all factors that share a variable are already in the component
- factors\_to\_check containing factors in the current connected component where potentially some factors that share a variable are not in the component; these need to be checked
- other\_factors the other factors that are not (yet) in the connected component

probRC.py — (continued)

```

123 def connected_components(context, factors, split_order):
124     """returns a list of (f,e) where f is a subset of factors and e is a
125     subset of split_order
126     such that each element shares the same variables that are disjoint from
127     other elements.
128     """
129     other_factors = set(factors) #copies factors

```

```

128     factors_to_check = {other_factors.pop()} # factors in connected
        component still to be checked
129     component_factors = set() # factors in first connected component
        already checked
130     component_variables = set() # variables in first connected component
131     while factors_to_check:
132         next_fac = factors_to_check.pop()
133         component_factors.add(next_fac)
134         new_vars = set(next_fac.variables) - component_variables -
            context.keys()
135         component_variables |= new_vars
136         for var in new_vars:
137             factors_to_check |= {f for f in other_factors
                if var in f.variables}
138             other_factors -= factors_to_check # set difference
139     if other_factors:
140         return ( [(component_factors,[e for e in split_order
                if e in component_variables])]
141                 + connected_components(context, other_factors,
                [e for e in split_order
                if e not in component_variables]) )
142     else:
143         return [(component_factors, split_order)]
144
145
146
147

```

Testing:

```

_____probRC.py — (continued)_____
149 from probExamples import bn_4ch, A,B,C,D,f_a,f_b,f_c,f_d
150 bn_4chv = ProbRC(bn_4ch)
151 ## bn_4chv.query(A,{})
152 ## bn_4chv.query(D,{})
153 ## InferenceMethod.max_display_level = 3 # show more detail in displaying
154 ## InferenceMethod.max_display_level = 1 # show less detail in displaying
155 ## bn_4chv.query(A,{D:True},[C,B])
156 ## bn_4chv.query(B,{A:True,D:False})
157
158 from probExamples import bn_report,Alarm,Fire,Leaving,Report,Smoke,Tamper
159 bn_reportRC = ProbRC(bn_report) # answers queries using recursive
        conditioning
160 ## bn_reportRC.query(Tamper,{})
161 ## InferenceMethod.max_display_level = 0 # show no detail in displaying
162 ## bn_reportRC.query(Leaving,{})
163 ## bn_reportRC.query(Tamper,{},
        split_order=[Smoke,Fire,Alarm,Leaving,Report])
164 ## bn_reportRC.query(Tamper,{Report:True})
165 ## bn_reportRC.query(Tamper,{Report:True,Smoke:False})
166
167 ## To display resulting posteriors try:
168 # bn_reportRC.show_post({})
169 # bn_reportRC.show_post({Smoke:False})
170 # bn_reportRC.show_post({Report:True})

```

```

171 # bn_reportRC.show_post({Report:True, Smoke:False})
172
173 ## Note what happens to the cache when these are called in turn:
174 ## bn_reportRC.query(Tamper,{Report:True},
    split_order=[Smoke,Fire,Alarm,Leaving])
175 ## bn_reportRC.query(Smoke,{Report:True},
    split_order=[Tamper,Fire,Alarm,Leaving])
176
177 from probExamples import bn_sprinkler, Season, Sprinkler, Rained,
    Grass_wet, Grass_shiny, Shoes_wet
178 bn_sprinklerv = ProbRC(bn_sprinkler)
179 ## bn_sprinklerv.query(Shoes_wet,{})
180 ## bn_sprinklerv.query(Shoes_wet,{Rained:True})
181 ## bn_sprinklerv.query(Shoes_wet,{Grass_shiny:True})
182 ## bn_sprinklerv.query(Shoes_wet,{Grass_shiny:False,Rained:True})
183
184 from probExamples import bn_no1, bn_lr1, Cough, Fever, Sneeze, Cold, Flu,
    Covid
185 bn_no1v = ProbRC(bn_no1)
186 bn_lr1v = ProbRC(bn_lr1)
187 ## bn_no1v.query(Flu, {Fever:1, Sneeze:1})
188 ## bn_lr1v.query(Flu, {Fever:1, Sneeze:1})
189 ## bn_lr1v.query(Cough,{})
190 ## bn_lr1v.query(Cold,{Cough:1,Sneeze:0,Fever:1})
191 ## bn_lr1v.query(Flu,{Cough:0,Sneeze:1,Fever:1})
192 ## bn_lr1v.query(Covid,{Cough:1,Sneeze:0,Fever:1})
193 ## bn_lr1v.query(Covid,{Cough:1,Sneeze:0,Fever:1,Flu:0})
194 ## bn_lr1v.query(Covid,{Cough:1,Sneeze:0,Fever:1,Flu:1})
195
196 if __name__ == "__main__":
197     InferenceMethod.testIM(ProbSearch)
198     InferenceMethod.testIM(ProbRC)

```

The following example uses the decision tree representation of Section 9.3.4 (page 207). Does recursive conditioning split on variable full for the query commented out below? What can be done to guarantee that it does?

```

_____probRC.py — (continued)_____
200 from probFactors import Prob, action, rain, full, wet, p_wet
201 from probGraphicalModels import BeliefNetwork
202 p_action = Prob(action,[],{'go_out':0.3, 'get_coffee':0.7})
203 p_rain = Prob(rain,[],[0.4,0.6])
204 p_full = Prob(full,[],[0.1,0.9])
205
206 wetBN = BeliefNetwork("Wet (decision tree CPD)", {action, rain, full, wet},
207                {p_action, p_rain, p_full, p_wet})
208 wetRC = ProbRC(wetBN)
209 # wetRC.query(wet, {action:'go_out', rain:True})
210 # wetRC.show_post({action:'go_out', rain:True})
211 # wetRC.show_post({action:'go_out', wet:True})

```

## 9.8 Variable Elimination

An instance of a *VE* object takes in a graphical model. The query method uses variable elimination to compute the probability of a variable given observations on some other variables.

```

probVE.py — Variable Elimination for Graphical Models
11 from probFactors import Factor, FactorObserved, FactorSum, factor_times
12 from probGraphicalModels import GraphicalModel, InferenceMethod
13
14 class VE(InferenceMethod):
15     """The class that queries Graphical Models using variable elimination.
16
17     gm is graphical model to query
18     """
19     method_name = "variable elimination"
20
21     def __init__(self, gm=None):
22         InferenceMethod.__init__(self, gm)
23
24     def query(self, var, obs={}, elim_order=None):
25         """computes P(var|obs) where
26         var is a variable
27         obs is a {variable:value} dictionary"""
28         if var in obs:
29             return {var:1 if val == obs[var] else 0 for val in var.domain}
30         else:
31             if elim_order == None:
32                 elim_order = self.gm.variables
33             projFactors = [self.project_observations(fact, obs)
34                           for fact in self.gm.factors]
35             for v in elim_order:
36                 if v != var and v not in obs:
37                     projFactors = self.eliminate_var(projFactors, v)
38             unnorm = factor_times(var, projFactors)
39             p_obs = sum(unnorm)
40             self.display(1, "Unnormalized probs:", unnorm, "Prob obs:", p_obs)
41             return {val:pr/p_obs for val, pr in zip(var.domain, unnorm)}

```

A *FactorObserved* is a factor that is the result of some observations on another factor. We don't store the values in a list; we just look them up as needed. The observations can include variables that are not in the list, but should have some intersection with the variables in the factor.

```

probFactors.py — (continued)
221 class FactorObserved(Factor):
222     def __init__(self, factor, obs):
223         Factor.__init__(self, [v for v in factor.variables if v not in obs])
224         self.observed = obs
225         self.orig_factor = factor
226

```

```

227 |     def get_value(self, assignment):
228 |         return self.orig_factor.get_value(assignment|self.assigned)

```

A *FactorSum* is a factor that is the result of summing out a variable from the product of other factors. I.e., it constructs a representation of:

$$\sum_{var} \prod_{f \in factors} f.$$

We store the values in a list in a lazy manner; if they are already computed, we used the stored values. If they are not already computed we can compute and store them.

---

probFactors.py — (continued)

```

230 | class FactorSum(Factor):
231 |     def __init__(self, var, factors):
232 |         self.var_summed_out = var
233 |         self.factors = factors
234 |         vars = list({v for fac in factors
235 |                     for v in fac.variables if v is not var})
236 |         #for fac in factors:
237 |         #    for v in fac.variables:
238 |         #        if v is not var and v not in vars:
239 |         #            vars.append(v)
240 |         Factor.__init__(self, vars)
241 |         self.values = {}
242 |
243 |     def get_value(self, assignment):
244 |         """lazy implementation: if not saved, compute it. Return saved
245 |            value"""
246 |         asst = frozenset(assignment.items())
247 |         if asst in self.values:
248 |             return self.values[asst]
249 |         else:
250 |             total = 0
251 |             new_asst = assignment.copy()
252 |             for val in self.var_summed_out.domain:
253 |                 new_asst[self.var_summed_out] = val
254 |                 total += math.prod(fac.get_value(new_asst) for fac in
255 |                                   self.factors)
256 |             self.values[asst] = total
257 |         return total

```

The method *factor\_times* multiplies a set of factors that are all factors on the same variable (or on no variables). This is the last step in variable elimination before normalizing. It returns an array giving the product for each value of *variable*.

---

probFactors.py — (continued)

```

257 | def factor_times(variable, factors):
258 |     """when factors are factors just on variable (or on no variables)"""
259 |     prods = []

```

```

260     facts = [f for f in factors if variable in f.variables]
261     for val in variable.domain:
262         ast = {variable:val}
263         prods.append(math.prod(f.get_value(ast) for f in facts))
264     return prods

```

To project observations onto a factor, for each variable that is observed in the factor, we construct a new factor that is the factor projected onto that variable. *Factor\_observed* creates a new factor that is the result of assigning a value to a single variable.

```

_____probVE.py — (continued)_____
43     def project_observations(self, factor, obs):
44         """Returns the resulting factor after observing obs
45
46         obs is a dictionary of {variable:value} pairs.
47         """
48         if any((var in obs) for var in factor.variables):
49             # a variable in factor is observed
50             return FactorObserved(factor, obs)
51         else:
52             return factor
53
54     def eliminate_var(self, factors, var):
55         """Eliminate a variable var from a list of factors.
56         Returns a new set of factors that has var summed out.
57         """
58         self.display(2, "eliminating ", str(var))
59         contains_var = []
60         not_contains_var = []
61         for fac in factors:
62             if var in fac.variables:
63                 contains_var.append(fac)
64             else:
65                 not_contains_var.append(fac)
66         if contains_var == []:
67             return factors
68         else:
69             newFactor = FactorSum(var, contains_var)
70             self.display(2, "Multiplying:", [str(f) for f in contains_var])
71             self.display(2, "Creating factor:", newFactor)
72             self.display(3, newFactor.to_table()) # factor in detail
73             not_contains_var.append(newFactor)
74             return not_contains_var
75
76     from probExamples import bn_4ch, A, B, C, D
77     bn_4chv = VE(bn_4ch)
78     ## bn_4chv.query(A, {})
79     ## bn_4chv.query(D, {})
80     ## InferenceMethod.max_display_level = 3 # show more detail in displaying
81     ## InferenceMethod.max_display_level = 1 # show less detail in displaying

```

```

82  ## bn_4chv.query(A,{D:True})
83  ## bn_4chv.query(B,{A:True,D:False})
84
85  from probExamples import bn_report,Alarm,Fire,Leaving,Report,Smoke,Tamper
86  bn_reportv = VE(bn_report) # answers queries using variable elimination
87  ## bn_reportv.query(Tamper,{})
88  ## InferenceMethod.max_display_level = 0 # show no detail in displaying
89  ## bn_reportv.query(Leaving,{})
90  ## bn_reportv.query(Tamper,{},elim_order=[Smoke,Report,Leaving,Alarm,Fire])
91  ## bn_reportv.query(Tamper,{Report:True})
92  ## bn_reportv.query(Tamper,{Report:True,Smoke:False})
93
94  from probExamples import bn_sprinkler, Season, Sprinkler, Rained,
    Grass_wet, Grass_shiny, Shoes_wet
95  bn_sprinklerv = VE(bn_sprinkler)
96  ## bn_sprinklerv.query(Shoes_wet,{})
97  ## bn_sprinklerv.query(Shoes_wet,{Rained:True})
98  ## bn_sprinklerv.query(Shoes_wet,{Grass_shiny:True})
99  ## bn_sprinklerv.query(Shoes_wet,{Grass_shiny:False,Rained:True})
100
101  from probExamples import bn_lr1, Cough, Fever, Sneeze, Cold, Flu, Covid
102  vediag = VE(bn_lr1)
103  ## vediag.query(Cough,{})
104  ## vediag.query(Cold,{Cough:1,Sneeze:0,Fever:1})
105  ## vediag.query(Flu,{Cough:0,Sneeze:1,Fever:1})
106  ## vediag.query(Covid,{Cough:1,Sneeze:0,Fever:1})
107  ## vediag.query(Covid,{Cough:1,Sneeze:0,Fever:1,Flu:0})
108  ## vediag.query(Covid,{Cough:1,Sneeze:0,Fever:1,Flu:1})
109
110  if __name__ == "__main__":
111      InferenceMethod.testIM(VE)

```

## 9.9 Stochastic Simulation

### 9.9.1 Sampling from a discrete distribution

The method *sample\_one* generates a single sample from a (possible unnormalized) distribution. *dist* is a  $\{value : weight\}$  dictionary, where  $weight \geq 0$ . This returns a value with probability in proportion to its weight.

```

_____probStochSim.py — Probabilistic inference using stochastic simulation_____
11  import random
12  from probGraphicalModels import InferenceMethod
13
14  def sample_one(dist):
15      """returns the index of a single sample from normalized distribution
    dist."""
16      rand = random.random()*sum(dist.values())
17      cum = 0 # cumulative weights

```

```

18 |     for v in dist:
19 |         cum += dist[v]
20 |         if cum > rand:
21 |             return v

```

If we want to generate multiple samples, repeatedly calling *sample\_one* may not be efficient. If we want to generate  $n$  samples, and the distribution is over  $m$  values, *sample\_one* takes time  $O(mn)$ . If  $m$  and  $n$  are of the same order of magnitude, we can do better.

The method *sample\_multiple* generates multiple samples from a distribution defined by *dist*, where *dist* is a  $\{value : weight\}$  dictionary, where  $weight \geq 0$  and the weights cannot all be zero. This returns a list of values, of length *num\_samples*, where each sample is selected with a probability proportional to its weight.

The method generates all of the random numbers, sorts them, and then goes through the distribution once, saving the selected samples.

```

_____probStochSim.py — (continued)_____
23 | def sample_multiple(dist, num_samples):
24 |     """returns a list of num_samples values selected using distribution
    |     dist.
25 |     dist is a {value:weight} dictionary that does not need to be normalized
    |     """
26 |
27 |     total = sum(dist.values())
28 |     rands = sorted(random.random()*total for i in range(num_samples))
29 |     result = []
30 |     dist_items = list(dist.items())
31 |     cum = dist_items[0][1] # cumulative sum
32 |     index = 0
33 |     for r in rands:
34 |         while r>cum:
35 |             index += 1
36 |             cum += dist_items[index][1]
37 |             result.append(dist_items[index][0])
38 |     return result

```

### Exercise 9.1

What is the time and space complexity the following 4 methods to generate  $n$  samples, where  $m$  is the length of *dist*:

- $n$  calls to *sample\_one*
- sample\_multiple*
- Create the cumulative distribution (choose how this is represented) and, for each random number, do a binary search to determine the sample associated with the random number.
- Choose a random number in the range  $[i/n, (i + 1)/n)$  for each  $i \in \text{range}(n)$ , where  $n$  is the number of samples. Use these as the random numbers to select the particles. (Does this give random samples?)

For each method suggest when it might be the best method.

The *test\_sampling* method can be used to generate the statistics from a number of samples. It is useful to see the variability as a function of the number of samples. Try it for few samples and also for many samples.

```

_____probStochSim.py — (continued) _____
40 def test_sampling(dist, num_samples):
41     """Given a distribution, dist, draw num_samples samples
42     and return the resulting counts
43     """
44     result = {v:0 for v in dist}
45     for v in sample_multiple(dist, num_samples):
46         result[v] += 1
47     return result
48
49 # try the following queries a number of times each:
50 # test_sampling({1:1,2:2,3:3,4:4}, 100)
51 # test_sampling({1:1,2:2,3:3,4:4}, 100000)

```

### 9.9.2 Sampling Methods for Belief Network Inference

A *SamplingInferenceMethod* is an *InferenceMethod*, but the query method also takes arguments for the number of samples and the sample-order (which is an ordering of factors). The first methods assume a belief network (and not an undirected graphical model).

```

_____probStochSim.py — (continued) _____
53 class SamplingInferenceMethod(InferenceMethod):
54     """The abstract class of sampling-based belief network inference
55     methods"""
56
57     def __init__(self, gm=None):
58         InferenceMethod.__init__(self, gm)
59
60     def query(self, qvar, obs={}, number_samples=1000, sample_order=None):
61         raise NotImplementedError("SamplingInferenceMethod query") #
62         abstract

```

### 9.9.3 Rejection Sampling

```

_____probStochSim.py — (continued) _____
62 class RejectionSampling(SamplingInferenceMethod):
63     """The class that queries Graphical Models using Rejection Sampling.
64
65     gm is a belief network to query
66     """
67     method_name = "rejection sampling"

```

```

68
69     def __init__(self, gm=None):
70         SamplingInferenceMethod.__init__(self, gm)
71
72     def query(self, qvar, obs={}, number_samples=1000, sample_order=None):
73         """computes P(qvar | obs) where
74         qvar is a variable.
75         obs is a {variable:value} dictionary.
76         sample_order is a list of variables where the parents
77         come before the variable.
78         """
79         if sample_order is None:
80             sample_order = self.gm.topological_sort()
81         self.display(2, *sample_order, sep="\t")
82         counts = {val:0 for val in qvar.domain}
83         for i in range(number_samples):
84             rejected = False
85             sample = {}
86             for nvar in sample_order:
87                 fac = self.gm.var2cpt[nvar] #factor with nvar as child
88                 val = sample_one({v:fac.get_value(**sample, nvar:v)} for v
89                                 in nvar.domain})
90                 self.display(2, val, end="\t")
91                 if nvar in obs and obs[nvar] != val:
92                     rejected = True
93                     self.display(2, "Rejected")
94                     break
95                 sample[nvar] = val
96             if not rejected:
97                 counts[sample[qvar]] += 1
98                 self.display(2, "Accepted")
99         tot = sum(counts.values())
100        # As well as the distribution we also include raw counts
101        dist = {c:v/tot if tot>0 else 1/len(qvar.domain) for (c,v) in
102               counts.items()}
103        dist["raw_counts"] = counts
104        return dist

```

### 9.9.4 Likelihood Weighting

Likelihood weighting includes a weight for each sample. Instead of rejecting samples based on observations, likelihood weighting changes the weights of the sample in proportion with the probability of the observation. The weight then becomes the probability that the variable would have been rejected.

```

_____probStochSim.py — (continued)_____
104 class LikelihoodWeighting(SamplingInferenceMethod):
105     """The class that queries Graphical Models using Likelihood weighting.
106
107     gm is a belief network to query
108     """

```

```

109     method_name = "likelihood weighting"
110
111     def __init__(self, gm=None):
112         SamplingInferenceMethod.__init__(self, gm)
113
114     def query(self, qvar, obs={}, number_samples=1000, sample_order=None):
115         """computes P(qvar | obs) where
116         qvar is a variable.
117         obs is a {variable:value} dictionary.
118         sample_order is a list of factors where factors defining the parents
119         come before the factors for the child.
120         """
121         if sample_order is None:
122             sample_order = self.gm.topological_sort()
123         self.display(2, *[v for v in sample_order
124                          if v not in obs], sep="\t")
125         counts = {val:0 for val in qvar.domain}
126         for i in range(number_samples):
127             sample = {}
128             weight = 1.0
129             for nvar in sample_order:
130                 fac = self.gm.var2cpt[nvar]
131                 if nvar in obs:
132                     sample[nvar] = obs[nvar]
133                     weight *= fac.get_value(sample)
134                 else:
135                     val = sample_one({v:fac.get_value(**sample, nvar:v)} for
136                                     v in nvar.domain)
137                     self.display(2, val, end="\t")
138                     sample[nvar] = val
139             counts[sample[qvar]] += weight
140             self.display(2, weight)
141         tot = sum(counts.values())
142         # as well as the distribution we also include the raw counts
143         dist = {c:v/tot for (c,v) in counts.items()}
144         dist["raw_counts"] = counts
145         return dist

```

**Exercise 9.2** Change this algorithm so that it does **importance sampling** using a proposal distribution. It needs *sample\_one* using a different distribution and then update the weight of the current sample. For testing, use a proposal distribution that only specifies probabilities for some of the variables (and the algorithm uses the probabilities for the network in other cases).

### 9.9.5 Particle Filtering

In this implementation, a particle is a  $\{variable : value\}$  dictionary. Because adding a new value to dictionary involves a side effect, the dictionaries need to be copied during resampling.

```

probStochSim.py — (continued)
146 class ParticleFiltering(SamplingInferenceMethod):
147     """The class that queries Graphical Models using Particle Filtering.
148
149     gm is a belief network to query
150     """
151     method_name = "particle filtering"
152
153     def __init__(self, gm=None):
154         SamplingInferenceMethod.__init__(self, gm)
155
156     def query(self, qvar, obs={}, number_samples=1000, sample_order=None):
157         """computes P(qvar | obs) where
158         qvar is a variable.
159         obs is a {variable:value} dictionary.
160         sample_order is a list of factors where factors defining the parents
161         come before the factors for the child.
162         """
163         if sample_order is None:
164             sample_order = self.gm.topological_sort()
165         self.display(2,*[v for v in sample_order
166                        if v not in obs],sep="\t")
167         particles = [{i} for i in range(number_samples)]
168         for nvar in sample_order:
169             fac = self.gm.var2cpt[nvar]
170             if nvar in obs:
171                 weights = [fac.get_value(**part, nvar:obs[nvar])]
172                 for part in particles]
173                 particles = [{*p, nvar:obs[nvar]}
174                             for p in resample(particles, weights,
175                                               number_samples)]
176             else:
177                 for part in particles:
178                     part[nvar] = sample_one({v:fac.get_value(**part,
179                                                             nvar:v)}
180                                             for v in nvar.domain})
181                     self.display(2,part[nvar],end="\t")
182         counts = {val:0 for val in qvar.domain}
183         for part in particles:
184             counts[part[qvar]] += 1
185         tot = sum(counts.values())
186         # as well as the distribution we also include the raw counts
187         dist = {c:v/tot for (c,v) in counts.items()}
188         dist["raw_counts"] = counts
189         return dist

```

## Resampling

Resample is based on *sample\_multiple* but works with an array of particles. (Aside: Python doesn't let us use *sample\_multiple* directly as it uses a dictionary,

and particles, represented as dictionaries can't be the key of dictionaries).

```

_____probStochSim.py — (continued)_____
189 def resample(particles, weights, num_samples):
190     """returns num_samples copies of particles resampled according to
        weights.
191     particles is a list of particles
192     weights is a list of positive numbers, of same length as particles
193     num_samples is n integer
194     """
195     total = sum(weights)
196     rands = sorted(random.random()*total for i in range(num_samples))
197     result = []
198     cum = weights[0] # cumulative sum
199     index = 0
200     for r in rands:
201         while r>cum:
202             index += 1
203             cum += weights[index]
204         result.append(particles[index])
205     return result

```

### 9.9.6 Examples

```

_____probStochSim.py — (continued)_____
207 from probExamples import bn_4ch, A,B,C,D
208 bn_4chr = RejectionSampling(bn_4ch)
209 bn_4chL = LikelihoodWeighting(bn_4ch)
210 ## InferenceMethod.max_display_level = 2 # detailed tracing for all
        inference methods
211 ## bn_4chr.query(A, {})
212 ## bn_4chr.query(C, {})
213 ## bn_4chr.query(A, {C:True})
214 ## bn_4chr.query(B, {A:True,C:False})
215
216 from probExamples import bn_report,Alarm,Fire,Leaving,Report,Smoke,Tamper
217 bn_reportr = RejectionSampling(bn_report) # answers queries using
        rejection sampling
218 bn_reportL = LikelihoodWeighting(bn_report) # answers queries using
        likelihood weighting
219 bn_reportp = ParticleFiltering(bn_report) # answers queries using particle
        filtering
220 ## bn_reportr.query(Tamper, {})
221 ## bn_reportr.query(Tamper, {})
222 ## bn_reportr.query(Tamper, {Report:True})
223 ## InferenceMethod.max_display_level = 0 # no detailed tracing for all
        inference methods
224 ## bn_reportr.query(Tamper, {Report:True}, number_samples=100000)
225 ## bn_reportr.query(Tamper, {Report:True, Smoke:False})

```

```

226 ## bn_reportr.query(Tamper,{Report:True,Smoke:False},number_samples=100)
227
228 ## bn_reportL.query(Tamper,{Report:True,Smoke:False},number_samples=100)
229 ## bn_reportL.query(Tamper,{Report:True,Smoke:False},number_samples=100)
230
231 from probExamples import bn_sprinkler,Season, Sprinkler
232 from probExamples import Rained, Grass_wet, Grass_shiny, Shoes_wet
233 bn_sprinklerr = RejectionSampling(bn_sprinkler) # answers queries using
      rejection sampling
234 bn_sprinklerL = LikelihoodWeighting(bn_sprinkler) # answers queries using
      rejection sampling
235 bn_sprinklerp = ParticleFiltering(bn_sprinkler) # answers queries using
      particle filtering
236 #bn_sprinklerr.query(Shoes_wet,{Grass_shiny:True,Rained:True})
237 #bn_sprinklerL.query(Shoes_wet,{Grass_shiny:True,Rained:True})
238 #bn_sprinklerp.query(Shoes_wet,{Grass_shiny:True,Rained:True})
239
240 if __name__ == "__main__":
241     InferenceMethod.testIM(RejectionSampling, threshold=0.1)
242     InferenceMethod.testIM(LikelihoodWeighting, threshold=0.1)
243     InferenceMethod.testIM(ParticleFiltering, threshold=0.1)

```

**Exercise 9.3** This code keeps regenerating the distribution of a variable given its parents. Implement one or both of the following, and compare them to the original. Make *cond\_dist* return a slice that corresponds to the distribution, and then use the slice instead of the dictionary (a list slice does not generate new data structures). Make *cond\_dist* remember values it has already computed, and only return these.

### 9.9.7 Gibbs Sampling

The following implements **Gibbs sampling**, a form of **Markov Chain Monte Carlo MCMC**.

```

_____probStochSim.py — (continued)_____
245 #import random
246 #from probGraphicalModels import InferenceMethod
247
248 #from probStochSim import sample_one, SamplingInferenceMethod
249
250 class GibbsSampling(SamplingInferenceMethod):
251     """The class that queries Graphical Models using Gibbs Sampling.
252
253     bn is a graphical model (e.g., a belief network) to query
254     """
255     method_name = "Gibbs sampling"
256
257     def __init__(self, gm=None):
258         SamplingInferenceMethod.__init__(self, gm)
259         self.gm = gm

```

```

260
261 def query(self, qvar, obs={}, number_samples=1000, burn_in=100,
262         sample_order=None):
263     """computes P(qvar | obs) where
264     qvar is a variable.
265     obs is a {variable:value} dictionary.
266     sample_order is a list of non-observed variables in order, or
267     if sample_order None, an arbitrary ordering is used
268     """
269     counts = {val:0 for val in qvar.domain}
270     if sample_order is not None:
271         variables = sample_order
272     else:
273         variables = [v for v in self.gm.variables if v not in obs]
274         random.shuffle(variables)
275     var_to_factors = {v:set() for v in self.gm.variables}
276     for fac in self.gm.factors:
277         for var in fac.variables:
278             var_to_factors[var].add(fac)
279     sample = {var:random.choice(var.domain) for var in variables}
280     self.display(3,"Sample:",sample)
281     sample.update(obs)
282     for i in range(burn_in + number_samples):
283         for var in variables:
284             # get unnormalized probability distribution of var given its
285             # neighbors
286             vardist = {val:1 for val in var.domain}
287             for val in var.domain:
288                 sample[var] = val
289                 for fac in var_to_factors[var]: # Markov blanket
290                     vardist[val] *= fac.get_value(sample)
291                 sample[var] = sample_one(vardist)
292             if i >= burn_in:
293                 counts[sample[qvar]] +=1
294                 self.display(3,"      ",sample)
295         tot = sum(counts.values())
296         # as well as the computed distribution, we also include raw counts
297         dist = {c:v/tot for (c,v) in counts.items()}
298         dist["raw_counts"] = counts
299         self.display(2, f"Gibbs sampling P({qvar}|{obs}) = {dist}")
300     return dist
301
302 #from probExamples import bn_4ch, A,B,C,D
303 bn_4chg = GibbsSampling(bn_4ch)
304 ## InferenceMethod.max_display_level = 2 # detailed tracing for all
305 inference methods
306 bn_4chg.query(A,{})
307 ## bn_4chg.query(D,{})
308 ## bn_4chg.query(B,{D:True})
309 ## bn_4chg.query(B,{A:True,C:False})

```

```

307
308 from probExamples import bn_report, Alarm, Fire, Leaving, Report, Smoke, Tamper
309 bn_reportg = GibbsSampling(bn_report)
310 ## bn_reportg.query(Tamper, {Report: True}, number_samples=1000)
311
312 if __name__ == "__main__":
313     InferenceMethod.testIM(GibbsSampling, threshold=0.1)

```

**Exercise 9.4** Change the code so that it can have multiple query variables. Make the list of query variable be an input to the algorithm, so that the default value is the list of all non-observed variables.

**Exercise 9.5** In this algorithm, explain where it computes the probability of a variable given its Markov blanket. Instead of returning the average of the samples for the query variable, it is possible to return the average estimate of the probability of the query variable given its Markov blanket. Does this converge to the same answer as the given code? Does it converge faster, slower, or the same?

### 9.9.8 Plotting Behavior of Stochastic Simulators

The stochastic simulation runs can give different answers each time they are run. For the algorithms that give the same answer in the limit as the number of samples approaches infinity (as do all of these algorithms), the algorithms can be compared by comparing the accuracy for multiple runs. Summary statistics like the variance may provide some information, but the assumptions behind the variance being appropriate (namely that the distribution is approximately Gaussian) may not hold for cases where the predictions are bounded and often skewed.

It is more appropriate to plot the distribution of predictions over multiple runs. The `plot_stats` method plots the prediction of a particular variable (or for the partition function) for a number of runs of the same algorithm. On the  $x$ -axis, is the prediction of the algorithm. On the  $y$ -axis is the number of runs with prediction less than or equal to the  $x$  value. Thus this is like a cumulative distribution over the predictions, but with counts on the  $y$ -axis.

Note that for runs where there are no samples that are consistent with the observations (as can happen with rejection sampling), the prediction of probability is 1.0 (as a convention for 0/0).

That variable *what* contains the query variable, or *what* is “*prob\_ev*”, the probability of evidence.

```

----- probStochSim.py — (continued) -----
315 import matplotlib.pyplot as plt
316
317 def plot_stats(method, qvar, qval, obs, number_runs=1000, **queryargs):
318     """Plots a cumulative distribution of the prediction of the model.
319     method is a InferenceMethod (that implements appropriate query())
320     plots P(qvar=qval | obs)
321     qvar is the query variable, qval is corresponding value

```

```

322     obs is the {variable:value} dictionary representing the observations
323     number_iterations is the number of runs that are plotted
324     **queryargs is the arguments to query (often number_samples for
           sampling methods)
325     """
326     plt.ion()
327     plt.xlabel("value")
328     plt.ylabel("Cumulative Number")
329     method.max_display_level, prev_mdl = 0, method.max_display_level #no
           display
330     answers = [method.query(qvar, obs, **queryargs)
331                for i in range(number_runs)]
332     values = [ans[qval] for ans in answers]
333     label = f"""{method.method_name}
           P({qvar}={qval}|{' , '.join(f'{var}={val}'
334                                     for (var, val) in
                                     obs.items())}"""
335     values.sort()
336     plt.plot(values, range(number_runs), label=label)
337     plt.legend() #loc="upper left")
338     plt.draw()
339     method.max_display_level = prev_mdl # restore display level
340
341 # Try:
342 # plot_stats(bn_reportr, Tamper, True, {Report: True, Smoke: True},
           number_samples=1000, number_runs=1000)
343 # plot_stats(bn_reportL, Tamper, True, {Report: True, Smoke: True},
           number_samples=1000, number_runs=1000)
344 # plot_stats(bn_reportp, Tamper, True, {Report: True, Smoke: True},
           number_samples=1000, number_runs=1000)
345 # plot_stats(bn_reportr, Tamper, True, {Report: True, Smoke: True},
           number_samples=100, number_runs=1000)
346 # plot_stats(bn_reportL, Tamper, True, {Report: True, Smoke: True},
           number_samples=100, number_runs=1000)
347 # plot_stats(bn_reportg, Tamper, True, {Report: True, Smoke: True},
           number_samples=1000, number_runs=1000)
348
349 def plot_mult(methods, example, qvar, qval, obs, number_samples=1000,
           number_runs=1000):
350     for method in methods:
351         solver = method(example)
352         if isinstance(method, SamplingInferenceMethod):
353             plot_stats(solver, qvar, qval, obs,
                 number_samples=number_samples, number_runs=number_runs)
354         else:
355             plot_stats(solver, qvar, qval, obs, number_runs=number_runs)
356
357 from probRC import ProbRC
358 # Try following (but it takes a while..)
359 methods =

```

```

    [ProbRC,RejectionSampling,LikelihoodWeighting,ParticleFiltering,GibbsSampling]
360 #plot_mult(methods,bn_report,Tamper,True,{Report:True,Smoke:False},number_samples=100,
    number_runs=1000)
361 #
    plot_mult(methods,bn_report,Tamper,True,{Report:False,Smoke:True},number_samples=100,
    number_runs=1000)
362
363 # Sprinkler Example:
364 #
    plot_stats(bn_sprinklerr,Shoes_wet,True,{Grass_shiny:True,Rained:True},number_samples=1000)
365 #
    plot_stats(bn_sprinklerL,Shoes_wet,True,{Grass_shiny:True,Rained:True},number_samples=1000)

```

## 9.10 Hidden Markov Models

This code for hidden Markov models is independent of the graphical models code, to keep it simple. Section 9.11 gives code that models hidden Markov models, and more generally, dynamic belief networks, using the graphical models code.

This HMM code assumes there are multiple Boolean observation variables that depend on the current state and are independent of each other given the state.

```

_____probHMM.py — Hidden Markov Model_____
11 import random
12 from probStochSim import sample_one, sample_multiple
13
14 class HMM(object):
15     def __init__(self, states, obsvars, pobs, trans, indist):
16         """A hidden Markov model.
17         states - set of states
18         obsvars - set of observation variables
19         pobs - probability of observations, pobs[i][s] is P(Obs_i=True |
                State=s)
20         trans - transition probability - trans[i][j] gives P(State=j |
                State=i)
21         indist - initial distribution - indist[s] is P(State_0 = s)
22         """
23         self.states = states
24         self.obsvars = obsvars
25         self.pobs = pobs
26         self.trans = trans
27         self.indist = indist

```

Consider the following example. Suppose you want to unobtrusively keep track of an animal in a triangular enclosure using sound. Suppose you have 3 microphones that provide unreliable (noisy) binary information at each time

step. The animal is either close to one of the 3 points of the triangle or in the middle of the triangle.

```

_____probHMM.py — (continued)_____
29 # state
30 #     0=middle, 1,2,3 are corners
31 states1 = {'middle', 'c1', 'c2', 'c3'} # states
32 obs1 = {'m1', 'm2', 'm3'} # microphones

```

The observation model is as follows. If the animal is in a corner, it will be detected by the microphone at that corner with probability 0.6, and will be independently detected by each of the other microphones with a probability of 0.1. If the animal is in the middle, it will be detected by each microphone with a probability of 0.4.

```

_____probHMM.py — (continued)_____
34 # pobs gives the observation model:
35 #pobs[mi][state] is P(mi=on | state)
36 closeMic=0.6; farMic=0.1; midMic=0.4
37 pobs1 = {'m1':{'middle':midMic, 'c1':closeMic, 'c2':farMic, 'c3':farMic},
          # mic 1
38         'm2':{'middle':midMic, 'c1':farMic, 'c2':closeMic, 'c3':farMic}, #
          mic 2
39         'm3':{'middle':midMic, 'c1':farMic, 'c2':farMic, 'c3':closeMic}} #
          mic 3

```

The transition model is as follows: If the animal is in a corner it stays in the same corner with probability 0.80, goes to the middle with probability 0.1 or goes to one of the other corners with probability 0.05 each. If it is in the middle, it stays in the middle with probability 0.7, otherwise it moves to one the corners, each with probability 0.1.

```

_____probHMM.py — (continued)_____
41 # trans specifies the dynamics
42 # trans[i] is the distribution over states resulting from state i
43 # trans[i][j] gives P(S=j | S=i)
44 sm=0.7; mmc=0.1 # transition probabilities when in middle
45 sc=0.8; mcm=0.1; mcc=0.05 # transition probabilities when in a corner
46 trans1 = {'middle':{'middle':sm, 'c1':mmc, 'c2':mmc, 'c3':mmc}, # was in
          middle
47         'c1':{'middle':mcm, 'c1':sc, 'c2':mcc, 'c3':mcc}, # was in corner
          1
48         'c2':{'middle':mcm, 'c1':mcc, 'c2':sc, 'c3':mcc}, # was in corner
          2
49         'c3':{'middle':mcm, 'c1':mcc, 'c2':mcc, 'c3':sc}} # was in corner
          3

```

Initially the animal is in one of the four states, with equal probability.

```

_____probHMM.py — (continued)_____
51 # initially we have a uniform distribution over the animal's state

```

```

52 | indist1 = {st:1.0/len(states1) for st in states1}
53 |
54 | hmm1 = HMM(states1, obs1, pobs1, trans1, indist1)

```

### 9.10.1 Exact Filtering for HMMs

A *HMMVEfilter* has a current state distribution which can be updated by observing or by advancing to the next time.

```

_____probHMM.py — (continued)_____
56 | from display import Displayable
57 |
58 | class HMMVEfilter(Displayable):
59 |     def __init__(self, hmm):
60 |         self.hmm = hmm
61 |         self.state_dist = hmm.indist
62 |
63 |     def filter(self, obsseq):
64 |         """updates and returns the state distribution following the
65 |         sequence of
66 |         observations in obsseq using variable elimination.
67 |
68 |         Note that it first advances time.
69 |         This is what is required if it is called sequentially.
70 |         If that is not what is wanted initially, do an observe first.
71 |         """
72 |         for obs in obsseq:
73 |             self.advance() # advance time
74 |             self.observe(obs) # observe
75 |         return self.state_dist
76 |
77 |     def observe(self, obs):
78 |         """updates state conditioned on observations.
79 |         obs is a list of values for each observation variable"""
80 |         for i in self.hmm.obsvars:
81 |             self.state_dist = {st:self.state_dist[st]*(self.hmm.pobs[i][st]
82 |                 if obs[i] else
83 |                 (1-self.hmm.pobs[i][st]))
84 |                 for st in self.hmm.states}
85 |             norm = sum(self.state_dist.values()) # normalizing constant
86 |             self.state_dist = {st:self.state_dist[st]/norm for st in
87 |                 self.hmm.states}
88 |             self.display(2, "After observing", obs, "state
89 |                 distribution:", self.state_dist)
90 |
91 |     def advance(self):
92 |         """advance to the next time"""
93 |         nextstate = {st:0.0 for st in self.hmm.states} # distribution over
94 |             next states
95 |         for j in self.hmm.states: # j ranges over next states

```

```

91         for i in self.hmm.states: # i ranges over previous states
92             nextstate[j] += self.hmm.trans[i][j]*self.state_dist[i]
93         self.state_dist = nextstate
94         self.display(2,"After advancing state
           distribution:",self.state_dist)

```

The following are some queries for *hmm1*.

```

-----probHMM.py --- (continued)-----
96 hmm1f1 = HMMVEfilter(hmm1)
97 # hmm1f1.filter([{'m1':0, 'm2':1, 'm3':1}, {'m1':1, 'm2':0, 'm3':1}])
98 ## HMMVEfilter.max_display_level = 2 # show more detail in displaying
99 # hmm1f2 = HMMVEfilter(hmm1)
100 # hmm1f2.filter([{'m1':1, 'm2':0, 'm3':0}, {'m1':0, 'm2':1, 'm3':0},
101                 {'m1':1, 'm2':0, 'm3':0},
102                 {'m1':0, 'm2':0, 'm3':0}, {'m1':0, 'm2':0, 'm3':0},
103                 {'m1':0, 'm2':0, 'm3':0},
104                 {'m1':0, 'm2':0, 'm3':1}, {'m1':0, 'm2':0, 'm3':1},
105                 {'m1':0, 'm2':0, 'm3':1}])
106 # hmm1f3 = HMMVEfilter(hmm1)
107 # hmm1f3.filter([{'m1':1, 'm2':0, 'm3':0}, {'m1':0, 'm2':0, 'm3':0},
108                 {'m1':1, 'm2':0, 'm3':0}, {'m1':1, 'm2':0, 'm3':1}])
109 # How do the following differ in the resulting state distribution?
110 # Note they start the same, but have different initial observations.
111 ## HMMVEfilter.max_display_level = 1 # show less detail in displaying
112 # for i in range(100): hmm1f1.advance()
113 # hmm1f1.state_dist
114 # for i in range(100): hmm1f3.advance()
115 # hmm1f3.state_dist

```

**Exercise 9.6** The representation assumes that there are a list of Boolean observations. Extend the representation so that the each observation variable can have multiple discrete values. You need to choose a representation for the model, and change the algorithm.

### 9.10.2 Localization

The localization example in the book is a controlled HMM, where there is a given action at each time and the transition depends on the action.

```

-----probLocalization.py --- Controlled HMM and Localization example-----
11 from probHMM import HMMVEfilter, HMM
12 from display import Displayable
13 import matplotlib.pyplot as plt
14 from matplotlib.widgets import Button, CheckButtons
15
16 class HMM_Controlled(HMM):
17     """A controlled HMM, where the transition probability depends on the
           action.

```

```

18     Instead of the transition probability, it has a function act2trans
19     from action to transition probability.
20     Any algorithms need to select the transition probability according
21     to the action.
22     """
23     def __init__(self, states, obsvars, pobs, act2trans, indist):
24         self.act2trans = act2trans
25         HMM.__init__(self, states, obsvars, pobs, None, indist)
26
27     local_states = list(range(16))
28     door_positions = {2,4,7,11}
29     def prob_door(loc): return 0.8 if loc in door_positions else 0.1
30     local_obs = {'door':[prob_door(i) for i in range(16)]}
31     act2trans = {'right': [[0.1 if next == current
32                           else 0.8 if next == (current+1)%16
33                           else 0.074 if next == (current+2)%16
34                           else 0.002 for next in range(16)]
35                      for current in range(16)],
36                  'left': [[0.1 if next == current
37                           else 0.8 if next == (current-1)%16
38                           else 0.074 if next == (current-2)%16
39                           else 0.002 for next in range(16)]
40                          for current in range(16)]}
41     hmm_16pos = HMM_Controlled(local_states, {'door'}, local_obs,
42                               act2trans, [1/16 for i in range(16)])

```

To change the VE localization code to allow for controlled HMMs, notice that the action selects which transition probability to us.

```

_____probLocalization.py — (continued)_____
43 class HMM_Local(HMMVEfilter):
44     """VE filter for controlled HMMs
45     """
46     def __init__(self, hmm):
47         HMMVEfilter.__init__(self, hmm)
48
49     def go(self, action):
50         self.hmm.trans = self.hmm.act2trans[action]
51         self.advance()
52
53     loc_filt = HMM_Local(hmm_16pos)
54     # loc_filt.observe({'door':True}); loc_filt.go("right");
55     # loc_filt.observe({'door':False}); loc_filt.go("right");
56     # loc_filt.observe({'door':True})
57     # loc_filt.state_dist

```

The following lets us interactively move the agent and provide observations. It shows the distribution over locations.

```

_____probLocalization.py — (continued)_____
57 class Show_Localization(Displayable):

```

```

58     def __init__(self,hmm, fontsize=10):
59         self.hmm = hmm
60         self.fontsize = fontsize
61         self.loc_filt = HMM_Local(hmm)
62         fig,(self.ax) = plt.subplots()
63         plt.subplots_adjust(bottom=0.2)
64         ## Set up buttons:
65         left_butt = Button(plt.axes([0.05,0.02,0.1,0.05]), "left")
66         left_butt.label.set_fontsize(self.fontsize)
67         left_butt.on_clicked(self.left)
68         right_butt = Button(plt.axes([0.25,0.02,0.1,0.05]), "right")
69         right_butt.label.set_fontsize(self.fontsize)
70         right_butt.on_clicked(self.right)
71         door_butt = Button(plt.axes([0.45,0.02,0.1,0.05]), "door")
72         door_butt.label.set_fontsize(self.fontsize)
73         door_butt.on_clicked(self.door)
74         nodoor_butt = Button(plt.axes([0.65,0.02,0.1,0.05]), "no door")
75         nodoor_butt.label.set_fontsize(self.fontsize)
76         nodoor_butt.on_clicked(self.nodoor)
77         reset_butt = Button(plt.axes([0.85,0.02,0.1,0.05]), "reset")
78         reset_butt.label.set_fontsize(self.fontsize)
79         reset_butt.on_clicked(self.reset)
80         ## draw the distribution
81         plt.subplot(1, 1, 1)
82         self.draw_dist()
83         plt.show()
84
85     def draw_dist(self):
86         self.ax.clear()
87         plt.ylim(0,1)
88         plt.ylabel("Probability", fontsize=self.fontsize)
89         plt.xlabel("Location", fontsize=self.fontsize)
90         plt.title("Location Probability Distribution",
91                 fontsize=self.fontsize)
92         plt.xticks(self.hmm.states,fontsize=self.fontsize)
93         plt.yticks(fontsize=self.fontsize)
94         vals = [self.loc_filt.state_dist[i] for i in self.hmm.states]
95         self.bars = self.ax.bar(self.hmm.states, vals, color='black')
96         self.ax.bar_label(self.bars,["{v:.2f}".format(v=v) for v in vals],
97                             padding = 1, fontsize=self.fontsize)
98         plt.draw()
99
100    def left(self,event):
101        self.loc_filt.go("left")
102        self.draw_dist()
103
104    def right(self,event):
105        self.loc_filt.go("right")
106        self.draw_dist()
107
108    def door(self,event):
109        self.loc_filt.observe({'door':True})

```

```

106     self.draw_dist()
107     def nodoor(self, event):
108         self.loc_filt.observe({'door': False})
109         self.draw_dist()
110     def reset(self, event):
111         self.loc_filt.state_dist = {i: 1/16 for i in range(16)}
112         self.draw_dist()
113
114 # sl = Show_Localization(hmm_16pos)
115 # sl = Show_Localization(hmm_16pos, fontsize=15) # for demos - enlarge
        window

```

### 9.10.3 Particle Filtering for HMMs

In this implementation a particle is just a state. If you want to do some form of smoothing, a particle should probably be a history of states. This maintains, *particles*, an array of states, *weights* an array of (non-negative) real numbers, such that *weights*[*i*] is the weight of *particles*[*i*].

```

_____probHMM.py — (continued)_____
114 from display import Displayable
115 from probStochSim import resample
116
117 class HMMparticleFilter(Displayable):
118     def __init__(self, hmm, number_particles=1000):
119         self.hmm = hmm
120         self.particles = [sample_one(hmm.indist)
121                          for i in range(number_particles)]
122         self.weights = [1 for i in range(number_particles)]
123
124     def filter(self, obsseq):
125         """returns the state distribution following the sequence of
126         observations in obsseq using particle filtering.
127
128         Note that it first advances time.
129         This is what is required if it is called after previous filtering.
130         If that is not what is wanted initially, do an observe first.
131         """
132         for obs in obsseq:
133             self.advance() # advance time
134             self.observe(obs) # observe
135             self.resample_particles()
136             self.display(2, "After observing", str(obs),
137                          "state distribution:",
138                          self.histogram(self.particles))
139         self.display(1, "Final state distribution:",
140                     self.histogram(self.particles))
141         return self.histogram(self.particles)

```

```

141     def advance(self):
142         """advance to the next time.
143         This assumes that all of the weights are 1."""
144         self.particles = [sample_one(self.hmm.trans[st])
145                             for st in self.particles]
146
147     def observe(self, obs):
148         """reweighs the particles to incorporate observations obs"""
149         for i in range(len(self.particles)):
150             for obv in obs:
151                 if obs[obv]:
152                     self.weights[i] *= self.hmm.pobs[obv][self.particles[i]]
153                 else:
154                     self.weights[i] *=
155                         1-self.hmm.pobs[obv][self.particles[i]]
156
157     def histogram(self, particles):
158         """returns list of the probability of each state as represented by
159         the particles"""
160         tot=0
161         hist = {st: 0.0 for st in self.hmm.states}
162         for (st,wt) in zip(self.particles,self.weights):
163             hist[st]+=wt
164             tot += wt
165         return {st:hist[st]/tot for st in hist}
166
167     def resample_particles(self):
168         """resamples to give a new set of particles."""
169         self.particles = resample(self.particles, self.weights,
170                                 len(self.particles))
171         self.weights = [1] * len(self.particles)

```

The following are some queries for *hmm1*.

```

_____probHMM.py — (continued)_____
171 hmm1pf1 = HMMparticleFilter(hmm1)
172 # HMMparticleFilter.max_display_level = 2 # show each step
173 # hmm1pf1.filter([{'m1':0, 'm2':1, 'm3':1}, {'m1':1, 'm2':0, 'm3':1}])
174 # hmm1pf2 = HMMparticleFilter(hmm1)
175 # hmm1pf2.filter([{'m1':1, 'm2':0, 'm3':0}, {'m1':0, 'm2':1, 'm3':0},
176                 {'m1':1, 'm2':0, 'm3':0},
177                 {'m1':0, 'm2':0, 'm3':0}, {'m1':0, 'm2':0, 'm3':0},
178                 {'m1':0, 'm2':0, 'm3':0},
179                 {'m1':0, 'm2':0, 'm3':1},
180                 {'m1':0, 'm2':0, 'm3':1},
181                 {'m1':0, 'm2':0, 'm3':1}])
182 # hmm1pf3 = HMMparticleFilter(hmm1)
183 # hmm1pf3.filter([{'m1':1, 'm2':0, 'm3':0}, {'m1':0, 'm2':0, 'm3':0},
184                 {'m1':1, 'm2':0, 'm3':0}, {'m1':1, 'm2':0, 'm3':1}])

```

**Exercise 9.7** A form of importance sampling can be obtained by not resampling.

Is it better or worse than particle filtering? Hint: you need to think about how they can be compared. Is the comparison different if there are more states than particles?

**Exercise 9.8** Extend the particle filtering code to continuous variables and observations. In particular, suppose the state transition is a linear function with Gaussian noise of the previous state, and the observations are linear functions with Gaussian noise of the state. You may need to research how to sample from a Gaussian distribution.

### 9.10.4 Generating Examples

The following code is useful for generating examples.

```

182 def simulate(hmm,horizon):
183     """returns a pair of (state sequence, observation sequence) of length
184         horizon.
185     for each time t, the agent is in state_sequence[t] and
186     observes observation_sequence[t]
187     """
188     state = sample_one(hmm.indist)
189     obsseq=[]
190     stateseq=[]
191     for time in range(horizon):
192         stateseq.append(state)
193         newobs =
194             {obs:sample_one({0:1-hmm.pobs[obs][state],1:hmm.pobs[obs][state]})
195             for obs in hmm.obsvars}
196         obsseq.append(newobs)
197         state = sample_one(hmm.trans[state])
198     return stateseq,obsseq
199
200 def simobs(hmm,stateseq):
201     """returns observation sequence for the state sequence"""
202     obsseq=[]
203     for state in stateseq:
204         newobs =
205             {obs:sample_one({0:1-hmm.pobs[obs][state],1:hmm.pobs[obs][state]})
206             for obs in hmm.obsvars}
207         obsseq.append(newobs)
208     return obsseq
209
210 def create_eg(hmm,n):
211     """Create an annotated example for horizon n"""
212     seq,obs = simulate(hmm,n)
213     print("True state sequence:",seq)
214     print("Sequence of observations:\n",obs)
215     hmmfilter = HMMVEfilter(hmm)
216     dist = hmmfilter.filter(obs)

```

```
214 | print("Resulting distribution over states:\n",dist)
```

## 9.11 Dynamic Belief Networks

A **dynamic belief network (DBN)** is a belief network that extends in time.

There are a number of ways that reasoning can be carried out in a DBN, including:

- Rolling out the DBN for some time period, and using standard belief network inference. The latest time that needs to be in the rolled out network is the time of the latest observation or the time of a query (whichever is later). This allows us to observe any variables at any time and query any variables at any time. This is covered in Section 9.11.2.
- An unrolled belief network may be very large, and we might only be interested in asking about “now”. In this case we can just representing the variables “now”. In this approach we can observe and query the current variables. We can them move to the next time. This does not allow for arbitrary historical queries (about the past or the future), but can be much simpler. This is covered in Section 9.11.3.

### 9.11.1 Representing Dynamic Belief Networks

To specify a DBN, think about the distribution *now*. *Now* will be represented as time 1. Each variable will have a corresponding previous variable; these will be created together.

A dynamic belief network consists of:

- A set of features. A variable is a feature-time pair.
- An initial distribution over the features “now” (time 1). This is a belief network with all variables being time 1 variables.
- A specification of the dynamics. We define the how the variables *now* (time 1) depend on variables *now* and the previous time (time 0), in such a way that the graph is acyclic.

```

_____probDBN.py — Dynamic belief networks_____
11 from variable import Variable
12 from probGraphicalModels import GraphicalModel, BeliefNetwork
13 from probFactors import Prob, Factor, CPD
14 from probVE import VE
15 from display import Displayable
16
17 class DBNvariable(Variable):
18     """A random variable that incorporates the stage (time)

```

```

19
20 A variable can have both a name and an index. The index defaults to 1.
21 """
22 def __init__(self,name,domain=[False,True],index=1):
23     Variable.__init__(self,f"{name}_{index}",domain)
24     self.basename = name
25     self.domain = domain
26     self.index = index
27     self.previous = None
28
29 def __lt__(self,other):
30     if self.name != other.name:
31         return self.name<other.name
32     else:
33         return self.index<other.index
34
35 def __gt__(self,other):
36     return other<self
37
38 def variable_pair(name,domain=[False,True]):
39     """returns a variable and its predecessor. This is used to define
40         2-stage DBNs
41
42     If the name is X, it returns the pair of variables X_prev,X_now"""
43     var_now = DBNvariable(name,domain,index='now')
44     var_prev = DBNvariable(name,domain,index='prev')
45     var_now.previous = var_prev
46     return var_prev, var_now

```

A *FactorRename* is a factor that is the result renaming the variables in the factor. It takes a factor, *fac*, and a  $\{new : old\}$  dictionary, where *new* is the name of a variable in the resulting factor and *old* is the corresponding name in *fac*. This assumes that the all variables are renamed.

probDBN.py — (continued)

```

47 class FactorRename(Factor):
48     def __init__(self,fac,renaming):
49         """A renamed factor.
50         fac is a factor
51         renaming is a dictionary of the form {new:old} where old and new
52         var variables,
53         where the variables in fac appear exactly once in the renaming
54         """
55         Factor.__init__(self,[n for (n,o) in renaming.items() if o in
56             fac.variables])
57         self.orig_fac = fac
58         self.renaming = renaming
59
60     def get_value(self,assignment):
61         return self.orig_fac.get_value({self.renaming[var]:val
62             for (var,val) in assignment.items()

```

```
61 |                                     if var in self.variables})
```

The following class renames the variables of a conditional probability distribution. It is used for template models (e.g., dynamic decision networks or relational models)

```

_____probDBN.py — (continued) _____
63 | class CPDrename(FactorRename, CPD):
64 |     def __init__(self, cpd, renaming):
65 |         renaming_inverse = {old:new for (new,old) in renaming.items()}
66 |         CPD.__init__(self,renaming_inverse[cpd.child],[renaming_inverse[p]
        |             for p in cpd.parents])
67 |         self.orig_fac = cpd
68 |         self.renaming = renaming

```

```

_____probDBN.py — (continued) _____
70 | class DBN(Displayable):
71 |     """The class of stationary Dynamic Belief networks.
72 |     * name is the DBN name
73 |     * vars_now is a list of current variables (each must have
74 |     previous variable).
75 |     * transition_factors is a list of factors for P(X|parents) where X
76 |     is a current variable and parents is a list of current or previous
        |     variables.
77 |     * init_factors is a list of factors for P(X|parents) where X is a
78 |     current variable and parents can only include current variables
79 |     The graph of transition factors + init factors must be acyclic.
80 |
81 |     """
82 |     def __init__(self, title, vars_now, transition_factors=None,
        |         init_factors=None):
83 |         self.title = title
84 |         self.vars_now = vars_now
85 |         self.vars_prev = [v.previous for v in vars_now]
86 |         self.transition_factors = transition_factors
87 |         self.init_factors = init_factors
88 |         self.var_index = {} # var_index[v] is the index of variable v
89 |         for i,v in enumerate(vars_now):
90 |             self.var_index[v]=i

```

Here is a 3 variable DBN:

```

_____probDBN.py — (continued) _____
92 | A0,A1 = variable_pair("A", domain=[False,True])
93 | B0,B1 = variable_pair("B", domain=[False,True])
94 | C0,C1 = variable_pair("C", domain=[False,True])
95 |
96 | # dynamics
97 | pc = Prob(C1,[B1,C0],[[[[0.03,0.97],[0.38,0.62]],[[0.23,0.77],[0.78,0.22]]]])
98 | pb = Prob(B1,[A0,A1],[[[[0.5,0.5],[0.77,0.23]],[[0.4,0.6],[0.83,0.17]]]])
99 | pa = Prob(A1,[A0,B0],[[[[0.1,0.9],[0.65,0.35]],[[0.3,0.7],[0.8,0.2]]]])

```

```

100
101 # initial distribution
102 pa0 = Prob(A1,[],[0.9,0.1])
103 pb0 = Prob(B1,[A1],[[0.3,0.7],[0.8,0.2]])
104 pc0 = Prob(C1,[],[0.2,0.8])
105
106 dbn1 = DBN("Simple DBN",[A1,B1,C1],[pa,pb,pc],[pa0,pb0,pc0])

```

Here is the animal example

```

-----probDBN.py --- (continued)-----
108 from probHMM import closeMic, farMic, midMic, sm, mmc, sc, mcm, mcc
109
110 Pos_0,Pos_1 = variable_pair("Position",domain=[0,1,2,3])
111 Mic1_0,Mic1_1 = variable_pair("Mic1")
112 Mic2_0,Mic2_1 = variable_pair("Mic2")
113 Mic3_0,Mic3_1 = variable_pair("Mic3")
114
115 # conditional probabilities - see hmm for the values of sm,mmc, etc
116 ppos = Prob(Pos_1, [Pos_0],
117             [[sm, mmc, mmc, mmc], #was in middle
118              [mcm, sc, mcc, mcc], #was in corner 1
119              [mcm, mcc, sc, mcc], #was in corner 2
120              [mcm, mcc, mcc, sc]]) #was in corner 3
121 pm1 = Prob(Mic1_1, [Pos_1], [[1-midMic, midMic], [1-closeMic, closeMic],
122                             [1-farMic, farMic], [1-farMic, farMic]])
123 pm2 = Prob(Mic2_1, [Pos_1], [[1-midMic, midMic], [1-farMic, farMic],
124                             [1-closeMic, closeMic], [1-farMic, farMic]])
125 pm3 = Prob(Mic3_1, [Pos_1], [[1-midMic, midMic], [1-farMic, farMic],
126                             [1-farMic, farMic], [1-closeMic, closeMic]])
127 ipos = Prob(Pos_1,[], [0.25, 0.25, 0.25, 0.25])
128 dbn_an =DBN("Animal DBN",[Pos_1,Mic1_1,Mic2_1,Mic3_1],
129            [ppos, pm1, pm2, pm3],
130            [ipos, pm1, pm2, pm3])

```

### 9.11.2 Unrolling DBNs

```

-----probDBN.py --- (continued)-----
132 class BNfromDBN(BeliefNetwork):
133     """Belief Network unrolled from a dynamic belief network
134     """
135
136     def __init__(self,dbn,horizon):
137         """dbn is the dynamic belief network being unrolled
138         horizon>0 is the number of steps (so there will be horizon+1
139         variables for each DBN variable.
140         """
141         self.name2var = {var.basename:
142                         [DBNvariable(var.basename,var.domain,index) for index in
143                          range(horizon+1)]

```

```

141         for var in dbn.vars_now}
142     self.display(1, f"name2var={self.name2var}")
143     variables = {v for vs in self.name2var.values() for v in vs}
144     self.display(1, f"variables={variables}")
145     bnfactors = {CPDrename(fac, {self.name2var[var.basename][0]:var
146                       for var in fac.variables})
147                for fac in dbn.init_factors}
148     bnfactors |= {CPDrename(fac, {self.name2var[var.basename][i]:var
149                       for var in fac.variables if
150                          var.index=='prev'})
151                 | {self.name2var[var.basename][i+1]:var
152                   for var in fac.variables if
153                      var.index=='now'}}
152     for fac in dbn.transition_factors
153         for i in range(horizon)}
154     self.display(1, f"bnfactors={bnfactors}")
155     BeliefNetwork.__init__(self, dbn.title, variables, bnfactors)

```

Here are two examples. Note that we need to use `bn.name2var['B'][2]` to get the variable B2 (B at time 2).

```

_____probDBN.py — (continued)_____
157 # Try
158 #from probRC import ProbRC
159 #bn = BNfromDBN(dbn1,2) # construct belief network
160 #drc = ProbRC(bn)      # initialize recursive conditioning
161 #B2 = bn.name2var['B'][2]
162 #drc.query(B2) #P(B2)
163 #drc.query(bn.name2var['B'][1], {bn.name2var['B'][0]:True, bn.name2var['C'][1]:False})
    #P(B1|B0,C1)

```

### 9.11.3 DBN Filtering

If we only wanted to ask questions about the current state, we can save space by forgetting the history variables.

```

_____probDBN.py — (continued)_____
164 class DBNVEfilter(VE):
165     def __init__(self, dbn):
166         self.dbn = dbn
167         self.current_factors = dbn.init_factors
168         self.current_obs = {}
169
170     def observe(self, obs):
171         """updates the current observations with obs.
172         obs is a variable:value dictionary where variable is a current
173         variable.
174         """
175         assert all(self.current_obs[var]==obs[var] for var in obs
176                  if var in self.current_obs), "inconsistent current
            observations"

```

```

177         self.current_obs.update(obs) # note 'update' is a dict method
178
179     def query(self,var):
180         """returns the posterior probability of current variable var"""
181         return
182             VE(GraphicalModel(self.dbn.title,self.dbn.vars_now,self.current_factors)).query(var,self.c
183
184     def advance(self):
185         """advance to the next time"""
186         prev_factors = [self.make_previous(fac) for fac in
187             self.current_factors]
188         prev_obs = {var.previous:val for var,val in
189             self.current_obs.items()}
190         two_stage_factors = prev_factors + self.dbn.transition_factors
191         self.current_factors =
192             self.elim_vars(two_stage_factors,self.dbn.vars_prev,prev_obs)
193         self.current_obs = {}
194
195     def make_previous(self,fac):
196         """Creates new factor from fac where the current variables in fac
197         are renamed to previous variables.
198         """
199         return FactorRename(fac, {var.previous:var for var in
200             fac.variables})
201
202     def elim_vars(self,factors, vars, obs):
203         for var in vars:
204             if var in obs:
205                 factors = [self.project_observations(fac,obs) for fac in
206                     factors]
207             else:
208                 factors = self.eliminate_var(factors, var)
209         return factors

```

Example queries:

```

-----probDBN.py --- (continued)-----
205 #df = DBNVEfilter(dbn1)
206 #df.observe({B1:True}); df.advance(); df.observe({C1:False})
207 #df.query(B1) #P(B1|B0,C1)
208 #df.advance(); df.query(B1)
209 #dfa = DBNVEfilter(dbn_an)
210 # dfa.observe({Mic1_1:0, Mic2_1:1, Mic3_1:1})
211 # dfa.advance()
212 # dfa.observe({Mic1_1:1, Mic2_1:0, Mic3_1:1})
213 # dfa.query(Pos_1)

```

## Learning with Uncertainty

### 10.1 Bayesian Learning

The section contains two implementations of the (discretized) beta distribution. The first represents Bayesian learning as a belief network. The second is an interactive tool to understand the beta distribution.

The following uses a belief network representation from the previous chapter to learn (discretized) probabilities. Figure 10.1 shows the output after observing *heads, heads, tails*. Notice the prediction of future tosses.

```
learnBayesian.py — Bayesian Learning
11 from variable import Variable
12 from probFactors import Prob
13 from probGraphicalModels import BeliefNetwork
14 from probRC import ProbRC
15
16 ##### Coin Toss ###
17 # multiple coin tosses:
18 toss = ['tails', 'heads']
19 tosses = [ Variable(f"Toss#{i}", toss,
20                 (0.8, 0.9-i/10) if i<10 else (0.4,0.2))
21           for i in range(11)]
22
23 def coinTossBN(num_bins = 10):
24     prob_bins = [x/num_bins for x in range(num_bins+1)]
25     PH = Variable("P_heads", prob_bins, (0.1,0.9))
26     p_PH = Prob(PH,[],{x:0.5/num_bins if x in [0,1] else 1/num_bins for x
27                 in prob_bins})
28     p_tosses = [ Prob(tosses[i],[PH], {x: {'tails':1-x, 'heads':x} for x in
29                 prob_bins})
30                 for i in range(11)]
```

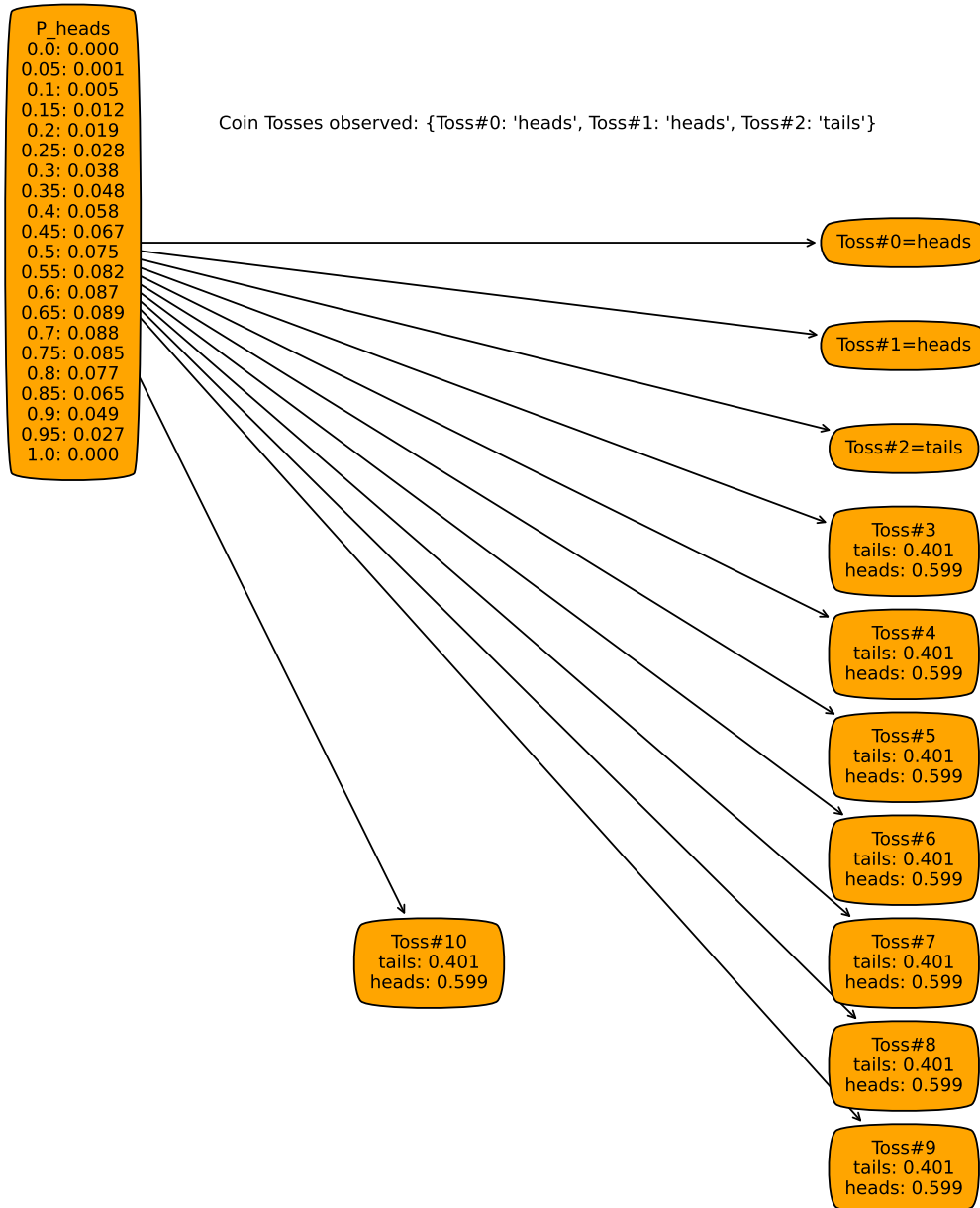

Figure 10.1: coinTossBN after observing heads, heads, tails

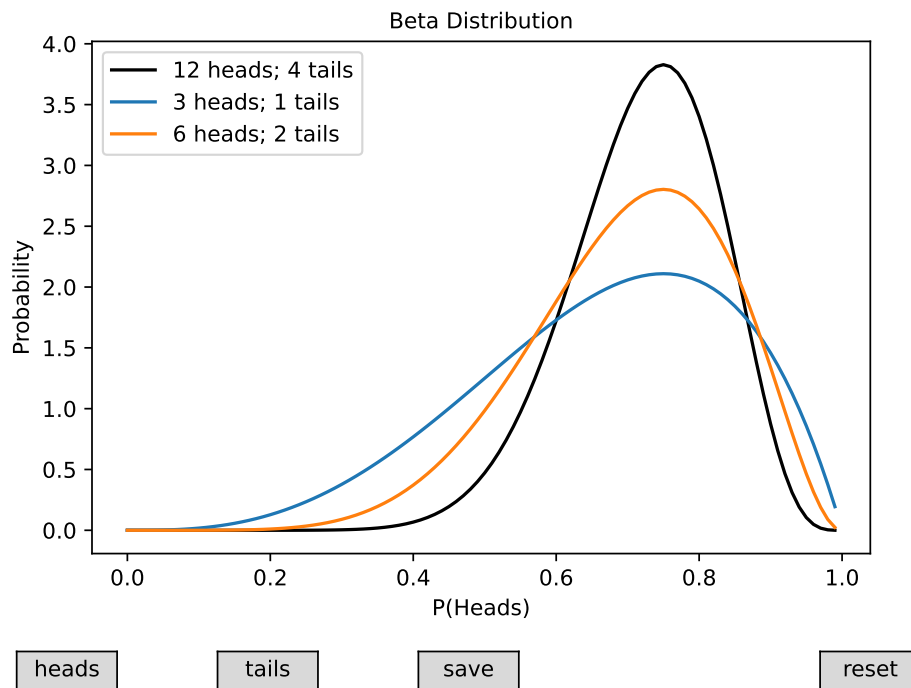

Figure 10.2: Beta distribution after some observations

```

29     return BeliefNetwork("Coin Tosses",
30                           [PH]+tosses,
31                           [p_PH]+p_tosses)
32
33
34 #
35 # coinRC = ProbRC(coinTossBN(20))
36 # coinRC.query(tosses[10],{tosses[0]: 'heads'})
37 # coinRC.show_post({})
38 # coinRC.show_post({tosses[0]: 'heads'})
39 # coinRC.show_post({tosses[0]: 'heads', tosses[1]: 'heads'})
40 # coinRC.show_post({tosses[0]: 'heads', tosses[1]: 'heads', tosses[2]: 'tails'})

```

Figure 10.2 shows a plot of the Beta distribution (the  $P_{head}$  variable in the previous belief network) given some sets of observations.

This is a plot that is produced by the following interactive tool.

```

learnBayesian.py — (continued)
42 from display import Displayable
43 import matplotlib.pyplot as plt
44 from matplotlib.widgets import Button, CheckButtons
45
46 class Show_Beta(Displayable):

```

```

47 def __init__(self,num=100, fontsize=10):
48     self.num = num
49     self.dist = [1 for i in range(num)]
50     self.vals = [i/num for i in range(num)]
51     self.fontsize = fontsize
52     self.saves = []
53     self.num_heads = 0
54     self.num_tails = 0
55     plt.ioff()
56     fig,(self.ax) = plt.subplots()
57     plt.subplots_adjust(bottom=0.2)
58     ## Set up buttons:
59     heads_butt = Button(plt.axes([0.05,0.02,0.1,0.05]), "heads")
60     heads_butt.label.set_fontsize(self.fontsize)
61     heads_butt.on_clicked(self.heads)
62     tails_butt = Button(plt.axes([0.25,0.02,0.1,0.05]), "tails")
63     tails_butt.label.set_fontsize(self.fontsize)
64     tails_butt.on_clicked(self.tails)
65     save_butt = Button(plt.axes([0.45,0.02,0.1,0.05]), "save")
66     save_butt.label.set_fontsize(self.fontsize)
67     save_butt.on_clicked(self.save)
68     reset_butt = Button(plt.axes([0.85,0.02,0.1,0.05]), "reset")
69     reset_butt.label.set_fontsize(self.fontsize)
70     reset_butt.on_clicked(self.reset)
71     ## draw the distribution
72     plt.subplot(1, 1, 1)
73     self.draw_dist()
74     plt.show()
75
76 def draw_dist(self):
77     sv = self.num/sum(self.dist)
78     self.dist = [v*sv for v in self.dist]
79     #print(self.dist)
80     self.ax.clear()
81     plt.ylabel("Probability", fontsize=self.fontsize)
82     plt.xlabel("P(Heads)", fontsize=self.fontsize)
83     plt.title("Beta Distribution", fontsize=self.fontsize)
84     plt.xticks(fontsize=self.fontsize)
85     plt.yticks(fontsize=self.fontsize)
86     self.ax.plot(self.vals, self.dist, color='black', label =
87         f"{self.num_heads} heads; {self.num_tails} tails")
88     for (nh,nt,d) in self.saves:
89         self.ax.plot(self.vals, d, label = f"{nh} heads; {nt} tails")
90     self.ax.legend()
91     plt.draw()
92
93 def heads(self,event):
94     self.num_heads += 1
95     self.dist = [self.dist[i]*self.vals[i] for i in range(self.num)]
96     self.draw_dist()

```

```

96     def tails(self, event):
97         self.num_tails += 1
98         self.dist = [self.dist[i]*(1-self.vals[i]) for i in range(self.num)]
99         self.draw_dist()
100    def save(self, event):
101        self.saves.append((self.num_heads, self.num_tails, self.dist))
102        self.draw_dist()
103    def reset(self, event):
104        self.num_tails = 0
105        self.num_heads = 0
106        self.dist = [1/self.num for i in range(self.num)]
107        self.draw_dist()
108
109 # s1 = Show_Beta(100)
110 # s1 = Show_Beta(100, fontsize=15) # for demos - enlarge window

```

## 10.2 K-means

The k-means learner maintains two lists that suffice as sufficient statistics to classify examples, and to learn the classification:

- *class\_counts* is a list such that *class\_counts*[*c*] is the number of examples in the training set with *class* = *c*.
- *feature\_sum* is a list such that *feature\_sum*[*i*][*c*] is sum of the values for the *i*'th feature *i* for members of class *c*. The average value of the *i*th feature in class *i* is

$$\frac{\text{feature\_sum}[i][c]}{\text{class\_counts}[c]}$$

The class is initialized by randomly assigning examples to classes, and updating the statistics for *class\_counts* and *feature\_sum*.

```

learnKMeans.py — k-means learning
11 from learnProblem import Data_set, Learner, Data_from_file
12 import random
13 import matplotlib.pyplot as plt
14
15 class K_means_learner(Learner):
16     def __init__(self, dataset, num_classes):
17         self.dataset = dataset
18         self.num_classes = num_classes
19         self.random_initialize()
20
21     def random_initialize(self):
22         # class_counts[c] is the number of examples with class=c
23         self.class_counts = [0]*self.num_classes

```

```

24 |         # feature_sum[i][c] is the sum of the values of feature i for class
      |         c
25 |         self.feature_sum = [[0]*self.num_classes
      |                             for feat in self.dataset.input_features]
26 |     for eg in self.dataset.train:
27 |         cl = random.randrange(self.num_classes) # assign eg to random
      |         class
29 |         self.class_counts[cl] += 1
30 |         for (ind,feat) in enumerate(self.dataset.input_features):
31 |             self.feature_sum[ind][cl] += feat(eg)
32 |     self.num_iterations = 0
33 |     self.display(1,"Initial class counts: ",self.class_counts)

```

The distance from (the mean of) a class to an example is the sum, over all features, of the sum-of-squares differences of the class mean and the example value.

```

-----learnKMeans.py --- (continued) -----
35 | def distance(self,cl,eg):
36 |     """distance of the eg from the mean of the class"""
37 |     return sum( (self.class_prediction(ind,cl)-feat(eg))**2
38 |                for (ind,feat) in
      |                enumerate(self.dataset.input_features))
39 |
40 | def class_prediction(self,feat_ind,cl):
41 |     """prediction of the class cl on the feature with index feat_ind"""
42 |     if self.class_counts[cl] == 0:
43 |         return 0 # there are no examples so we can choose any value
44 |     else:
45 |         return self.feature_sum[feat_ind][cl]/self.class_counts[cl]
46 |
47 | def class_of_eg(self,eg):
48 |     """class to which eg is assigned"""
49 |     return (min((self.distance(cl,eg),cl)
50 |                for cl in range(self.num_classes)))[1]
51 |     # second element of tuple, which is a class with minimum
      |     distance

```

One step of k-means updates the *class\_counts* and *feature\_sum*. It uses the old values to determine the classes, and so the new values for *class\_counts* and *feature\_sum*. At the end it determines whether the values of these have changes, and then replaces the old ones with the new ones. It returns an indicator of whether the values are stable (have not changed).

```

-----learnKMeans.py --- (continued) -----
53 | def k_means_step(self):
54 |     """Updates the model with one step of k-means.
55 |     Returns whether the assignment is stable.
56 |     """
57 |     new_class_counts = [0]*self.num_classes

```

```

58     # feature_sum[i][c] is the sum of the values of feature i for class
59     # c
60     new_feature_sum = [[0]*self.num_classes
61                       for feat in self.dataset.input_features]
62     for eg in self.dataset.train:
63         cl = self.class_of_eg(eg)
64         new_class_counts[cl] += 1
65         for (ind,feat) in enumerate(self.dataset.input_features):
66             new_feature_sum[ind][cl] += feat(eg)
67     stable = (new_class_counts == self.class_counts) and
68             (self.feature_sum == new_feature_sum)
69     self.class_counts = new_class_counts
70     self.feature_sum = new_feature_sum
71     self.num_iterations += 1
72     return stable
73
74 def learn(self,n=100):
75     """do n steps of k-means, or until convergence"""
76     i=0
77     stable = False
78     while i<n and not stable:
79         stable = self.k_means_step()
80         i += 1
81         self.display(1,"Iteration",self.num_iterations,
82                     "class counts: ",self.class_counts,"
83                     Stable=",stable)
84     return stable
85
86 def show_classes(self):
87     """sorts the data by the class and prints in order.
88     For visualizing small data sets
89     """
90     class_examples = [[] for i in range(self.num_classes)]
91     for eg in self.dataset.train:
92         class_examples[self.class_of_eg(eg)].append(eg)
93     print("Class", "Example", sep='\t')
94     for cl in range(self.num_classes):
95         for eg in class_examples[cl]:
96             print(cl,*eg,sep='\t')
97
98 def plot_error(self, maxstep=20):
99     """Plots the sum-of-squares error as a function of the number of
100     steps"""
101     plt.ion()
102     plt.xlabel("step")
103     plt.ylabel("Ave sum-of-squares error")
104     train_errors = []
105     if self.dataset.test:
106         test_errors = []

```

```

104     for i in range(maxstep):
105         self.learn(1)
106         train_errors.append( sum(self.distance(self.class_of_eg(eg),eg)
107                               for eg in self.dataset.train)
108                             /len(self.dataset.train))
109         if self.dataset.test:
110             test_errors.append(
111                 sum(self.distance(self.class_of_eg(eg),eg)
112                     for eg in self.dataset.test)
113                 /len(self.dataset.test))
114     plt.plot(range(1,maxstep+1),train_errors,
115             label=str(self.num_classes)+" classes. Training set")
116     if self.dataset.test:
117         plt.plot(range(1,maxstep+1),test_errors,
118                 label=str(self.num_classes)+" classes. Test set")
119     plt.legend()
120     plt.draw()
121 %data = Data_from_file('data/emdata1.csv', num_train=10,
122                       target_index=2000) % trivial example
123 data = Data_from_file('data/emdata2.csv', num_train=10, target_index=2000)
124 %data = Data_from_file('data/emdata0.csv', num_train=14,
125                       target_index=2000) % example from textbook
126 kml = K_means_learner(data,2)
127 num_iter=4
128 print("Class assignment after",num_iter,"iterations:")
129 kml.learn(num_iter); kml.show_classes()
130
131 # Plot the error
132 # km2=K_means_learner(data,2); km2.plot_error(20) # 2 classes
133 # km3=K_means_learner(data,3); km3.plot_error(20) # 3 classes
134 # km13=K_means_learner(data,13); km13.plot_error(20) # 13 classes
135
136 # data = Data_from_file('data/carbool.csv',
137                       target_index=2000,boolean_features=True)
138 # kml = K_means_learner(data,3)
139 # kml.learn(20); kml.show_classes()
140 # km3=K_means_learner(data,3); km3.plot_error(20) # 3 classes
141 # km3=K_means_learner(data,30); km3.plot_error(20) # 30 classes

```

**Exercise 10.1** Change *boolean\_features = True* flag to allow for numerical features. K-means assumes the features are numerical, so we want to make non-numerical features into numerical features (using characteristic functions) but we probably don't want to change numerical features into Boolean.

**Exercise 10.2** If there are many classes, some of the classes can become empty (e.g., try 100 classes with *carbool.csv*). Implement a way to put some examples into a class, if possible. Two ideas are:

- (a) Initialize the classes with actual examples, so that the classes will not start empty. (Do the classes become empty?)

- (b) In *class\_prediction*, we test whether the code is empty, and make a prediction of 0 for an empty class. It is possible to make a different prediction to “steal” an example (but you should make sure that a class has a consistent value for each feature in a loop).

Make your own suggestions, and compare it with the original, and whichever of these you think may work better.

## 10.3 EM

In the following definition, a class,  $c$ , is a integer in range  $[0, num\_classes)$ .  $i$  is an index of a feature, so  $feat[i]$  is the  $i$ th feature, and a feature is a function from tuples to values.  $val$  is a value of a feature.

A model consists of 2 lists, which form the sufficient statistics:

- *class\_counts* is a list such that  $class\_counts[c]$  is the number of tuples with  $class = c$ , where each tuple is weighted by its probability, i.e.,

$$class\_counts[c] = \sum_{t: class(t)=c} P(t)$$

- *feature\_counts* is a list such that  $feature\_counts[i][val][c]$  is the weighted count of the number of tuples  $t$  with  $feat[i](t) = val$  and  $class(t) = c$ , each tuple is weighted by its probability, i.e.,

$$feature\_counts[i][val][c] = \sum_{t: feat[i](t)=val \text{ and } class(t)=c} P(t)$$

```

learnEM.py — EM Learning
11 from learnProblem import Data_set, Learner, Data_from_file
12 import random
13 import math
14 import matplotlib.pyplot as plt
15
16 class EM_learner(Learner):
17     def __init__(self, dataset, num_classes):
18         self.dataset = dataset
19         self.num_classes = num_classes
20         self.class_counts = None
21         self.feature_counts = None

```

The function *em\_step* goes though the training examples, and updates these counts. The first time it is run, when there is no model, it uses random distributions.

```

learnEM.py — (continued)
23 def em_step(self, orig_class_counts, orig_feature_counts):

```

```

24     """updates the model."""
25     class_counts = [0]*self.num_classes
26     feature_counts = [{val:[0]*self.num_classes
27                       for val in feat.frange}
28                      for feat in self.dataset.input_features]
29     for tple in self.dataset.train:
30         if orig_class_counts: # a model exists
31             tpl_class_dist = self.prob(tple, orig_class_counts,
32                                       orig_feature_counts)
33         else: # initially, with no model, return a random
34             distribution
35             tpl_class_dist = random_dist(self.num_classes)
36         for cl in range(self.num_classes):
37             class_counts[cl] += tpl_class_dist[cl]
38             for (ind,feat) in enumerate(self.dataset.input_features):
39                 feature_counts[ind][feat(tple)][cl] += tpl_class_dist[cl]
39     return class_counts, feature_counts

```

*prob* computes the probability of a class *c* for a tuple *tple*, given the current statistics.

$$\begin{aligned}
 P(c \mid tple) &\propto P(c) * \prod_i P(X_i=tple(i) \mid c) \\
 &= \frac{\text{class\_counts}[c]}{\text{len}(\text{self.dataset})} * \prod_i \frac{\text{feature\_counts}[i][\text{feat}_i(\text{tple})][c]}{\text{class\_counts}[c]} \\
 &\propto \frac{\prod_i \text{feature\_counts}[i][\text{feat}_i(\text{tple})][c]}{\text{class\_counts}[c]^{|\text{feats}|-1}}
 \end{aligned}$$

The last step is because  $\text{len}(\text{self.dataset})$  is a constant (independent of *c*).  $\text{class\_counts}[c]$  can be taken out of the product, but needs to be raised to the power of the number of features, and one of them cancels.

```

learnEM.py — (continued)
40     def prob(self, tple, class_counts, feature_counts):
41         """returns a distribution over the classes for tuple tple in the
42            model defined by the counts
43         """
44         feats = self.dataset.input_features
45         unnorm = [prod(feature_counts[i][feat(tple)][c]
46                       for (i,feat) in enumerate(feats))
47                  /(class_counts[c]**(len(feats)-1))
48                  for c in range(self.num_classes)]
49         thesum = sum(unnorm)
50         return [un/thesum for un in unnorm]

```

*learn* does *n* steps of EM:

```

learnEM.py — (continued)
51     def learn(self,n):
52         """do n steps of em"""

```

```

53     for i in range(n):
54         self.class_counts, self.feature_counts =
55             self.em_step(self.class_counts,
                           self.feature_counts)

```

The following is for visualizing the classes. It prints the dataset ordered by the probability of class  $c$ .

```

learnEM.py — (continued)
57     def show_class(self, c):
58         """sorts the data by the class and prints in order.
59         For visualizing small data sets
60         """
61         sorted_data =
62             sorted((self.prob(tpl, self.class_counts, self.feature_counts)[c],
63                    ind, # preserve ordering for equal
64                       probabilities
65                       tpl)
66                   for (ind, tpl) in enumerate(self.dataset.train))
67         for cc, r, tpl in sorted_data:
68             print(cc, *tpl, sep='\t')

```

The following are for evaluating the classes.

The probability of a tuple can be evaluated by marginalizing over the classes:

$$\begin{aligned}
 P(\text{tuple}) &= \sum_c P(c) * \prod_i P(X_i = \text{tuple}(i) | c) \\
 &= \sum_c \frac{cc[c]}{\text{len}(\text{self.dataset})} * \prod_i \frac{fc[i][\text{feat}_i(\text{tuple})][c]}{cc[c]}
 \end{aligned}$$

where  $cc$  is the class count and  $fc$  is feature count.  $\text{len}(\text{self.dataset})$  can be distributed out of the sum, and  $cc[c]$  can be taken out of the product:

$$= \frac{1}{\text{len}(\text{self.dataset})} \sum_c \frac{1}{cc[c]^{\#\text{feats}-1}} * \prod_i fc[i][\text{feat}_i(\text{tuple})][c]$$

Given the probability of each tuple, we can evaluate the logloss, as the negative of the log probability:

```

learnEM.py — (continued)
68     def logloss(self, tuple):
69         """returns the logloss of the prediction on tuple, which is
70         -log(P(tuple))
71         based on the current class counts and feature counts
72         """
73         feats = self.dataset.input_features
74         res = 0
75         cc = self.class_counts
76         fc = self.feature_counts
77         for c in range(self.num_classes):
78             res += prod(fc[i][feat(tuple)][c]

```

```

78         for (i,feat) in
79             enumerate(feats)/(cc[c]**(len(feats)-1))
80     if res>0:
81         return -math.log2(res/len(self.dataset.train))
82     else:
83         return float("inf") #infinity
84
85 def plot_error(self, maxstep=20):
86     """Plots the logloss error as a function of the number of steps"""
87     plt.ion()
88     plt.xlabel("step")
89     plt.ylabel("Ave Logloss (bits)")
90     train_errors = []
91     if self.dataset.test:
92         test_errors = []
93     for i in range(maxstep):
94         self.learn(1)
95         train_errors.append( sum(self.logloss(tple) for tple in
96                               self.dataset.train)
97                             /len(self.dataset.train))
98         if self.dataset.test:
99             test_errors.append( sum(self.logloss(tple) for tple in
100                                  self.dataset.test)
101                                /len(self.dataset.test))
102     plt.plot(range(1,maxstep+1),train_errors,
103             label=str(self.num_classes)+" classes. Training set")
104     if self.dataset.test:
105         plt.plot(range(1,maxstep+1),test_errors,
106                 label=str(self.num_classes)+" classes. Test set")
107     plt.legend()
108     plt.draw()
109
110 def prod(L):
111     """returns the product of the elements of L"""
112     res = 1
113     for e in L:
114         res *= e
115     return res
116
117 def random_dist(k):
118     """generate k random numbers that sum to 1"""
119     res = [random.random() for i in range(k)]
120     s = sum(res)
121     return [v/s for v in res]
122
123 data = Data_from_file('data/emdata2.csv', num_train=10, target_index=2000)
124 eml = EM_learner(data,2)
125 num_iter=2
126 print("Class assignment after",num_iter,"iterations:")
127 eml.learn(num_iter); eml.show_class(0)

```

```
125 |
126 | # Plot the error
127 | # em2=EM_learner(data,2); em2.plot_error(40) # 2 classes
128 | # em3=EM_learner(data,3); em3.plot_error(40) # 3 classes
129 | # em13=EM_learner(data,13); em13.plot_error(40) # 13 classes
130 |
131 | # data = Data_from_file('data/carbool.csv',
132 |     target_index=2000,boolean_features=False)
133 | # [f.frange for f in data.input_features]
134 | # em1 = EM_learner(data,3)
135 | # em1.learn(20); em1.show_class(0)
136 | # em3=EM_learner(data,3); em3.plot_error(60) # 3 classes
137 | # em3=EM_learner(data,30); em3.plot_error(60) # 30 classes
```

**Exercise 10.3** For the EM data, where there are naturally 2 classes, 3 classes does better on the training set after a while than 2 classes, but worse on the test set. Explain why. Hint: look what the 3 classes are. Use “em3.show\_class(i)” for each of the classes  $i \in [0, 3)$ .

**Exercise 10.4** Write code to plot the logloss as a function of the number of classes (from 1 to say 15) for a fixed number of iterations. (From the experience with the existing code, think about how many iterations is appropriate.)



## Causality

### 11.1 Do Questions

A causal model can answer “do” questions.

The `intervene` function takes a belief network and a variable:value dictionary specifying what to “do”, and returns a belief network resulting from intervening to set each variable in the dictionary to its value specified. It replaces each CPD with an constant CPD.

```
_____probDo.py — Probabilistic inference with the do operator _____
11 from probGraphicalModels import InferenceMethod, BeliefNetwork
12 from probFactors import CPD, ConstantCPD
13
14 def intervene(bn, do={}):
15     assert isinstance(bn, BeliefNetwork), f"Do only applies to belief
16         networks ({bn.title})"
17     if do=={}:
18         return bn
19     else:
20         newfacs = ({f for (ch,f) in bn.var2cpt.items() if ch not in do} |
21             {ConstantCPD(v,c) for (v,c) in do.items()})
22         return BeliefNetwork(f"{bn.title}(do={do})", bn.variables, newfacs)
```

The following adds the `queryDo` method to the `InferenceMethod` class, so it can be used with any inference method. It replaces the graphical model with the modified one, runs the inference algorithm, and resores the initial belief network.

```
_____probDo.py — (continued) _____
23 def queryDo(self, qvar, obs={}, do={}):
24     """Extends query method to also allow for interventions.
25     """
```

```

26     oldBN, self.gm = self.gm, intervene(self.gm, do)
27     result = self.query(qvar, obs)
28     self.gm = oldBN # restore original
29     return result
30
31 # make queryDo available for all inference methods
32 InferenceMethod.queryDo = queryDo

```

Test cases:

```

_____probDo.py — (continued)_____
34 from probRC import ProbRC
35
36 from probExamples import bn_sprinkler, Season, Sprinkler, Rained,
    Grass_wet, Grass_shiny, Shoes_wet
37 bn_sprinklerv = ProbRC(bn_sprinkler)
38 ## bn_sprinklerv.queryDo(Shoes_wet)
39 ## bn_sprinklerv.queryDo(Shoes_wet,obs={Sprinkler:"on"})
40 ## bn_sprinklerv.queryDo(Shoes_wet,do={Sprinkler:"on"})
41 ## bn_sprinklerv.queryDo(Season, obs={Sprinkler:"on"})
42 ## bn_sprinklerv.queryDo(Season, do={Sprinkler:"on"})
43
44 ### Showing posterior distributions:
45 # bn_sprinklerv.show_post({})
46 # bn_sprinklerv.show_post({Sprinkler:"on"})
47 # spon = intervene(bn_sprinkler, do={Sprinkler:"on"})
48 # ProbRC(spon).show_post({})

```

The following is a representation of a possible model where marijuana is a gateway drug to harder drugs (or not). Try the queries at the end.

```

_____probDo.py — (continued)_____
50 from variable import Variable
51 from probFactors import Prob
52 from probGraphicalModels import BeliefNetwork
53 boolean = [False, True]
54
55 Drug_Prone = Variable("Drug_Prone", boolean, position=(0.1,0.5)) #
    (0.5,0.9)
56 Side_Effects = Variable("Side_Effects", boolean, position=(0.1,0.5)) #
    (0.5,0.1)
57 Takes_Marijuana = Variable("\nTakes_Marijuana\n", boolean,
    position=(0.1,0.5))
58 Takes_Hard_Drugs = Variable("Takes_Hard_Drugs", boolean,
    position=(0.9,0.5))
59
60 p_dp = Prob(Drug_Prone, [], [0.8, 0.2])
61 p_be = Prob(Side_Effects, [Takes_Marijuana], [[1, 0], [0.4, 0.6]])
62 p_tm = Prob(Takes_Marijuana, [Drug_Prone], [[0.98, 0.02], [0.2, 0.8]])
63 p_thd = Prob(Takes_Hard_Drugs, [Side_Effects, Drug_Prone],
64             # Drug_Prone=False Drug_Prone=True
65             [[0.999, 0.001], [0.6, 0.4]], # Side_Effects=False

```

```

66         [[0.99999, 0.00001], [0.995, 0.005]]) # Side_Effects=True
67
68 drugs = BeliefNetwork("Gateway Drug?",
69                       [Drug_Prone, Side_Effects, Takes_Marijuana,
70                        Takes_Hard_Drugs],
71                       [p_tm, p_dp, p_be, p_thd])
72
73 drugsq = ProbRC(drugs)
74 # drugsq.queryDo(Takes_Hard_Drugs)
75 # drugsq.queryDo(Takes_Hard_Drugs, obs = {Takes_Marijuana: True})
76 # drugsq.queryDo(Takes_Hard_Drugs, obs = {Takes_Marijuana: False})
77 # drugsq.queryDo(Takes_Hard_Drugs, do = {Takes_Marijuana: True})
78 # drugsq.queryDo(Takes_Hard_Drugs, do = {Takes_Marijuana: False})
79
80 # ProbRC(drugs).show_post({})
81 # ProbRC(drugs).show_post({Takes_Marijuana: True})
82 # ProbRC(drugs).show_post({Takes_Marijuana: False})
83 # ProbRC(intervene(drugs, do={Takes_Marijuana: True})).show_post({})
84 # ProbRC(intervene(drugs, do={Takes_Marijuana: False})).show_post({})
85 # Why was that? Try the following then repeat:
86 # Drug_Prone.position=(0.5,0.9); Side_Effects.position=(0.5,0.1)

```

## 11.2 Counterfactual Example

Consider chain  $A \rightarrow B \rightarrow C$  where you want “what if  $A$  was True” or “what if  $A$  was False”. For example, suppose  $A=true$ ,  $C=true$  is observed and you want the probability of  $C$  if  $A$  were false. See Figure 11.1.

```

_____probCounterfactual.py — Counterfactual Query Example_____
11 from variable import Variable
12 from probFactors import Prob, ProbDT, IFeq, Dist
13 from probGraphicalModels import BeliefNetwork
14 from probRC import ProbRC
15 from probDo import queryDo
16
17 boolean = [False, True]

```

The following is a simple chain  $Ap \rightarrow Bp \rightarrow Cp$ . According to the probabilities,  $Bp$  is independent of  $Ap$ . This does not usually cause a problem; often parents are included because they might be relevant.

```

_____probCounterfactual.py — (continued)_____
19 # without a deterministic system
20 Ap = Variable("Ap", boolean, position=(0.2,0.8))
21 Bp = Variable("Bp", boolean, position=(0.2,0.4))
22 Cp = Variable("Cp", boolean, position=(0.2,0.0))
23 p_Ap = Prob(Ap, [], [0.5,0.5])
24 p_Bp = Prob(Bp, [Ap], [[0.6,0.4], [0.6,0.4]]) # does not depend on A!

```

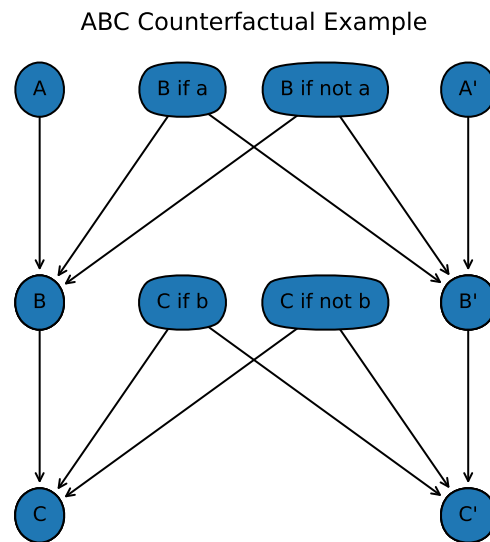

Figure 11.1:  $A \rightarrow B \rightarrow C$  belief network for “what if  $A$ ”

```

25 p_Cp = Prob(Cp, [Bp], [[0.2,0.8], [0.9,0.1]])
26 abcSimple = BeliefNetwork("ABC Simple",
27                           [Ap,Bp,Cp],
28                           [p_Ap, p_Bp, p_Cp])
29 ABCsimpq = ProbRC(abcSimple)
30 # ABCsimpq.show_post(obs = {Ap:True, Cp:True})

```

Here is the same network as a deterministic system with noise variables. The Primed variables correspond to “what if  $A$  were True” or “what if  $A$  were False”. In this scenario,  $A_{\text{prime}}$  should be conditioned on. Conditioning on  $A_{\text{prime}}$  should not affect the non-primed variables. (You should check this).

```

-----probCounterfactual.py ----- (continued) -----
32 # as a deterministic system with independent noise
33 A = Variable("A", boolean, position=(0.2,0.8))
34 B = Variable("B", boolean, position=(0.2,0.4))
35 C = Variable("C", boolean, position=(0.2,0.0))
36 Aprime = Variable("A'", boolean, position=(0.8,0.8))
37 Bprime = Variable("B'", boolean, position=(0.8,0.4))
38 Cprime = Variable("C'", boolean, position=(0.8,0.0))
39 BifA = Variable("B if a", boolean, position=(0.4,0.8))
40 BifnA = Variable("B if not a", boolean, position=(0.6,0.8))
41 CifB = Variable("C if b", boolean, position=(0.4,0.4))
42 CifnB = Variable("C if not b", boolean, position=(0.6,0.4))
43

```

```

44 # if1then2else3 is a probability table
45 # if1then2else3[x][y][z] is the deterministic probability that
46 # is the value of y if x is 1 otherwise it is the value of z
47 if1then2else3 = [[[[1,0],[0,1]],[[1,0],[0,1]]],
48                 [[1,0],[1,0]],[[0,1],[0,1]]]]
49
50
51 p_A = Prob(A, [], [0.5,0.5])
52 p_B = Prob(B, [A, BifA, BifnA], if1then2else3)
53 p_C = Prob(C, [B, CifB, CifnB], if1then2else3)
54 p_Aprime = Prob(Aprime, [], [0.5,0.5])
55 p_Bprime = Prob(Bprime, [Aprime, BifA, BifnA], if1then2else3)
56 p_Cprime = Prob(Cprime, [Bprime, CifB, CifnB], if1then2else3)
57 p_bifa = Prob(BifA, [], [0.6,0.4])
58 p_bifna = Prob(BifnA, [], [0.6,0.4])
59 p_cifb = Prob(CifB, [], [0.9,0.1])
60 p_cifnb = Prob(CifnB, [], [0.2,0.8])
61
62 abcCounter = BeliefNetwork("ABC Counterfactual Example",
63                            [A,B,C,Aprime,Bprime,Cprime,BifA, BifnA, CifB, CifnB],
64                            [p_A,p_B,p_C,p_Aprime,p_Bprime, p_Cprime, p_bifa,
                             p_bifna, p_cifb, p_cifnb])

```

Here are some queries you might like to try. The `show_post` queries might be most useful if you have the space to show multiple queries.

probCounterfactual.py — (continued)

```

66 abcq = ProbRC(abcCounter)
67 # abcq.queryDo(Cprime, obs = {Aprime:False, A:True})
68 # abcq.queryDo(Cprime, obs = {C:True, Aprime:False})
69 # abcq.queryDo(Cprime, obs = {A:True, C:True, Aprime:False})
70 # abcq.queryDo(Cprime, obs = {A:True, C:True, Aprime:False})
71 # abcq.queryDo(Cprime, obs = {A:False, C:True, Aprime:False})
72 # abcq.queryDo(CifB, obs = {C:True, Aprime:False})
73 # abcq.queryDo(CifnB, obs = {C:True, Aprime:False})
74
75 # abcq.show_post(obs = {})
76 # abcq.show_post(obs = {Aprime:False, A:True})
77 # abcq.show_post(obs = {A:True, C:True, Aprime:False})
78 # abcq.show_post(obs = {A:True, C:True, Aprime:True})

```

**Exercise 11.1** Is the above reasonable? What is surprising about this?

What if  $B$  did depend on  $A$ , but not by very much (e.g.  $P(B | A) = 0.41$ ). Is the answer then reasonable?

Are there guidelines as to when a reasonable counterfactual probability is to be expected?

### 11.2.1 Firing Squad Example

The following is the firing squad example of Pearl as a deterministic system. See Figure 11.2.

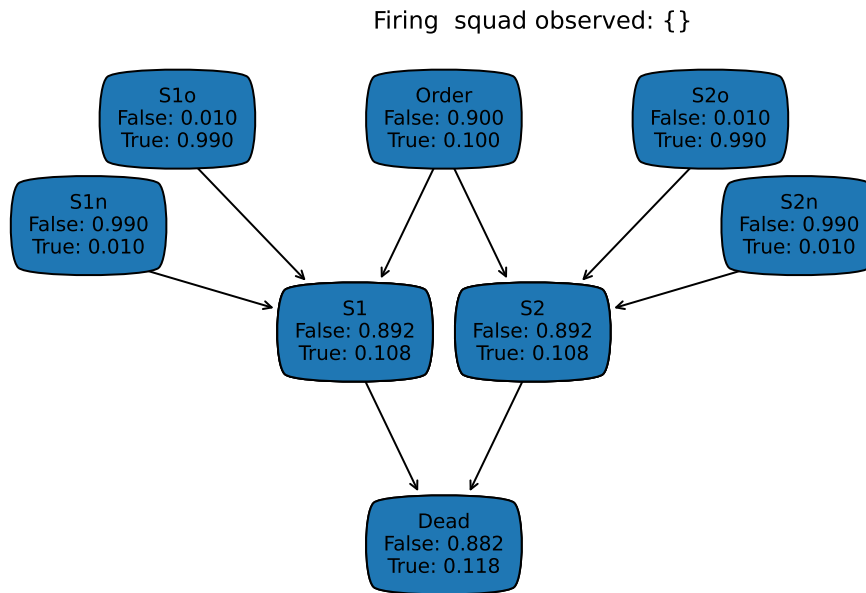

Figure 11.2: Firing squad belief network

```

probCounterfactual.py — (continued)
80 Order = Variable("Order", boolean, position=(0.4,0.8))
81 S1 = Variable("S1", boolean, position=(0.3,0.4))
82 S1o = Variable("S1o", boolean, position=(0.1,0.8))
83 S1n = Variable("S1n", boolean, position=(0.0,0.6))
84 S2 = Variable("S2", boolean, position=(0.5,0.4))
85 S2o = Variable("S2o", boolean, position=(0.7,0.8))
86 S2n = Variable("S2n", boolean, position=(0.8,0.6))
87 Dead = Variable("Dead", boolean, position=(0.4,0.0))
88
89 def eqto(var):
90     return IFeq(var,True,Dist([0,1]), Dist([1,0]))
91
92 p_S1 = ProbDT(S1, [Order, S1o, S1n],
93               IFeq(Order,True, eqto(S1o), eqto(S1n)))
94 p_S2 = ProbDT(S2, [Order, S2o, S2n],
95               IFeq(Order,True, eqto(S2o), eqto(S2n)))
96 p_dead = Prob(Dead, [S1,S2], [[[1,0],[0,1]],[[0,1],[0,1]]])
97 p_order = Prob(Order, [], [0.9, 0.1])
98 p_s1o = Prob(S1o, [], [0.01, 0.99])
99 p_s1n = Prob(S1n, [], [0.99, 0.01])
100 p_s2o = Prob(S2o, [], [0.01, 0.99])
101 p_s2n = Prob(S2n, [], [0.99, 0.01])
102

```

```

103 firing_squad = BeliefNetwork("Firing squad",
104                               [Order, S1, S1o, S1n, S2, S2o, S2n, Dead],
105                               [p_order, p_dead, p_S1, p_s1o, p_s1n, p_S2, p_s2o,
                               p_s2n])
106 fsq = ProbRC(firing_squad)
107 # fsq.queryDo(Dead)
108 # fsq.queryDo(Order, obs={Dead:True})
109 # fsq.queryDo(Dead, obs={Order:True})
110 # fsq.show_post({})
111 # fsq.show_post({Dead:True})
112 # fsq.show_post({Order:True})

```

**Exercise 11.2** Create the network for “what if shooter 2 did or did not shoot”. Give the probabilities of the following counterfactuals:

- (a) The prisoner is dead; what is the probability that the prisoner would be dead if shooter 2 did not shoot?
- (b) Shooter 2 shot; what is the probability that the prisoner would be dead if shooter 2 did not shoot?
- (c) No order was given, but the prisoner is dead; what is the probability that the prisoner would be dead if shooter 2 did not shoot?

**Exercise 11.3** Create the network for “what if the order was or was not given”. Give the probabilities of the following counterfactuals:

- (a) The prisoner is dead; what is the probability that the prisoner would be dead if the order was not given?
- (b) The prisoner is not dead; what is the probability that the prisoner would be dead if the order was not given? (Is this different from the prior that the prisoner is dead, or the posterior that the prisoner was dead given the order was not given).
- (c) Shooter 2 shot; what is the probability that the prisoner would be dead if the order was not given?
- (d) Shooter 2 did not shoot; what is the probability that the prisoner would be dead if the order was given? (Is this different from the probability that the the prisoner would be dead if the order was given without the counterfactual observation)?



## Planning with Uncertainty

### 12.1 Decision Networks

The decision network code builds on the representation for belief networks of Chapter 9.

We first allow for factors that define the utility. Here the **utility** is a function of the variables in *vars*. In a **utility table** the utility is defined in terms of a tabular factor – a list that enumerates the values – as in Section 9.3.3.

```
_____decnNetworks.py — Representations for Decision Networks _____
11 from probGraphicalModels import GraphicalModel, BeliefNetwork
12 from probFactors import Factor, CPD, TabFactor, factor_times, Prob
13 from variable import Variable
14 import matplotlib.pyplot as plt
15
16 class Utility(Factor):
17     """A factor defining a utility"""
18     pass
19
20 class UtilityTable(TabFactor, Utility):
21     """A factor defining a utility using a table"""
22     def __init__(self, vars, table, position=None):
23         """Creates a factor on vars from the table.
24         The table is ordered according to vars.
25         """
26         TabFactor.__init__(self, vars, table, name="Utility")
27         self.position = position
```

A **decision variable** is like a random variable with a string name, and a domain, which is a list of possible values. The decision variable also includes the parents, a list of the variables whose value will be known when the decision is made. It also includes a position, which is only used for plotting.

```

decnNetworks.py — (continued)
29 class DecisionVariable(Variable):
30     def __init__(self, name, domain, parents, position=None):
31         Variable.__init__(self, name, domain, position)
32         self.parents = parents
33         self.all_vars = set(parents) | {self}

```

A decision network is a graphical model where the variables can be random variables or decision variables. Among the factors we assume there is one utility factor.

```

decnNetworks.py — (continued)
35 class DecisionNetwork(BeliefNetwork):
36     def __init__(self, title, vars, factors):
37         """vars is a list of variables
38         factors is a list of factors (instances of CPD and Utility)
39         """
40         GraphicalModel.__init__(self, title, vars, factors) # don't call
41         init for BeliefNetwork
42         self.var2parents = ({v : v.parents for v in vars if
43             isinstance(v,DecisionVariable)}
44             | {f.child:f.parents for f in factors if
45             isinstance(f,CPD)})
46         self.children = {n:[] for n in self.variables}
47         for v in self.var2parents:
48             for par in self.var2parents[v]:
49                 self.children[par].append(v)
50         self.utility_factor = [f for f in factors if
51             isinstance(f,Utility)][0]
52         self.topological_sort_saved = None
53
54     def __str__(self):
55         return self.title

```

The split order ensures that the parents of a decision node are split before the decision node, and no other variables (if that is possible).

```

decnNetworks.py — (continued)
53     def split_order(self):
54         so = []
55         tops = self.topological_sort()
56         for v in tops:
57             if isinstance(v,DecisionVariable):
58                 so += [p for p in v.parents if p not in so]
59                 so.append(v)
60         so += [v for v in tops if v not in so]
61         return so

```

```

decnNetworks.py — (continued)
63     def show(self, fontsize=10,

```

```

64         colors={'utility':'red', 'decision':'lime',
65                'random':'orange'} ):
66     plt.ion() # interactive
67     ax = plt.figure().gca()
68     ax.set_axis_off()
69     plt.title(self.title, fontsize=fontsize)
70     for par in self.utility_factor.variables:
71         ax.annotate("Utility", par.position,
72                    xytext=self.utility_factor.position,
73                    arrowprops={'arrowstyle':'<-'},
74                    bbox=dict(boxstyle="sawtooth,pad=1.0",color=colors['utility']),
75                    ha='center', va='center',
76                    fontsize=fontsize)
77     for var in reversed(self.topological_sort()):
78         if isinstance(var,DecisionVariable):
79             bbox =
80                 dict(boxstyle="square,pad=1.0",color=colors['decision'])
81         else:
82             bbox =
83                 dict(boxstyle="round4,pad=1.0,rounding_size=0.5",color=colors['random'])
84         if self.var2parents[var]:
85             for par in self.var2parents[var]:
86                 ax.annotate(var.name, par.position, xytext=var.position,
87                            arrowprops={'arrowstyle':'<-'},bbox=bbox,
88                            ha='center', va='center',
89                            fontsize=fontsize)
90         else:
91             x,y = var.position
92             plt.text(x,y,var.name,bbox=bbox,ha='center', va='center',
93                    fontsize=fontsize)

```

### 12.1.1 Example Decision Networks

#### Umbrella Decision Network

Here is a simple “umbrella” decision network. The output of `umbrella_dn.show()` is shown in Figure 12.1.

```

decnNetworks.py — (continued)
88 Weather = Variable("Weather", ["NoRain", "Rain"], position=(0.5,0.8))
89 Forecast = Variable("Forecast", ["Sunny", "Cloudy", "Rainy"],
90                    position=(0,0.4))
91 # Each variant uses one of the following:
92 Umbrella = DecisionVariable("Umbrella", ["Take", "Leave"], {Forecast},
93                             position=(0.5,0))
94 p_weather = Prob(Weather, [], {"NoRain":0.7, "Rain":0.3})
95 p_forecast = Prob(Forecast, [Weather], {"NoRain":{"Sunny":0.7,
96 "Cloudy":0.2, "Rainy":0.1},

```

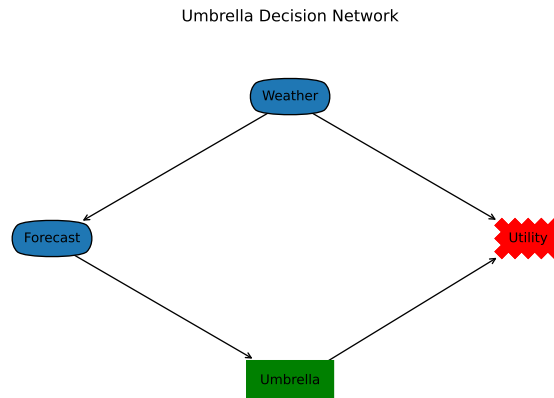

Figure 12.1: The umbrella decision network

```

95         "Rain":{"Sunny":0.15,
96         "Cloudy":0.25, "Rainy":0.6}})
umb_utility = UtilityTable([Weather, Umbrella], {"NoRain":{"Take":20,
97         "Leave":100},
98         "Rain":{"Take":70,
99         "Leave":0}},
100         position=(1,0.4))
umbrella_dn = DecisionNetwork("Umbrella Decision Network",
101         {Weather, Forecast, Umbrella},
102         {p_weather, p_forecast, umb_utility})
103 # umbrella_dn.show()
104 # umbrella_dn.show(fontsize=15)

```

The following is a variant with the umbrella decision having 2 parents; nothing else has changed. This is interesting because one of the parents is not needed; if the agent knows the weather, it can ignore the forecast.

```

----- decnNetworks.py --- (continued) -----
106 Umbrella2p = DecisionVariable("Umbrella", ["Take", "Leave"], {Forecast,
107         Weather}, position=(0.5,0))
umb_utility2p = UtilityTable([Weather, Umbrella2p], {"NoRain":{"Take":20,
108         "Leave":100},
109         "Rain":{"Take":70,
110         "Leave":0}},
111         position=(1,0.4))
umbrella_dn2p = DecisionNetwork("Umbrella Decision Network (extra arc)",
112         {Weather, Forecast, Umbrella2p},
113         {p_weather, p_forecast, umb_utility2p})
# umbrella_dn2p.show()

```

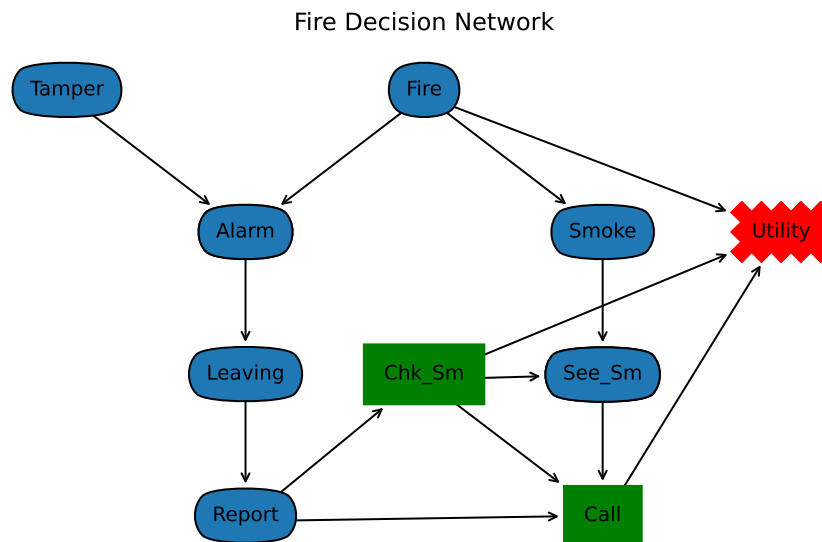

Figure 12.2: Fire Decision Network

```
114 | # umbrella_dn2p.show(fontsize=15)
```

### Fire Decision Network

The fire decision network of Figure 12.2 (showing the result of `fire_dn.show()`) is represented as:

decnNetworks.py — (continued)

```

116 | boolean = [False, True]
117 | Alarm = Variable("Alarm", boolean, position=(0.25,0.633))
118 | Fire = Variable("Fire", boolean, position=(0.5,0.9))
119 | Leaving = Variable("Leaving", boolean, position=(0.25,0.366))
120 | Report = Variable("Report", boolean, position=(0.25,0.1))
121 | Smoke = Variable("Smoke", boolean, position=(0.75,0.633))
122 | Tamper = Variable("Tamper", boolean, position=(0,0.9))
123 |
124 | See_Sm = Variable("See_Sm", boolean, position=(0.75,0.366) )
125 | Chk_Sm = DecisionVariable("Chk_Sm", boolean, {Report}, position=(0.5,
126 |     0.366))
127 | Call = DecisionVariable("Call", boolean,{See_Sm,Chk_Sm,Report},
128 |     position=(0.75,0.1))
127 |
128 | f_ta = Prob(Tamper,[],[0.98,0.02])

```

```

129 f-fi = Prob(Fire,[],[0.99,0.01])
130 f-sm = Prob(Smoke,[Fire],[[0.99,0.01],[0.1,0.9]])
131 f-al = Prob(Alarm,[Fire,Tamper],[[0.9999, 0.0001], [0.15, 0.85]], [[0.01,
    0.99], [0.5, 0.5]])
132 f-lv = Prob(Leaving,[Alarm],[[0.999, 0.001], [0.12, 0.88]])
133 f-re = Prob(Report,[Leaving],[[0.99, 0.01], [0.25, 0.75]])
134 f-ss = Prob(See_Sm,[Chk_Sm,Smoke],[[1,0],[1,0]],[[1,0],[0,1]])
135
136 ut = UtilityTable([Chk_Sm,Fire,Call],
137                 [[0,-200],[-5000,-200]],[[-20,-220],[-5020,-220]]],
138                 position=(1,0.633))
139
140 fire-dn = DecisionNetwork("Fire Decision Network",
141                          {Tamper,Fire,Alarm,Leaving,Smoke,Call,See_Sm,Chk_Sm,Report},
142                          {f-ta,f-fi,f-sm,f-al,f-lv,f-re,f-ss,ut})
143
144 # print(ut.to_table())
145 # fire-dn.show()
146 # fire-dn.show(fontsize=15)

```

### Cheating Decision Network

The following is the representation of the cheating decision of Figure 12.3. Note that we keep the names of the variables short (less than 8 characters) so that the tables look good when printed.

```

-----decnNetworks.py --- (continued)-----
148 grades = ['A', 'B', 'C', 'F']
149 Watched = Variable("Watched", boolean, position=(0,0.9))
150 Caught1 = Variable("Caught1", boolean, position=(0.2,0.7))
151 Caught2 = Variable("Caught2", boolean, position=(0.6,0.7))
152 Punish = Variable("Punish", ["None","Suspension","Recorded"],
    position=(0.8,0.9))
153 Grade_1 = Variable("Grade_1", grades, position=(0.2,0.3))
154 Grade_2 = Variable("Grade_2", grades, position=(0.6,0.3))
155 Fin_Grd = Variable("Fin_Grd", grades, position=(0.8,0.1))
156 Cheat_1 = DecisionVariable("Cheat_1", boolean, set(), position=(0,0.5))
    #no parents
157 Cheat_2 = DecisionVariable("Cheat_2", boolean, {Cheat_1,Caught1},
    position=(0.4,0.5))
158
159 p-wa = Prob(Watched,[],[0.7, 0.3])
160 p-cc1 = Prob(Caught1,[Watched,Cheat_1],[[1.0, 0.0], [0.9, 0.1]], [[1.0,
    0.0], [0.5, 0.5]])
161 p-cc2 = Prob(Caught2,[Watched,Cheat_2],[[1.0, 0.0], [0.9, 0.1]], [[1.0,
    0.0], [0.5, 0.5]])
162 p-pun = Prob(Punish,[Caught1,Caught2],
163             [{"None":0,"Suspension":0,"Recorded":0},
164             {"None":0.5,"Suspension":0.4,"Recorded":0.1}],
165             [{"None":0.6,"Suspension":0.2,"Recorded":0.2}],

```

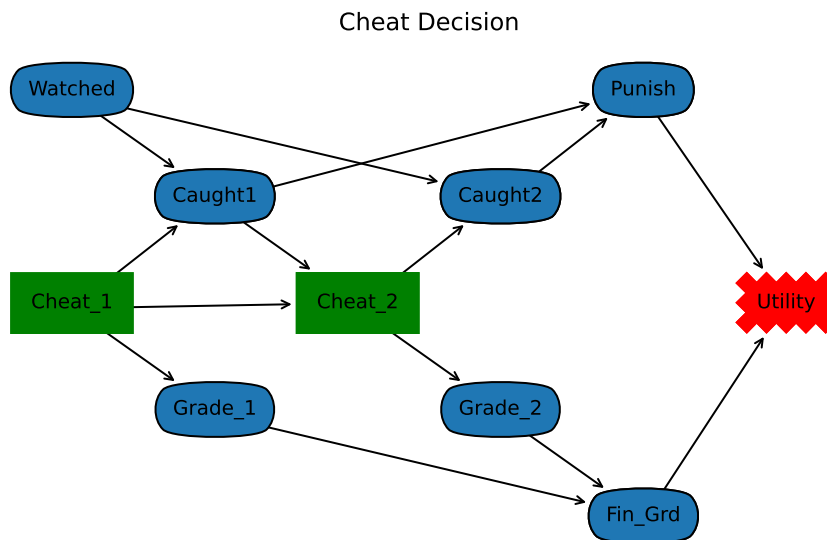

Figure 12.3: Cheating Decision Network

```

166         {"None":0.2,"Suspension":0.3,"Recorded":0.3}]]]
167 p_gr1 = Prob(Grade_1,[Cheat_1], [{"A":0.2, 'B':0.3, 'C':0.3, 'F': 0.2},
168         {'A':0.5, 'B':0.3, 'C':0.2, 'F':0.0}])
169 p_gr2 = Prob(Grade_2,[Cheat_2], [{"A":0.2, 'B':0.3, 'C':0.3, 'F': 0.2},
170         {'A':0.5, 'B':0.3, 'C':0.2, 'F':0.0}])
171 p_fg = Prob(Fin_Grd,[Grade_1,Grade_2],
172         {'A':{'A':1.0, 'B':0.0, 'C': 0.0, 'F':0.0},
173          'B': {'A':0.5, 'B':0.5, 'C': 0.0, 'F':0.0},
174          'C':{'A':0.25, 'B':0.5, 'C': 0.25, 'F':0.0},
175          'F':{'A':0.25, 'B':0.25, 'C': 0.25, 'F':0.25}},
176         'B':{'A':{'A':0.5, 'B':0.5, 'C': 0.0, 'F':0.0},
177          'B': {'A':0.0, 'B':1, 'C': 0.0, 'F':0.0},
178          'C':{'A':0.0, 'B':0.5, 'C': 0.5, 'F':0.0},
179          'F':{'A':0.0, 'B':0.25, 'C': 0.5, 'F':0.25}},
180         'C':{'A':{'A':0.25, 'B':0.5, 'C': 0.25, 'F':0.0},
181          'B': {'A':0.0, 'B':0.5, 'C': 0.5, 'F':0.0},
182          'C':{'A':0.0, 'B':0.0, 'C': 1, 'F':0.0},
183          'F':{'A':0.0, 'B':0.0, 'C': 0.5, 'F':0.5}},
184         'F':{'A':{'A':0.25, 'B':0.25, 'C': 0.25, 'F':0.25},
185          'B': {'A':0.0, 'B':0.25, 'C': 0.5, 'F':0.25},
186          'C':{'A':0.0, 'B':0.0, 'C': 0.5, 'F':0.5},
187          'F':{'A':0.0, 'B':0.0, 'C': 0, 'F':1.0}}})
188
189 utc = UtilityTable([Punish,Fin_Grd],

```

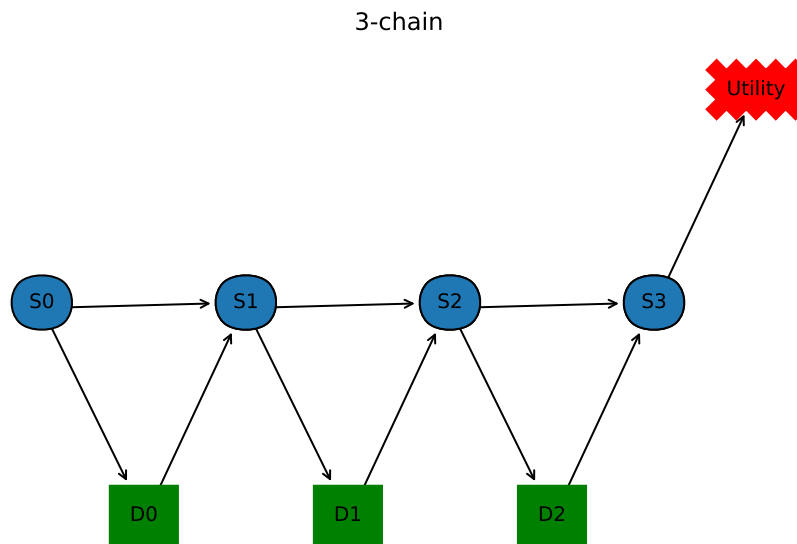

Figure 12.4: A decision network that is a chain of 3 decisions

```

190         {'None':{'A':100, 'B':90, 'C': 70, 'F':50},
191          'Suspension':{'A':40, 'B':20, 'C': 10, 'F':0},
192          'Recorded':{'A':70, 'B':60, 'C': 40, 'F':20}},
193         position=(1,0.5))
194
195 cheating_dn = DecisionNetwork("Cheating Decision Network",
196                               {Punish,Caught2,Watched,Fin_Grd,Grade_2,Grade_1,Cheat_2,Caught1,Cheat_1},
197                               {p_wa, p_cc1, p_cc2, p_pun, p_gr1, p_gr2,p_fg,utc})
198
199 # cheating_dn.show()
200 # cheating_dn.show(fontsize=15)

```

### Chain of 3 decisions

The following example is a finite-stage fully-observable Markov decision process with a single reward (utility) at the end. It is interesting because the parents do not include all predecessors. The methods we use will work without change on this, even though the agent does not condition on all of its previous observations and actions. The output of `ch3.show()` is shown in Figure 12.4.

```

----- decnNetworks.py --- (continued) -----
202 S0 = Variable('S0', boolean, position=(0,0.5))
203 D0 = DecisionVariable('D0', boolean, {S0}, position=(1/7,0.1))
204 S1 = Variable('S1', boolean, position=(2/7,0.5))

```

```

205 D1 = DecisionVariable('D1', boolean, {S1}, position=(3/7,0.1))
206 S2 = Variable('S2', boolean, position=(4/7,0.5))
207 D2 = DecisionVariable('D2', boolean, {S2}, position=(5/7,0.1))
208 S3 = Variable('S3', boolean, position=(6/7,0.5))
209
210 p_s0 = Prob(S0, [], [0.5,0.5])
211 tr = [[[0.1, 0.9], [0.9, 0.1]], [[0.2, 0.8], [0.8, 0.2]]] # 0 is flip, 1
    is keep value
212 p_s1 = Prob(S1, [D0,S0], tr)
213 p_s2 = Prob(S2, [D1,S1], tr)
214 p_s3 = Prob(S3, [D2,S2], tr)
215
216 ch3U = UtilityTable([S3],[0,1], position=(7/7,0.9))
217
218 ch3 = DecisionNetwork("3-chain",
    {S0,D0,S1,D1,S2,D2,S3},{p_s0,p_s1,p_s2,p_s3,ch3U})
219
220 # ch3.show()
221 # ch3.show(fontsize=15)

```

### 12.1.2 Decision Functions

The output of an optimization function is an optimal policy, a list of decision functions, and the expected value of the optimal policy. A decision function is the action for each decision variable as a function of its parents.

decnNetworks.py — (continued)

```

223 class DictFactor(Factor):
224     """A factor the represents the values using a dicionary"""
225     def __init__(self, *pargs, **kwargs):
226         self.values = {}
227         Factor.__init__(self, *pargs, **kwargs)
228
229     def assign(self, assignment, value):
230         self.values[frozenset(assignment.items())] = value
231
232     def get_value(self, assignment):
233         ass = frozenset(assignment.items())
234         assert ass in self.values, f"assignment {assignment} cannot be
            evaluated"
235         return self.values[ass]
236
237 class DecisionFunction(DictFactor):
238     def __init__(self, decision, parents):
239         """ A decision function
240         decision is a decision variable
241         parents is a set of variables
242         """
243         self.decision = decision
244         self.parent = parents

```

```
245 DictFactor.__init__(self, parents, name=decision.name)
```

### 12.1.3 Recursive Conditioning for decision networks

An instance of a RC\_DN object takes in a decision network. The query method uses recursive conditioning to compute the expected utility of the optimal policy. `self.opt_policy` becomes the optimal policy.

```

-----decnNetworks.py — (continued)-----
247 import math
248 from probGraphicalModels import GraphicalModel, InferenceMethod
249 from probFactors import Factor
250 from probRC import connected_components
251
252 class RC_DN(InferenceMethod):
253     """The class that queries graphical models using recursive conditioning
254
255     gm is graphical model to query
256     """
257
258     def __init__(self, gm=None):
259         self.gm = gm
260         self.cache = {(frozenset(), frozenset()):1}
261         ## self.max_display_level = 3
262
263     def optimize(self, split_order=None, algorithm=None):
264         """computes expected utility, and creates optimal decision
265         functions, where
266
267         elim_order is a list of the non-observed non-query variables in gm
268         algorithm is the (search algorithm to use). Default is self.rc
269         """
270         if algorithm is None:
271             algorithm = self.rc
272         if split_order == None:
273             split_order = self.gm.split_order()
274         self.opt_policy = {v:DecisionFunction(v, v.parents)
275                             for v in self.gm.variables
276                             if isinstance(v, DecisionVariable)}
277         return algorithm({}, self.gm.factors, split_order)
278
279     def show_policy(self):
280         print('\n'.join(df.to_table() for df in self.opt_policy.values()))

```

The following uses the simplest search-based algorithm. It is exponential in the number of variables, so is not very useful. However, it is simple, and useful to understand before looking at the more complicated algorithm. Note that the above code does not call `rc0`; you will need to change the `self.rc` to `self.rc0` in above code to use it.

```
-----decnNetworks.py — (continued)-----
```

```

280 def rc0(self, context, factors, split_order):
281     """simplest search algorithm
282     context is a variable:value dictionary
283     factors is a set of factors
284     split_order is a list of variables in factors that are not in
        context
285     """
286     self.display(3,"calling rc0,", (context,factors),"with
        SO",split_order)
287     if not factors:
288         return 1
289     elif to_eval := {fac for fac in factors if
        fac.can_evaluate(context)}:
290         self.display(3,"rc0 evaluating factors",to_eval)
291         val = math.prod(fac.get_value(context) for fac in to_eval)
292         return val * self.rc0(context, factors-to_eval, split_order)
293     else:
294         var = split_order[0]
295         self.display(3, "rc0 branching on", var)
296         if isinstance(var,DecisionVariable):
297             assert set(context) <= set(var.parents), f"cannot optimize
                {var} in context {context}"
298             maxres = -math.inf
299             for val in var.domain:
300                 self.display(3,"In rc0, branching on",var,"=",val)
301                 newres = self.rc0({var:val}|context, factors,
                    split_order[1:])
302                 if newres > maxres:
303                     maxres = newres
304                     theval = val
305                 self.opt_policy[var].assign(context,theval)
306             return maxres
307         else:
308             total = 0
309             for val in var.domain:
310                 total += self.rc0({var:val}|context, factors,
                    split_order[1:])
311             self.display(3, "rc0 branching on", var,"returning", total)
312             return total

```

We can combine the optimization for decision networks above, with the improvements of recursive conditioning used for graphical models (Section 9.7, page 220).

decnNetworks.py — (continued)

```

314 def rc(self, context, factors, split_order):
315     """ returns the number  $\sum_{\text{split\_order}} \prod_{\text{factors}}$  given
        assignments in context
316     context is a variable:value dictionary
317     factors is a set of factors

```

```

318 |     split_order is a list of variables in factors that are not in
      |         context
319 |     """
320 |     self.display(3,"calling rc,", (context,factors))
321 |     ce = (frozenset(context.items()), frozenset(factors)) # key for the
      |         cache entry
322 |     if ce in self.cache:
323 |         self.display(2,"rc cache lookup", (context,factors))
324 |         return self.cache[ce]
325 | #     if not factors: # no factors; needed if you don't have forgetting
      | and caching
326 | #         return 1
327 |     elif vars_not_in_factors := {var for var in context
328 |                                 if not any(var in fac.variables for
      |                                     fac in factors)}:
329 |         # forget variables not in any factor
330 |         self.display(3,"rc forgetting variables", vars_not_in_factors)
331 |         return self.rc({key:val for (key,val) in context.items()
332 |                         if key not in vars_not_in_factors},
333 |                        factors, split_order)
334 |     elif to_eval := {fac for fac in factors if
      |                     fac.can_evaluate(context)}:
335 |         # evaluate factors when all variables are assigned
336 |         self.display(3,"rc evaluating factors",to_eval)
337 |         val = math.prod(fac.get_value(context) for fac in to_eval)
338 |         if val == 0:
339 |             return 0
340 |         else:
341 |             return val * self.rc(context, {fac for fac in factors if fac
      |                                     not in to_eval}, split_order)
342 |     elif len(comp := connected_components(context, factors,
      | split_order)) > 1:
343 |         # there are disconnected components
344 |         self.display(2,"splitting into connected components",comp)
345 |         return(math.prod(self.rc(context,f,eo) for (f,eo) in comp))
346 |     else:
347 |         assert split_order, f"split_order empty rc({context},{factors})"
348 |         var = split_order[0]
349 |         self.display(3, "rc branching on", var)
350 |         if isinstance(var,DecisionVariable):
351 |             assert set(context) <= set(var.parents), f"cannot optimize
      | {var} in context {context}"
352 |             maxres = -math.inf
353 |             for val in var.domain:
354 |                 self.display(3,"In rc, branching on",var,"=",val)
355 |                 newres = self.rc({var:val}|context, factors,
      |                                 split_order[1:])
356 |                 if newres > maxres:
357 |                     maxres = newres
358 |                 theval = val

```

```

359         self.opt_policy[var].assign(context,theval)
360         self.cache[ce] = maxres
361         return maxres
362     else:
363         total = 0
364         for val in var.domain:
365             total += self.rc({var:val}|context, factors,
366                             split_order[1:])
367         self.display(3, "rc branching on", var,"returning", total)
368         self.cache[ce] = total
369         return total

```

Here is how to run the optimize the example decision networks:

```

-----decnNetworks.py --- (continued) -----
370 # Umbrella decision network
371 #urc = RC_DN(umbrella_dn)
372 #urc.optimize(algorithm=urc.rc0) #RC0
373 #urc.optimize() #RC
374 #urc.show_policy()
375
376 #rc_fire = RC_DN(fire_dn)
377 #rc_fire.optimize()
378 #rc_fire.show_policy()
379
380 #rc_cheat = RC_DN(cheating_dn)
381 #rc_cheat.optimize()
382 #rc_cheat.show_policy()
383
384 #rc_ch3 = RC_DN(ch3)
385 #rc_ch3.optimize()
386 #rc_ch3.show_policy()
387 # rc_ch3.optimize(algorithm=rc_ch3.rc0) # why does that happen?

```

#### 12.1.4 Variable elimination for decision networks

VE\_DN is variable elimination for decision networks. The method *optimize* is used to optimize all the decisions. Note that *optimize* requires a legal elimination ordering of the random and decision variables, otherwise it will give an exception. (A decision node can only be maximized if the variables that are not its parents have already been eliminated.)

```

-----decnNetworks.py --- (continued) -----
389 from probVE import VE
390
391 class VE_DN(VE):
392     """Variable Elimination for Decision Networks"""
393     def __init__(self,dn=None):
394         """dn is a decision network"""
395         VE.__init__(self,dn)

```

```

396     self.dn = dn
397
398     def optimize(self, elim_order=None, obs={}):
399         if elim_order == None:
400             elim_order = reversed(self.gm.split_order())
401         self.opt_policy = {}
402         proj_factors = [self.project_observations(fact, obs)
403                        for fact in self.dn.factors]
404         for v in elim_order:
405             if isinstance(v, DecisionVariable):
406                 to_max = [fac for fac in proj_factors
407                          if v in fac.variables and set(fac.variables) <=
408                             v.all_vars]
409                 assert len(to_max)==1, "illegal variable order
410                    "+str(elim_order)+" at "+str(v)
411                 newFac = FactorMax(v, to_max[0])
412                 self.opt_policy[v]=newFac.decision_fun
413                 proj_factors = [fac for fac in proj_factors if fac is not
414                               to_max[0]]+[newFac]
415                 self.display(2, "maximizing", v )
416                 self.display(3, newFac)
417             else:
418                 proj_factors = self.eliminate_var(proj_factors, v)
419             assert len(proj_factors)==1, "Should there be only one element of
420                proj_factors?"
421         return proj_factors[0].get_value({})
422
423     def show_policy(self):
424         print('\n'.join(df.to_table() for df in self.opt_policy.values()))

```

decnNetworks.py — (continued)

```

422 class FactorMax(TabFactor):
423     """A factor obtained by maximizing a variable in a factor.
424     Also builds a decision_function. This is based on FactorSum.
425     """
426
427     def __init__(self, dvar, factor):
428         """dvar is a decision variable.
429         factor is a factor that contains dvar and only parents of dvar
430         """
431         self.dvar = dvar
432         self.factor = factor
433         vars = [v for v in factor.variables if v is not dvar]
434         Factor.__init__(self, vars)
435         self.values = {}
436         self.decision_fun = DecisionFunction(dvar, dvar.parents)
437
438     def get_value(self, assignment):
439         """lazy implementation: if saved, return saved value, else compute
440            it"""

```

```

440     new_asst = {x:v for (x,v) in assignment.items() if x in
         self.variables}
441     asst = frozenset(new_asst.items())
442     if asst in self.values:
443         return self.values[asst]
444     else:
445         max_val = float("-inf") # -infinity
446         for elt in self.dvar.domain:
447             fac_val = self.factor.get_value(assignment|{self.dvar:elt})
448             if fac_val>max_val:
449                 max_val = fac_val
450                 best_elt = elt
451         self.values[asst] = max_val
452         self.decision_fun.assign(assignment, best_elt)
453         return max_val

```

Here are some example queries:

```

decnNetworks.py — (continued)
455 # Example queries:
456 # vf = VE_DN(fire_dn)
457 # vf.optimize()
458 # vf.show_policy()
459
460 # VE_DN.max_display_level = 3 # if you want to show lots of detail
461 # vc = VE_DN(cheating_dn)
462 # vc.optimize()
463 # vc.show_policy()
464
465
466 def test(dn):
467     rc0dn = RC_DN(dn)
468     rc0v = rc0dn.optimize(algorithm=rc0dn.rc0)
469     rcdn = RC_DN(dn)
470     rcv = rcdn.optimize()
471     assert abs(rc0v-rcv)<1e-10, f"rc0 produces {rc0v}; rc produces {rcv}"
472     vedn = VE_DN(dn)
473     vev = vedn.optimize()
474     assert abs(vev-rcv)<1e-10, f"VE_DN produces {vev}; RC produces {rcv}"
475     print(f"passed unit test. rc0, rc and VE gave same result for {dn}")
476
477 if __name__ == "__main__":
478     test(fire_dn)

```

## 12.2 Markov Decision Processes

The following represent a **Markov decision process (MDP)** directly, rather than using the recursive conditioning or variable elimination code, as was done for decision networks.

```

mdpProblem.py — Representations for Markov Decision Processes
11 import random
12 from display import Displayable
13 from utilities import argmaxd
14
15 class MDP(Displayable):
16     """A Markov Decision Process. Must define:
17     title a string that gives the title of the MDP
18     states the set (or list) of states
19     actions the set (or list) of actions
20     discount a real-valued discount
21     """
22
23     def __init__(self, title, states, actions, discount, init=0):
24         self.title = title
25         self.states = states
26         self.actions = actions
27         self.discount = discount
28         self.initv = self.V = {s:init for s in self.states}
29         self.initq = self.Q = {s: {a: init for a in self.actions} for s in
30             self.states}
31
32     def P(self,s,a):
33         """Transition probability function
34         returns a dictionary of {s1:p1} such that P(s1 | s,a)=p1. Other
35         probabilities are zero.
36         """
37         raise NotImplementedError("P") # abstract method
38
39     def R(self,s,a):
40         """Reward function R(s,a)
41         returns the expected reward for doing a in state s.
42         """
43         raise NotImplementedError("R") # abstract method

```

Two state partying example (Example 12.29 in Poole and Mackworth [2023]):

```

mdpExamples.py — MDP Examples
11 from mdpProblem import MDP, ProblemDomain, distribution
12 from mdpGUI import GridDomain
13 import matplotlib.pyplot as plt
14
15 class partyMDP(MDP):
16     """Simple 2-state, 2-Action Partying MDP Example"""
17     def __init__(self, discount=0.9):
18         states = {'healthy', 'sick'}
19         actions = {'relax', 'party'}
20         MDP.__init__(self, "party MDP", states, actions, discount)
21
22     def R(self,s,a):

```

```

23     "R(s,a)"
24     return { 'healthy': {'relax': 7, 'party': 10},
25             'sick':    {'relax': 0, 'party': 2 }}[s][a]
26
27     def P(self,s,a):
28         "returns a dictionary of {s1:p1} such that P(s1 | s,a)=p1. Other
29         probabilities are zero."
30         phealthy = { # P('healthy' | s, a)
31                     'healthy': {'relax': 0.95, 'party': 0.7},
32                     'sick':    {'relax': 0.5, 'party': 0.1 }}[s][a]
33         return {'healthy':phealthy, 'sick':1-phealthy}

```

The distribution class is used to represent distributions as they are being created. Probability distributions are represented as item:value dictionaries. When being constructed, adding an item:value to the dictionary has to act differently when the item is already in the dictionary and when it isn't. The `add_prob` method works whether the item is in the dictionary or not.

mdpProblem.py — (continued)

```

43 class distribution(dict):
44     """A distribution is an item:prob dictionary.
45     The only new part is when a new item:pr is added, and item is already
46     there, the values are summed
47     """
48     def __init__(self,d):
49         dict.__init__(self,d)
50
51     def add_prob(self, item, pr):
52         if item in self:
53             self[item] += pr
54         else:
55             self[item] = pr
56         return self

```

### 12.2.1 Problem Domains

An MDP does not contain enough information to simulate a domain, because

- (a) the rewards and resulting state can be correlated (e.g., in the grid domains below, crashing into a wall results in both a negative reward and the agent not moving), and
- (b) it represents the *expected* reward (e.g., a reward of 1 is has the same expected value as as a reward of 100 with probability 1/100 and 0 otherwise, but these are different in a simulation).

A problem domain represents a problem as a function result from states and actions into a distribution of (*state, reward*) pairs. This can be a subclass of MDP because it implements `R` and `P`. A problem domain also specifies an initial state and coordinate information used by the graphical user interfaces.

```

mdpProblem.py — (continued)
57 class ProblemDomain(MDP):
58     """A ProblemDomain implements
59     self.result(state, action) -> {(reward, state):probability}.
60     Other pairs have probability are zero.
61     The probabilities must sum to 1.
62     """
63     def __init__(self, title, states, actions, discount,
64                 initial_state=None, x_dim=0, y_dim = 0,
65                 vinit=0, offsets={}):
66         """A problem domain
67         * title is list of titles
68         * states is the list of states
69         * actions is the list of actions
70         * discount is the discount factor
71         * initial_state is the state the agent starts at (for simulation)
72           if known
73         * x_dim and y_dim are the dimensions used by the GUI to show the
74           states in 2-dimensions
75         * vinit is the initial value
76         * offsets is a {action:(x,y)} map which specifies how actions are
77           displayed in GUI
78         """
79         MDP.__init__(self, title, states, actions, discount)
80         if initial_state is not None:
81             self.state = initial_state
82         else:
83             self.state = random.choice(states)
84         self.vinit = vinit # value to reset v,q to
85         # The following are for the GUI:
86         self.x_dim = x_dim
87         self.y_dim = y_dim
88         self.offsets = offsets
89
90     def state2pos(self, state):
91         """When displaying as a grid, this specifies how the state is
92         mapped to (x,y) position.
93         The default is for domains where the (x,y) position is the state
94         """
95         return state
96
97     def state2goal(self, state):
98         """When displaying as a grid, this specifies how the state is
99         mapped to goal position.
100        The default is for domains where there is no goal
101        """
102        return None
103
104     def pos2state(self, pos):
105         """When displaying as a grid, this specifies how the state is

```

```

    mapped to (x,y) position.
101     The default is for domains where the (x,y) position is the state
102     """
103     return pos
104
105     def P(self, state, action):
106         """Transition probability function
107         returns a dictionary of {s1:p1} such that P(s1 | state,action)=p1.
108         Other probabilities are zero.
109         """
110         res = self.result(state, action)
111         acc = 1e-6 # accuracy for test of equality
112         assert 1-acc<sum(res.values())<1+acc, f"result({state},{action})
113             not a distribution, sum={sum(res.values())}"
114         dist = distribution({})
115         for ((r,s),p) in res.items():
116             dist.add_prob(s,p)
117         return dist
118
119     def R(self, state, action):
120         """Reward function R(s,a)
121         returns the expected reward for doing a in state s.
122         """
123         return sum(r*p for ((r,s),p) in self.result(state, action).items())

```

## Tiny Game

The next example is the tiny game from Example 13.1 and Figure 13.1 of Poole and Mackworth [2023]. The state is represented as  $(x,y)$  where  $x$  counts from zero from the left, and  $y$  counts from zero upwards, so the state  $(0,0)$  is on the bottom-left state. The actions are upC for up-careful, upR for up-risky, left, and left. (Note that GridDomain means that it can be shown with the MDP GUI in Section 12.2.3).

```

_____mdpExamples.py — (continued)_____
34 class MDPTiny(ProblemDomain, GridDomain):
35     def __init__(self, discount=0.9):
36         x_dim = 2 # x-dimension
37         y_dim = 3
38         ProblemDomain.__init__(self,
39             "Tiny MDP", # title
40             [(x,y) for x in range(x_dim) for y in range(y_dim)], #states
41             ['right', 'upC', 'left', 'upR'], #actions
42             discount,
43             x_dim=x_dim, y_dim = y_dim,
44             offsets = {'right':(0.25,0), 'upC':(0,-0.25), 'left':(-0.25,0),
45                       'upR':(0,0.25)}
46         )

```

```

47 def result(self, state, action):
48     """return a dictionary of {(r,s):p} where p is the probability of
        reward r, state s
49     a state is an (x,y) pair
50     """
51     (x,y) = state
52     right = (-x,(1,y)) # reward is -1 if x was 1
53     left = (0,(0,y)) if x==1 else [(-1,(0,0)), (-100,(0,1)),
        (10,(0,0))][y]
54     up = (0,(x,y+1)) if y<2 else (-1,(x,y))
55     if action == 'right':
56         return {right:1}
57     elif action == 'upC':
58         (r,s) = up
59         return {(r-1,s):1}
60     elif action == 'left':
61         return {left:1}
62     elif action == 'upR':
63         return distribution({left:
            0.1}).add_prob(right,0.1).add_prob(up,0.8)
64         # Exercise: what is wrong with return {left: 0.1, right:0.1,
            up:0.8}
65
66 # To show GUI do
67 # MDptiny().viGUI()

```

## Grid World

Here is the domain of Example 12.30 of Poole and Mackworth [2023], shown here in Figure 12.5. A state is represented as  $(x,y)$  where  $x$  counts from zero from the left, and  $y$  counts from zero upwards, so the state  $(0,0)$  is on the bottom-left.

```

_____mdpExamples.py — (continued)_____
69 class grid(ProblemDomain, GridDomain):
70     """ x_dim * y_dim grid with rewarding states"""
71     def __init__(self, discount=0.9, x_dim=10, y_dim=10):
72         ProblemDomain.__init__(self,
73             "Grid World",
74             [(x,y) for x in range(y_dim) for y in range(y_dim)], #states
75             ['up', 'down', 'right', 'left'], #actions
76             discount,
77             x_dim = x_dim, y_dim = y_dim,
78             offsets = {'right':(0.25,0), 'up':(0,0.25), 'left':(-0.25,0),
                'down':(0,-0.25)})
79         self.rewarding_states = {(3,2):-10, (3,5):-5, (8,2):10, (7,7):3 }
80         self.fling_states = {(8,2), (7,7)} # assumed a subset of
            rewarding_states
81
82     def intended_next(self,s,a):

```

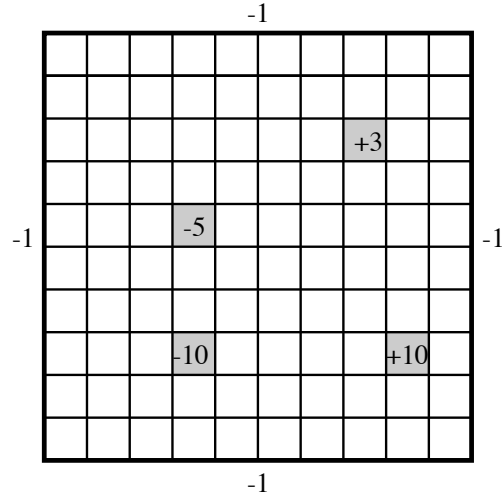

Figure 12.5: Grid world

```

83     """returns the (reward, state) in the direction a.
84     This is where the agent will end up if to goes in its
      intended_direction
85     (which it does with probability 0.7).
86     """
87     (x,y) = s
88     if a=='up':
89         return (0, (x,y+1)) if y+1 < self.y_dim else (-1, (x,y))
90     if a=='down':
91         return (0, (x,y-1)) if y > 0 else (-1, (x,y))
92     if a=='right':
93         return (0, (x+1,y)) if x+1 < self.x_dim else (-1, (x,y))
94     if a=='left':
95         return (0, (x-1,y)) if x > 0 else (-1, (x,y))
96
97     def result(self,s,a):
98         """return a dictionary of {(r,s):p} where p is the probability of
99         reward r, state s.
100        a state is an (x,y) pair
101        """
102        r0 = self.rewarding_states[s] if s in self.rewarding_states else 0
103        if s in self.fling_states:
104            return {(r0,(0,0)): 0.25, (r0,(self.x_dim-1,0)):0.25,
105                    (r0,(0,self.y_dim-1)):0.25,
106                    (r0,(self.x_dim-1,self.y_dim-1)):0.25}
107        dist = distribution({})
108        for a1 in self.actions:
109            (r1,s1) = self.intended_next(s,a1)
110            rs = (r1+r0, s1)
111            p = 0.7 if a1==a else 0.1

```

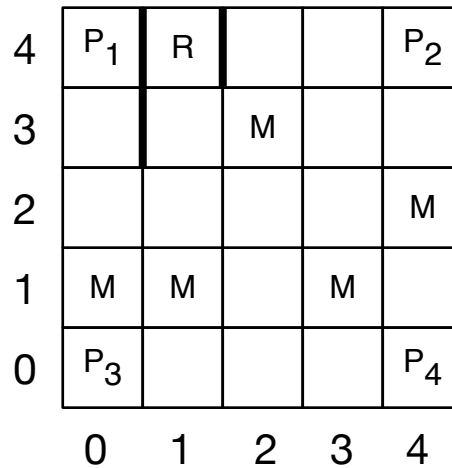

Figure 12.6: Monster game

```

110         dist.add_prob(rs,p)
111     return dist

```

### Monster Game

This is for the game depicted in Figure 13.1 (Example 13.2 of Poole and Mackworth [2023]).

```

_____ mdpExamples.py — (continued) _____
113 class Monster_game(ProblemDomain, GridDomain):
114
115     vwalls = [(0,3), (0,4), (1,4)] # vertical walls right of these locations
116     crash_reward = -1
117
118     prize_locs = [(0,0), (0,4), (4,0), (4,4)]
119     prize_appears_prob = 0.3
120     prize_reward = 10
121
122     monster_locs = [(0,1), (1,1), (2,3), (3,1), (4,2)]
123     monster_appears_prob = 0.4
124     monster_reward_when_damaged = -10
125     repair_stations = [(1,4)]
126
127     def __init__(self, discount=0.9):
128         x_dim = 5
129         y_dim = 5
130         # which damaged and prize to show
131         ProblemDomain.__init__(self,
132             "Monster Game",
133             [(x,y,damaged,prize)

```

```

134         for x in range(x_dim)
135             for y in range(y_dim)
136                 for damaged in [False,True]
137                     for prize in [None]+self.prize_locs, #states
138             ['up', 'down', 'right', 'left'], #actions
139             discount,
140             x_dim = x_dim, y_dim = y_dim,
141             offsets = {'right':(0.25,0), 'up':(0,0.25), 'left':(-0.25,0),
142                     'down':(0,-0.25)}
143         self.state = (2,2,False,None)
144
145     def intended_next(self,xy,a):
146         """returns the (reward, (x,y)) in the direction a.
147         This is where the agent will end up if to goes in its
148         intended_direction
149         (which it does with probability 0.7).
150         """
151         (x,y) = xy # original x-y position
152         if a=='up':
153             return (0, (x,y+1)) if y+1 < self.y_dim else
154                 (self.crash_reward, (x,y))
155         if a=='down':
156             return (0, (x,y-1)) if y > 0 else (self.crash_reward, (x,y))
157         if a=='right':
158             if (x,y) in self.vwalls or x+1==self.x_dim: # hit wall
159                 return (self.crash_reward, (x,y))
160             else:
161                 return (0, (x+1,y))
162         if a=='left':
163             if (x-1,y) in self.vwalls or x==0: # hit wall
164                 return (self.crash_reward, (x,y))
165             else:
166                 return (0, (x-1,y))
167
168     def result(self,s,a):
169         """return a dictionary of {(r,s):p} where p is the probability of
170         reward r, state s.
171         a state is an (x,y) pair
172         """
173         (x,y,damaged,prize) = s
174         dist = distribution({})
175         for a1 in self.actions: # possible results
176             mp = 0.7 if a1==a else 0.1
177             mr,(xn,yn) = self.intended_next((x,y),a1)
178             if (xn,yn) in self.monster_locs:
179                 if damaged:
180                     dist.add_prob((mr+self.monster_reward_when_damaged, (xn,yn,True,prize)),
181                                 mp*self.monster_appears_prob)
182                 dist.add_prob((mr, (xn,yn,True,prize)),
183                               mp*(1-self.monster_appears_prob))

```

```

178         else:
179             dist.add_prob((mr, (xn, yn, True, prize)),
180                          mp*self.monster_appears_prob)
181             dist.add_prob((mr, (xn, yn, False, prize)),
182                          mp*(1-self.monster_appears_prob))
183         elif (xn, yn) == prize:
184             dist.add_prob((mr+self.prize_reward, (xn, yn, damaged, None)),
185                          mp)
186         elif (xn, yn) in self.repair_stations:
187             dist.add_prob((mr, (xn, yn, False, prize)), mp)
188         else:
189             dist.add_prob((mr, (xn, yn, damaged, prize)), mp)
190     if prize is None:
191         res = distribution({})
192         for (r, (x2, y2, d, p2)), p in dist.items():
193             res.add_prob((r, (x2, y2, d, None)),
194                          p*(1-self.prize_appears_prob))
195         for pz in self.prize_locs:
196             res.add_prob((r, (x2, y2, d, pz)),
197                          p*self.prize_appears_prob/len(self.prize_locs))
198     return res
199 else:
200     return dist
201
202 def state2pos(self, state):
203     """When displaying as a grid, this specifies how the state is
204     mapped to (x,y) position.
205     The default is for domains where the (x,y) position is the state
206     """
207     (x, y, d, p) = state
208     return (x, y)
209
210 def pos2state(self, pos):
211     """When displaying as a grid, this specifies how the state is
212     mapped to (x,y) position.
213     """
214     (x, y) = pos
215     (xs, ys, damaged, prize) = self.state
216     return (x, y, damaged, prize)
217
218 def state2goal(self, state):
219     """the (x,y) position for the goal
220     """
221     (x, y, damaged, prize) = state
222     return prize
223
224 # To see value iterations:
225 # mg = Monster_game()
226 # mg.viGUI() # then run vi a few times
227 # to see other states, exit the GUI

```

```

221 # mg.state = (2,2,True,(4,4)) # or other damaged/prize states
222 # mg.viGUI()

```

### 12.2.2 Value Iteration

The following implements value iteration for Markov decision processes.

A  $Q$  function is represented as a dictionary so  $Q[s][a]$  is the value for doing action  $a$  in state  $s$ . The value function is represented as a dictionary so  $V[s]$  is the value of state  $s$ . Policy  $\pi$  is represented as a dictionary where  $\pi[s]$ , where  $s$  is a state, returns the the action.

Note that the following defines `vi` to be a method in `MDP`.

```

-----mdpProblem.py --- (continued) -----
124 def vi(self, n):
125     """carries out n iterations of value iteration, updating value
        function self.V
126     Returns a Q-function, value function, policy
127     """
128     self.display(3,f"calling vi({n})")
129     for i in range(n):
130         self.Q = {s: {a: self.R(s,a)
131                     +self.discount*sum(p1*self.V[s1]
132                                     for (s1,p1) in
133                                     self.P(s,a).items())
134                     for a in self.actions}
135                 for s in self.states}
136         self.V = {s: max(self.Q[s][a] for a in self.actions)
137                 for s in self.states}
138         self.pi = {s: argmaxd(self.Q[s])
139                  for s in self.states}
140     return self.Q, self.V, self.pi
141 MDP.vi = vi

```

The following shows how this can be used.

```

-----mdpExamples.py --- (continued) -----
224 ## Testing value iteration
225 # Try the following:
226 # pt = partyMDP(discount=0.9)
227 # pt.vi(1)
228 # pt.vi(100)
229 # partyMDP(discount=0.99).vi(100)
230 # partyMDP(discount=0.4).vi(100)
231
232 # gr = grid(discount=0.9)
233 # gr.viGUI()
234 # q,v,pi = gr.vi(100)
235 # q[(7,2)]

```

### 12.2.3 Value Iteration GUI for Grid Domains

A `GridDomain` is a domain where the states can be mapped into  $(x,y)$  positions, and the actions can be mapped into up-down-left-right. They are special because the `viGUI()` method to interact with them. It requires the following values/methods be defined:

- `self.x_dim` and `self.y_dim` define the dimensions of the grid (so the states are  $(x,y)$ , where  $0 \leq x < \text{self.x\_dim}$  and  $0 \leq y < \text{self.y\_dim}$ ).
- `self.state2pos(state)` gives the  $(x,y)$  position of state. The default is that that states are already  $(x,y)$  positions.
- `self.state2goal(state)` gives the  $(x,y)$  position of the goal in state. The default is `None`.
- `self.pos2state(pos)` where `pos` is an  $(x,y)$  pair, gives the state that is shown at position  $(x,y)$ . When the state contain more information than the  $(x,y)$  pair, the extra informmation is taken from `self.state`.
- `self.offsets[a]` defines where to display action `a`, as  $(x,y)$  offset for action `a` when displaying Q-values.

```

mdpGUI.py — GUI for value iteration in MDPs
11 import matplotlib.pyplot as plt
12 from matplotlib.widgets import Button, CheckButtons, TextBox
13 from mdpProblem import MDP
14
15 class GridDomain(object):
16
17     def viGUI(self):
18         plt.ion() # interactive
19         fig,self.ax = plt.subplots()
20         plt.subplots_adjust(bottom=0.2)
21         stepB = Button(plt.axes([0.8,0.05,0.1,0.075]), "step")
22         stepB.on_clicked(self.on_step)
23         resetB = Button(plt.axes([0.65,0.05,0.1,0.075]), "reset")
24         resetB.on_clicked(self.on_reset)
25         self.qcheck = CheckButtons(plt.axes([0.2,0.05,0.35,0.075]),
26                                     ["show Q-values","show policy"])
27         self.qcheck.on_clicked(self.show_vals)
28         self.font_box = TextBox(plt.axes([0.1,0.05,0.05,0.075]),"Font:",
29                                   textalignment="center")
30         self.font_box.on_submit(self.set_font_size)
31         self.font_box.set_val(str(plt.rcParams['font.size']))
32         self.show_vals(None)
33         plt.show()
34
35     def set_font_size(self, s):
36         plt.rcParams.update({'font.size': eval(s)})

```

```

36         plt.draw()
37
38     def show_vals(self, event):
39         self.ax.cla() # clear the axes
40
41         array = [[self.V[self.pos2state((x,y))] for x in range(self.x_dim)]
42                  for y in range(self.y_dim)]
43         self.ax.pcolormesh([x-0.5 for x in range(self.x_dim+1)],
44                             [y-0.5 for y in range(self.y_dim+1)],
45                             array, edgecolors='black', cmap='summer')
46
47         # for cmap see
48         # https://matplotlib.org/stable/tutorials/colors/colormaps.html
49     if self.qcheck.get_status()[1]: # "show policy"
50         for x in range(self.x_dim):
51             for y in range(self.y_dim):
52                 state = self.pos2state((x,y))
53                 maxv = max(self.Q[state][a] for a in self.actions)
54                 for a in self.actions:
55                     if self.Q[state][a] == maxv:
56                         # draw arrow in appropriate direction
57                         xoff, yoff = self.offsets[a]
58                         self.ax.arrow(x,y,xoff*2,yoff*2,
59                                         color='red', width=0.05, head_width=0.2,
60                                         length_includes_head=True)
61     if self.qcheck.get_status()[0]: # "show q-values"
62         self.show_q(event)
63     else:
64         self.show_v(event)
65         self.ax.set_xticks(range(self.x_dim))
66         self.ax.set_xticklabels(range(self.x_dim))
67         self.ax.set_yticks(range(self.y_dim))
68         self.ax.set_yticklabels(range(self.y_dim))
69         plt.draw()
70
71     def on_step(self, event):
72         self.step()
73         self.show_vals(event)
74
75     def step(self):
76         """The default step is one step of value iteration"""
77         self.vi(1)
78
79     def show_v(self, event):
80         """show values"""
81         for x in range(self.x_dim):
82             for y in range(self.y_dim):
83                 state = self.pos2state((x,y))
84                 self.ax.text(x,y,"{val:.2f}".format(val=self.V[state]), ha='center')
85
86     def show_q(self, event):

```

```

85     """show q-values"""
86     for x in range(self.x_dim):
87         for y in range(self.y_dim):
88             state = self.pos2state((x,y))
89             for a in self.actions:
90                 xoff, yoff = self.offsets[a]
91                 self.ax.text(x+xoff,y+yoff,
92                             "{val:.2f}".format(val=self.Q[state][a]),ha='center')
93
94     def on_reset(self,event):
95         self.V = {s:self.vinit for s in self.states}
96         self.Q = {s: {a: self.vinit for a in self.actions} for s in
97                   self.states}
98         self.show_vals(event)
99
100 # to use the GUI do some of:
101 # python -i mdpExamples.py
102 # MDPtiny(discount=0.9).viGUI()
103 # grid(discount=0.9).viGUI()
104 # Monster_game(discount=0.9).viGUI()

```

Figure 12.7 shows the user interface for the tiny domain, which can be obtained using

```
MDPtiny(discount=0.9).viGUI()
```

resizing it, checking “show q-values” and “show policy”, and clicking “step” a few times.

```

To run the demo in class do:
% python -i mdpExamples.py
MDPtiny(discount=0.9).viGUI()

```

Figure 12.8 shows the user interface for the grid domain, which can be obtained using

```
grid(discount=0.9).viGUI()
```

resizing it, checking “show q-values” and “show policy”, and clicking “step” a few times.

**Exercise 12.1** Computing  $q$  before  $v$  may seem like a waste of space because we don’t need to store  $q$  in order to compute value function or the policy. Change the algorithm so that it loops through the states and actions once per iteration, and only stores the value function and the policy. Note that to get the same results as before, you would need to make sure that you use the previous value of  $v$  in the computation not the current value of  $v$ . Does using the current value of  $v$  hurt the algorithm or make it better (in approaching the actual value function)?

## 12.2.4 Asynchronous Value Iteration

This implements asynchronous value iteration, storing  $Q$ .

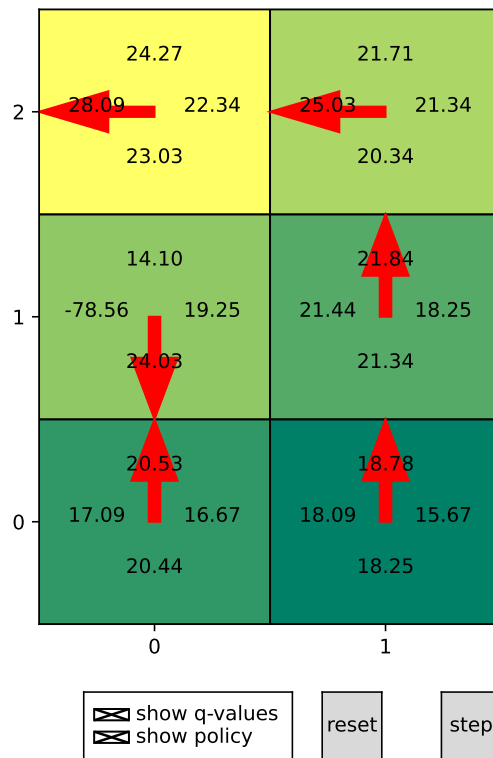

Figure 12.7: Interface for tiny example, after a number of steps. Each rectangle represents a state. In each rectangle are the 4 Q-values for the state. The leftmost number is the for the left action; the rightmost number is for the right action; the upper most is for the *upR* (up-risky) action and the lowest number is for the *upC* action. The arrow points to the action(s) with the maximum Q-value. Use `MDPtiny().viGUI()` after loading `mdpExamples.py`

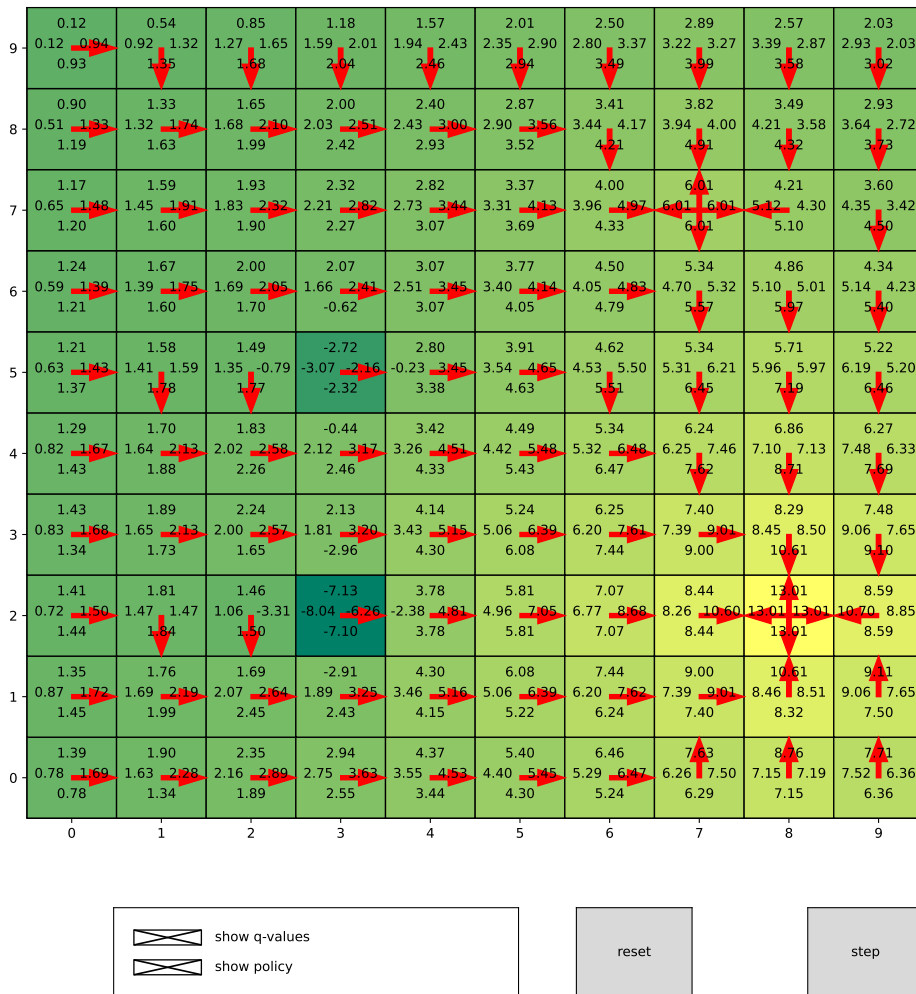

Figure 12.8: Interface for grid example, after a number of steps. Each rectangle represents a state. In each rectangle are the 4 Q-values for the state. The leftmost number is the for the left action; the rightmost number is for the right action; the upper most is for the up action and the lowest number is for the down action. The arrow points to the action(s) with the maximum Q-value. From `grid(discount=0.9).viGUI()`

A  $Q$  function is represented so  $q[s][a]$  is the value for doing action with index  $a$  state with index  $s$ .

Note that the following defines `avi` to be a method of MDP.

```

_____mdpProblem.py — (continued)_____
143 def avi(self,n):
144     states = list(self.states)
145     actions = list(self.actions)
146     for i in range(n):
147         s = random.choice(states)
148         a = random.choice(actions)
149         self.Q[s][a] = (self.R(s,a) + self.discount *
150                        sum(p1 * max(self.Q[s1][a1]
151                                   for a1 in self.actions)
152                             for (s1,p1) in self.P(s,a).items()))
153     return self.Q
154
155 MDP.avi = avi

```

The following shows how `avi` can be used.

```

_____mdpExamples.py — (continued)_____
238 ## Testing asynchronous value iteration
239 # Try the following:
240 # pt = partyMDP(discount=0.9)
241 # pt.avi(10)
242 # pt.vi(1000)
243
244 # gr = grid(discount=0.9)
245 # q = gr.avi(100000)
246 # q[(7,2)]
247
248 def test_MDP(mdp, discount=0.9, eps=0.01):
249     """tests vi and avi give the same answer for a MDP class mdp
250     """
251     mdp1 = mdp(discount=discount)
252     q1,v1,pi1 = mdp1.vi(100)
253     mdp2 = mdp(discount=discount)
254     q2 = mdp2.avi(1000)
255     same = all(abs(q1[s][a]-q2[s][a]) < eps
256               for s in mdp1.states
257               for a in mdp1.actions)
258     assert same, "vi and avi are different:\n{q1}\n{q2}"
259     print(f"passed unit test. vi and avi gave same result for {mdp1.title}")
260
261 if __name__ == "__main__":
262     test_MDP(partyMDP)

```

**Exercise 12.2** Implement value iteration that stores the  $V$ -values rather than the  $Q$ -values. Does it work better than storing  $Q$ ? (What might “better” mean?)

**Exercise 12.3** In asynchronous value iteration, try a number of different ways to choose the states and actions to update (e.g., sweeping through the state-action pairs, choosing them at random). Note that the best way may be to determine which states have had their Q-values change the most, and then update the previous ones, but that is not so straightforward to implement, because you need to find those previous states.

## Reinforcement Learning

### 13.1 Representing Agents and Environments

The reinforcement learning agents and environments are instances of the general agent architecture of Section 2.1, where the percepts are reward–state pairs. The *state* is the world state; this is the fully observable assumption. In particular:

- An agent implements the method `select_action` that takes the reward (and environment state and returns the next action (and updates the state of the agent).
- An environment implements the method `do` that takes the action and returns a pair of the reward and the resulting environment state.

These are chained together to simulate the system.

This follows the architecture of Section 2.1; here the percept is the state. The simulation starts by calling the agent method `initial_action(state)`, which is generally to remember the state and return a random action.

#### 13.1.1 Environments

The environments have names for the roles of agents participating. In this chapter, where we assume a single agent, this is used as the name of the environment.

```
_____rlProblem.py — Representations for Reinforcement Learning _____  
11 import random  
12 import math  
13 from display import Displayable
```

```

14 from agents import Agent, Environment
15 from utilities import select_from_dist, argmaxe, argmaxd, flip
16
17 class RL_env(Environment):
18     def __init__(self, name, actions, state):
19         """creates an environment given name, list of actions, and initial
20            state"""
21         self.name = name      # the role for an agent
22         self.actions = actions # list of all actions
23         self.state = state    # initial state
24         self.reward = None    # last reward
25
26     # must implement do(action)->(reward,state)

```

### 13.1.2 Agents

```

r1Problem.py — (continued)
27 class RL_agent(Agent):
28     """An RL_Agent
29     has percepts (s, r) for some state s and real reward r
30     """
31     def __init__(self, actions):
32         self.actions = actions
33
34     def initial_action(self, env_state):
35         """return the initial action, and remember the state and action
36         Act randomly initially
37         Could be overridden to initialize data structures (as the agent now
38            knows about one state)
39         """
40         self.state = env_state
41         self.action = random.choice(self.actions)
42         return self.action
43
44     def select_action(self, reward, state):
45         """
46         Select the action given the reward and next state
47         Remember the action in self.action
48         This implements "Act randomly" and should be overridden!
49         """
50         self.reward = reward
51         self.action = random.choice(self.actions)
52         return self.action
53
54     def v(self, state):
55         """v needed for GUI; an agent must also implement q()"""
56         return max(self.q(state,a) for a in self.actions)

```

### 13.1.3 Simulating an Environment-Agent Interaction

The interaction between the agents and the environment is mediated by a simulator that calls each in turn. `Simulate` below is similar to `Simulate` of Section 2.1, except it is initialized by `agent.initial_action(state)`.

```

_____rlProblem.py — (continued)_____
57 import matplotlib.pyplot as plt
58
59 class Simulate(Displayable):
60     """simulate the interaction between the agent and the environment
61     for n time steps.
62     Returns a pair of the agent state and the environment state.
63     """
64     def __init__(self, agent, environment):
65         self.agent = agent
66         self.env = environment
67         self.reward_history = [] # for plotting
68         self.step = 0
69         self.sum_rewards = 0
70
71     def start(self):
72         self.action = self.agent.initial_action(self.env.state)
73         return self
74
75     def go(self, n):
76         for i in range(n):
77             self.step += 1
78             (reward,state) = self.env.do(self.action)
79             self.display(2,f"step={self.step} reward={reward},
              state={state}")
80             self.sum_rewards += reward
81             self.reward_history.append(reward)
82             self.action = self.agent.select_action(reward,state)
83             self.display(2,f"  action={self.action}")
84         return self

```

The following plots the sum of rewards as a function of the step in a simulation.

```

_____rlProblem.py — (continued)_____
86 def plot(self, label=None, step_size=None, xscale='linear'):
87     """
88     plots the rewards history in the simulation
89     label is the label for the plot
90     step_size is the number of steps between each point plotted
91     xscale is 'log' or 'linear'
92
93     returns sum of rewards
94     """

```

```

95     if step_size is None: #for long simulations (> 999), only plot some
96         points
97         step_size = max(1,len(self.reward_history)//500)
98     if label is None:
99         label = self.agent.method
100    plt.ion()
101    plt.xscale(xscale)
102    plt.xlabel("step")
103    plt.ylabel("Sum of rewards")
104    sum_history, sum_rewards = acc_rews(self.reward_history, step_size)
105    plt.plot(range(0,len(self.reward_history),step_size), sum_history,
106             label=label)
107    plt.legend()
108    plt.draw()
109    return sum_rewards
110
111 def acc_rews(rews,step_size):
112     """returns the rolling sum of the values, sampled each step_size, and
113     the sum
114     """
115     acc = []
116     sumr = 0; i=0
117     for e in rews:
118         sumr += e
119         i += 1
120         if (i%step_size == 0): acc.append(sumr)
121     return acc, sumr

```

### 13.1.4 Party Environment

Here is the definition of the simple 2-state, 2-action decision about whether to party or relax (Example 12.29 in Poole and Mackworth [2023]). (Compare to the MDP representation of page 290)

```

_____rlExamples.py — Some example reinforcement learning environments_____
11 from rlProblem import RL_env
12 class Party_env(RL_env):
13     def __init__(self):
14         RL_env.__init__(self, "Party Decision", ["party", "relax"],
15                        "healthy")
16
17     def do(self, action):
18         """updates the state based on the agent doing action.
19         returns reward,state
20         """
21         if self.state=="healthy":
22             if action=="party":
23                 self.state = "healthy" if flip(0.7) else "sick"
24                 self.reward = 10
25             else: # action=="relax"

```

```

25         self.state = "healthy" if flip(0.95) else "sick"
26         self.reward = 7
27     else: # self.state=="sick"
28         if action=="party":
29             self.state = "healthy" if flip(0.1) else "sick"
30             self.reward = 2
31         else:
32             self.state = "healthy" if flip(0.5) else "sick"
33             self.reward = 0
34     return self.reward, self.state

```

### 13.1.5 Environment from a Problem Domain

`Env_fom_ProblemDomain` takes a `ProblemDomain` (page 291) and constructs an environment that can be used for reinforcement learners.

As explained in Section 12.2.1, the representation of an MDP does not contain enough information to simulate a system, because it loses any dependency between the rewards and the resulting state (e.g., hitting the wall and having a negative reward may be correlated), and only represents the expected value of rewards, not how they are distributed. The `ProblemDomain` class defines the `result` method to map states and actions into distributions over (reward, state) pairs.

```

----- rlProblem.py --- (continued) -----
120
121 class Env_from_ProblemDomain(RL_env):
122     def __init__(self, prob_dom):
123         RL_env.__init__(self, prob_dom.title, prob_dom.actions,
124                         prob_dom.state)
125         self.problem_domain = prob_dom
126         self.state = prob_dom.state
127         self.x_dim = prob_dom.x_dim
128         self.y_dim = prob_dom.y_dim
129         self.offsets = prob_dom.offsets
130         self.state2pos = self.problem_domain.state2pos
131         self.state2goal = self.problem_domain.state2goal
132         self.pos2state = self.problem_domain.pos2state
133
134     def do(self, action):
135         """updates the state based on the agent doing action.
136         returns state,reward
137         """
138         (self.reward, self.state) =
139             select_from_dist(self.problem_domain.result(self.state, action))
140         self.problem_domain.state = self.state
141         self.display(2,f"do({action} -> ({self.reward}, {self.state}))")
142         return (self.reward,self.state)

```

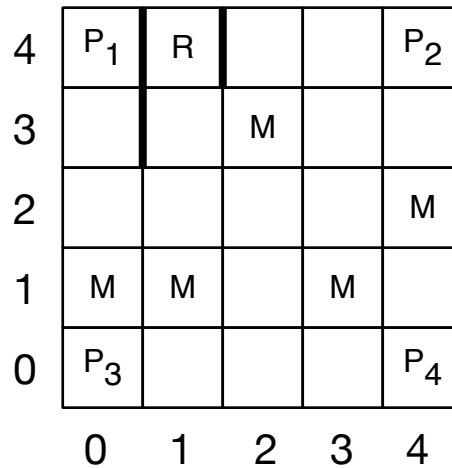

Figure 13.1: Monster game

### 13.1.6 Monster Game Environment

This is for the game depicted in Figure 13.1 (Example 13.2 of Poole and Mackworth [2023]). This is an alternative representation to that of Section 12.2.1, which defined the distribution over reward-state pairs. This directly builds a simulator, which might be easier to understand or adapt to new environments.

```

_____rlExamples.py — (continued)_____
36 import random
37 from utilities import flip
38 from rlProblem import RL_env
39
40 class Monster_game_env(RL_env):
41     x_dim = 5
42     y_dim = 5
43
44     vwalls = [(0,3), (0,4), (1,4)] # vertical walls right of these locations
45     hwalls = [] # not implemented
46     crashed_reward = -1
47
48     prize_locs = [(0,0), (0,4), (4,0), (4,4)]
49     prize_appears_prob = 0.3
50     prize_reward = 10
51
52     monster_locs = [(0,1), (1,1), (2,3), (3,1), (4,2)]
53     monster_appears_prob = 0.4
54     monster_reward_when_damaged = -10
55     repair_stations = [(1,4)]
56
57     actions = ["up", "down", "left", "right"]

```

```

58
59 def __init__(self):
60     # State:
61     self.x = 2
62     self.y = 2
63     self.damaged = False
64     self.prize = None
65     # Statistics
66     self.number_steps = 0
67     self.accumulated_rewards = 0 # sum of rewards received
68     self.min_accumulated_rewards = 0
69     self.min_step = 0
70     self.zero_crossing = 0
71     RL_env.__init__(self, "Monster Game", self.actions, (self.x,
72         self.y, self.damaged, self.prize))
73     self.display(2,"","Step","Tot Rew","Ave Rew",sep="\t")
74
75 def do(self,action):
76     """updates the state based on the agent doing action.
77     returns reward,state
78     """
79     assert action in self.actions, f"Monster game, unknown action:
80         {action}"
81     self.reward = 0.0
82     # A prize can appear:
83     if self.prize is None and flip(self.prize_appears_prob):
84         self.prize = random.choice(self.prize_locs)
85     # Actions can be noisy
86     if flip(0.4):
87         actual_direction = random.choice(self.actions)
88     else:
89         actual_direction = action
90     # Modeling the actions given the actual direction
91     if actual_direction == "right":
92         if self.x==self.x_dim-1 or (self.x,self.y) in self.vwalls:
93             self.reward += self.crashed_reward
94         else:
95             self.x += 1
96     elif actual_direction == "left":
97         if self.x==0 or (self.x-1,self.y) in self.vwalls:
98             self.reward += self.crashed_reward
99         else:
100             self.x += -1
101     elif actual_direction == "up":
102         if self.y==self.y_dim-1:
103             self.reward += self.crashed_reward
104         else:
105             self.y += 1
106     elif actual_direction == "down":
107         if self.y==0:

```

```

106         self.reward += self.crashed_reward
107     else:
108         self.y += -1
109 else:
110     raise RuntimeError(f"unknown_direction: {actual_direction}")
111
112 # Monsters
113 if (self.x,self.y) in self.monster_locs and
114     flip(self.monster_appears_prob):
115     if self.damaged:
116         self.reward += self.monster_reward_when_damaged
117     else:
118         self.damaged = True
119 if (self.x,self.y) in self.repair_stations:
120     self.damaged = False
121
122 # Prizes
123 if (self.x,self.y) == self.prize:
124     self.reward += self.prize_reward
125     self.prize = None
126
127 # Statistics
128 self.number_steps += 1
129 self.accumulated_rewards += self.reward
130 if self.accumulated_rewards < self.min_accumulated_rewards:
131     self.min_accumulated_rewards = self.accumulated_rewards
132     self.min_step = self.number_steps
133 if self.accumulated_rewards>0 and
134     self.reward>self.accumulated_rewards:
135     self.zero_crossing = self.number_steps
136 self.display(2, "", self.number_steps, self.accumulated_rewards,
137             self.accumulated_rewards/self.number_steps, sep="\t")

```

The following methods are used by the GUI (Section 13.7, page 334) so that the states can be shown.

```

_____rlExamples.py — (continued)_____
139 ### For GUI
140 def state2pos(self, state):
141     """the (x,y) position for the state
142     """
143     (x, y, damaged, prize) = state
144     return (x,y)
145
146 def state2goal(self, state):
147     """the (x,y) position for the goal
148     """
149     (x, y, damaged, prize) = state
150     return prize

```

```

151
152     def pos2state(self, pos):
153         """the state corresponding to the (x,y) position.
154         The damages and prize are not shown in the GUI
155         """
156         (x,y) = pos
157         return (x, y, self.damaged, self.prize)

```

## 13.2 Q Learning

To run the Q-learning demo, in folder "aipython", load "rlQLearner.py", and copy and paste the example queries at the bottom of that file.

```

-----rlQLearner.py — Q Learning-----
11 import random
12 import math
13 from display import Displayable
14 from utilities import argmaxe, argmaxd, flip
15 from rlProblem import RL_agent, epsilon_greedy, ucb
16
17 class Q_learner(RL_agent):
18     """A Q-learning agent has
19     belief-state consisting of
20     state is the previous state (initialized by RL_agent
21     q is a {(state,action):value} dict
22     visits is a {(state,action):n} dict. n is how many times action was
23     done in state
24     acc_rewards is the accumulated reward
25     """
-----rlQLearner.py — (continued)-----
26     def __init__(self, role, actions, discount,
27                 exploration_strategy=epsilon_greedy, es_kwargs={},
28                 alpha_fun=lambda _:0.2,
29                 Qinit=0, method="Q_learner"):
30         """
31         role is the role of the agent (e.g., in a game)
32         actions is the set of actions the agent can do
33         discount is the discount factor
34         exploration_strategy is the exploration function, default
35         "epsilon_greedy"
36         es_kwargs is extra arguments of exploration_strategy
37         alpha_fun is a function that computes alpha from the number of
38         visits
39         Qinit is the initial q-value
40         method gives the method used to implement the role (for plotting)

```

```

39     """
40     RL_agent.__init__(self, actions)
41     self.role = role
42     self.discount = discount
43     self.exploration_strategy = exploration_strategy
44     self.es_kwargs = es_kwargs
45     self.alpha_fun = alpha_fun
46     self.Qinit = Qinit
47     self.method = method
48     self.acc_rewards = 0
49     self.Q = {}
50     self.visits = {}

```

The initial action is a random action. It remembers the state, and initializes the data structures.

```

----- rlQLearner.py --- (continued) -----
52     def initial_action(self, state):
53         """ Returns the initial action; selected at random
54         Initialize Data Structures
55         """
56         self.state = state
57         self.Q[state] = {act:self.Qinit for act in self.actions}
58         self.visits[state] = {act:0 for act in self.actions}
59         self.action = self.exploration_strategy(state, self.Q[state],
60                                             self.visits[state],**self.es_kwargs)
61         self.display(2, f"Initial State: {state} Action {self.action}")
62         self.display(2,"s\\ta\\tr\\ts\\tQ")
63         return self.action
64
65     def select_action(self, reward, next_state):
66         """give reward and next state, select next action to be carried
67         out"""
68         if next_state not in self.visits: # next state not seen before
69             self.Q[next_state] = {act:self.Qinit for act in self.actions}
70             self.visits[next_state] = {act:0 for act in self.actions}
71         self.visits[self.state][self.action] +=1
72         alpha = self.alpha_fun(self.visits[self.state][self.action])
73         self.Q[self.state][self.action] += alpha*(
74             reward
75             + self.discount * max(self.Q[next_state].values())
76             - self.Q[self.state][self.action])
77         self.display(2,self.state, self.action, reward, next_state,
78                 self.Q[self.state][self.action], sep='\\t')
79         self.action = self.exploration_strategy(next_state,
80                                             self.Q[next_state],
81                                             self.visits[next_state],**self.es_kwargs)
82         self.state = next_state
83         self.display(3,f"Agent {self.role} doing {self.action} in state
84                 {self.state}")
85         return self.action

```

The GUI assumes  $q(s, a)$  and  $v(s)$  functions:

```

-----rQLearner.py --- (continued) -----
84     def q(self, s, a):
85         if s in self.Q and a in self.Q[s]:
86             return self.Q[s][a]
87         else:
88             return self.Qinit
89
90     def v(self, s):
91         if s in self.Q:
92             return max(self.Q[s].values())
93         else:
94             return self.Qinit

```

**SARSA** is the same as Q-learning except in the action selection. SARSA changes 3 lines:

```

-----rQLearner.py --- (continued) -----
96 class SARSA(Q_learner):
97     def __init__(self, *args, **nargs):
98         Q_learner.__init__(self, *args, **nargs)
99         self.method = "SARSA"
100
101     def select_action(self, reward, next_state):
102         """give reward and next state, select next action to be carried
103            out"""
104         if next_state not in self.visits: # next state not seen before
105             self.Q[next_state] = {act:self.Qinit for act in self.actions}
106             self.visits[next_state] = {act:0 for act in self.actions}
107         self.visits[self.state][self.action] +=1
108         alpha = self.alpha_fun(self.visits[self.state][self.action])
109         next_action = self.exploration_strategy(next_state,
110             self.Q[next_state],
111             self.visits[next_state],**self.es_kwargs)
112         self.Q[self.state][self.action] += alpha*(
113             reward
114             + self.discount * self.Q[next_state][next_action]
115             - self.Q[self.state][self.action])
116         self.display(2,self.state, self.action, reward, next_state,
117             self.Q[self.state][self.action], sep='\t')
118         self.state = next_state
119         self.action = next_action
120         self.display(3,f"Agent {self.role} doing {self.action} in state
121             {self.state}")
122         return self.action

```

### 13.2.1 Exploration Strategies

Two explorations strategies are defined: epsilon-greedy and UCB.

In general an exploration strategy takes two arguments, and some optional arguments depending on the strategy.

- *State* is the state that action is chosen for
- *Qs* is a  $\{action : q\_value\}$  dictionary for the state
- *Vs* is a  $\{action : visits\}$  dictionary for the current state; where *visits* is the number of times that the action has been carried out in the current state.

```

r1Problem.py — (continued)
142 def epsilon_greedy(state, Qs, Vs={}, epsilon=0.2):
143     """select action given epsilon greedy
144     Qs is the {action:Q-value} dictionary for current state
145     Vs is ignored
146     epsilon is the probability of acting randomly
147     """
148     if flip(epsilon):
149         return random.choice(list(Qs.keys())) # act randomly
150     else:
151         return argmaxd(Qs) # pick an action with max Q
152
153 def ucb(state, Qs, Vs, c=1.4):
154     """select action given upper-confidence bound
155     Qs is the {action:Q-value} dictionary for current state
156     Vs is the {action:visits} dictionary for current state
157
158     0.01 is to prevent divide-by zero when Vs[a]==0
159     """
160     Ns = sum(Vs.values())
161     ucb1 = {a:Qs[a]+c*math.sqrt(Ns/(0.01+Vs[a]))
162            for a in Qs.keys()}
163     action = argmaxd(ucb1)
164     return action

```

**Exercise 13.1** Implement a soft-max action selection. Choose a temperature that works well for the domain. Explain how you picked this temperature. Compare the epsilon-greedy, soft-max and optimism in the face of uncertainty.

### 13.2.2 Testing Q-learning

The first tests are for the 2-action 2-state decision about whether to relax or party (Example 12.29 of Poole and Mackworth [2023]).

```

r1QLearner.py — (continued)
121 ##### TEST CASES #####
122 from rlProblem import Simulate,epsilon_greedy, ucb, Env_from_ProblemDomain
123 from rlExamples import Party_env, Monster_game_env
124 from rlQLearner import Q_learner

```

```

125 from mdpExamples import MDPTiny, partyMDP
126
127 def test_RL(learnerClass, mdp=partyMDP, env=Party_env(), discount=0.9,
128            eps=2, **kwargs):
129     """tests whether RL on env has the same (within eps) Q-values as vi on
130     mdp"""
131     mdp1 = mdp(discount=discount)
132     q1,v1,p1 = mdp1.vi(1000)
133     ag = learnerClass(env.name, env.actions, discount, **kwargs)
134     sim = Simulate(ag,env).start()
135     sim.go(100000)
136     same = all(abs(ag.q(s,a)-q1[s][a]) < eps
137                for s in mdp1.states
138                for a in mdp1.actions)
139     assert same, (f"""Unit test failed for {env.name},
140                  in {ag.method} Q="""+str({(s,a):ag.q(s,a) for s in mdp1.states for
141                  a in mdp1.actions})+f"""
142                  in vi Q={q1}""")
143     print(f"Unit test passed. For {env.name}, {ag.method} has same Q-value
144           as value iteration")
145 if __name__ == "__main__":
146     test_RL(Q_learner, alpha_fun=lambda k:10/(9+k))
147     # test_RL(SARSA) # should this pass? Why?
148
149 #env = Party_env()
150 env = Env_from_ProblemDomain(MDPTiny())
151 # Some RL agents with different parameters:
152 ag = Q_learner(env.name, env.actions, 0.7, method="eps (0.1) greedy" )
153 ag_ucb = Q_learner(env.name, env.actions, 0.7, exploration_strategy = ucb,
154                  es_kwargs={'c':0.1}, method="ucb")
155 ag_opt = Q_learner(env.name, env.actions, 0.7, Qinit=100,
156                  es_kwargs={'epsilon':0}, method="optimistic" )
157 ag_exp_m = Q_learner(env.name, env.actions, 0.7,
158                  es_kwargs={'epsilon':0.5}, method="more explore")
159 ag_greedy = Q_learner(env.name, env.actions, 0.1, Qinit=100, method="disc
160                   0.1")
161 sa = SARSA(env.name, env.actions, 0.9, method="SARSA")
162 suchb = SARSA(env.name, env.actions, 0.9, exploration_strategy = ucb,
163              es_kwargs={'c':1}, method="SARSA ucb")
164
165 sim_ag = Simulate(ag,env).start()
166
167 # sim_ag.go(1000)
168 # ag.Q # get the learned Q-values
169 # sim_ag.plot()
170 # sim_ucb = Simulate(ag_ucb,env).start(); sim_ucb.go(1000); sim_ucb.plot()
171 # Simulate(ag_opt,env).start().go(1000).plot()
172 # Simulate(ag_exp_m,env).start().go(1000).plot()
173 # Simulate(ag_greedy,env).start().go(1000).plot()
174 # Simulate(sa,env).start().go(1000).plot()

```

```

166 # Simulate(sucb,env).start().go(1000).plot()
167
168 from mdpExamples import MDptiny
169 envt = Env_from_ProblemDomain(MDptiny())
170 agt = Q_learner(envt.name, envt.actions, 0.8)
171 #Simulate(agt, envt).start().go(1000).plot()
172
173 ##### Monster Game #####
174 mon_env = Monster_game_env()
175 mag1 = Q_learner(mon_env.name, mon_env.actions, 0.9,
176                 method="alpha=0.2")
177 #Simulate(mag1,mon_env).start().go(100000).plot()
178 mag_ucb = Q_learner(mon_env.name, mon_env.actions, 0.9,
179                    exploration_strategy = ucb, es_kwargs={'c':0.1},
180                    method="UCB(0.1),alpha=0.2")
181 #Simulate(mag_ucb,mon_env).start().go(100000).plot()
182
183 mag2 = Q_learner(mon_env.name, mon_env.actions, 0.9,
184                 alpha_fun=lambda k:1/k,method="alpha=1/k")
185 #Simulate(mag2,mon_env).start().go(100000).plot()
186 mag3 = Q_learner(mon_env.name, mon_env.actions, 0.9,
187                 alpha_fun=lambda k:10/(9+k), method="alpha=10/(9+k)")
188 #Simulate(mag3,mon_env).start().go(100000).plot()
189
190 mag4 = Q_learner(mon_env.name, mon_env.actions, 0.9,
191                 alpha_fun=lambda k:10/(9+k),
192                 exploration_strategy = ucb, es_kwargs={'c':0.1},
193                 method="ucb & alpha=10/(9+k)")
194 #Simulate(mag4,mon_env).start().go(100000).plot()

```

### 13.3 Q-learning with Experience Replay

A bounded buffer remembers values up to size `buffer_size`. Once it is full, all old experiences have the same chance of being in the buffer.

```

_____rlQExperienceReplay.py — Q-Learner with Experience Replay_____
11 from rlQLearner import Q_learner
12 from utilities import flip
13 import random
14
15 class BoundedBuffer(object):
16     def __init__(self, buffer_size=1000):
17         self.buffer_size = buffer_size
18         self.buffer = [0]*buffer_size
19         self.number_added = 0
20
21     def add(self,experience):
22         if self.number_added < self.buffer_size:
23             self.buffer[self.number_added] = experience

```

```

24     else:
25         if flip(self.buffer_size/self.number_added):
26             position = random.randrange(self.buffer_size)
27             self.buffer[position] = experience
28         self.number_added += 1
29
30     def get(self):
31         return self.buffer[random.randrange(min(self.number_added,
32         self.buffer_size))]

```

A Q\_ER\_Learner does Q-learning with experience replay. It only uses action replay after burn\_in number of steps.

```

_____rlQExperienceReplay.py — (continued)_____
33 class Q_ER_learner(Q_learner):
34     def __init__(self, role, actions, discount,
35                 max_buffer_size=10000,
36                 num_updates_per_action=5, burn_in=1000,
37                 method="Q_ER_learner", **q_kwargs):
38         """Q-learner with experience replay
39         role is the role of the agent (e.g., in a game)
40         actions is the set of actions the agent can do
41         discount is the discount factor
42         max_buffer_size is the maximum number of past experiences that is
43         remembered
44         burn_in is the number of steps before using old experiences
45         num_updates_per_action is the number of q-updates for past
46         experiences per action
47         q_kwargs are any extra parameters for Q_learner
48         """
49         Q_learner.__init__(self, role, actions, discount, method=method,
50                             **q_kwargs)
51         self.experience_buffer = BoundedBuffer(max_buffer_size)
52         self.num_updates_per_action = num_updates_per_action
53         self.burn_in = burn_in
54
55     def select_action(self, reward, next_state):
56         """give reward and new state, select next action to be carried
57         out"""
58         self.experience_buffer.add((self.state,self.action,reward,next_state))
59         #remember experience
60         if next_state not in self.Q: # Q and visits are defined on the same
61         states
62             self.Q[next_state] = {act:self.Qinit for act in self.actions}
63             self.visits[next_state] = {act:0 for act in self.actions}
64         self.visits[self.state][self.action] +=1
65         alpha = self.alpha_fun(self.visits[self.state][self.action])
66         self.Q[self.state][self.action] += alpha*(
67             reward
68             + self.discount * max(self.Q[next_state].values())
69             - self.Q[self.state][self.action])

```

```

64     self.display(2,self.state, self.action, reward, next_state,
65                 self.Q[self.state][self.action], sep='\t')
66     self.state = next_state
67     # do some updates from experience buffer
68     if self.experience_buffer.number_added > self.burn_in:
69         for i in range(self.num_updates_per_action):
70             (s,a,r,ns) = self.experience_buffer.get()
71             self.visits[s][a] +=1 # is this correct?
72             alpha = self.alpha_fun(self.visits[s][a])
73             self.Q[s][a] += alpha * (r +
74                                     self.discount* max(self.Q[ns][na]
75                                                         for na in self.actions)
76                                     -self.Q[s][a] )
77     ### CHOOSE NEXT ACTION ###
78     self.action = self.exploration_strategy(next_state,
79                                             self.Q[next_state],
80                                             self.visits[next_state],**self.es_kwargs)
81     self.display(3,f"Agent {self.role} doing {self.action} in state
82                 {self.state}")
83     return self.action

```

rlQExperienceReplay.py — (continued)

```

83 from rlProblem import Simulate
84 from rlExamples import Monster_game_env
85 from rlQLearner import mag1, mag2, mag3
86
87 mon_env = Monster_game_env()
88 mag1ar = Q_ER_learner(mon_env.name, mon_env.actions,0.9,method="Q_ER")
89 # Simulate(mag1ar,mon_env).start().go(100000).plot()
90
91 mag3ar = Q_ER_learner(mon_env.name, mon_env.actions, 0.9, alpha_fun=lambda
92                       k:10/(9+k),meth="Q_ER alpha=10/(9+k)")
93 # Simulate(mag3ar,mon_env).start().go(100000).plot()
94
95 from rlQLearner import test_RL
96 if __name__ == "__main__":
97     test_RL(Q_ER_learner)

```

## 13.4 Stochastic Policy Learning Agent

The following agent is like a Q-learning agent but maintains a stochastic policy. The policy is represented as unnormalized counts for each action in a state (like a Dirichlet distribution). This is the code described in Section 14.7.2 and Figure 14.10 of Poole and Mackworth [2023].

rlStochasticPolicy.py — Simulations of agents learning

```

11 from display import Displayable
12 import utilities # argmaxall for (element,value) pairs

```

```

13 import matplotlib.pyplot as plt
14 import random
15 from rlQLearner import Q_learner
16
17 class StochasticPIAgent(Q_learner):
18     """This agent maintains the Q-function for each state.
19     Chooses the best action using empirical distribution over actions
20     """
21     def __init__(self, role, actions, discount=0, pi_init=1,
22                 method="Stochastic Q_learner", **nargs):
23         """
24         role is the role of the agent (e.g., in a game)
25         actions is the set of actions the agent can do.
26         discount is the discount factor (0 is appropriate if there is a
27             single state)
28         pi_init gives the prior counts (Dirichlet prior) for the policy
29             (must be >0)
30         """
31         #self.max_display_level = 3
32         Q_learner.__init__(self, role, actions, discount,
33                             exploration_strategy=self.action_from_stochastic_policy,
34                             method=method, **nargs)
35         self.pi_init = pi_init
36         self.pi = {}
37
38     def initial_action(self, state):
39         """ update policy pi then do initial action from Q_learner
40         """
41         self.pi[state] = {act:self.pi_init for act in self.actions}
42         return Q_learner.initial_action(self, state)
43
44     def action_from_stochastic_policy(self, next_state, qs, vs):
45         a_best = utilities.argmaxd(self.Q[self.state])
46         self.pi[self.state][a_best] +=1
47         if next_state not in self.pi:
48             self.pi[next_state] = {act:self.pi_init for act in
49                 self.actions}
50         return select_from_dist(self.pi[next_state])
51
52     def normalize(dist):
53         """dict is a {value:number} dictionary, where the numbers are all
54         non-negative
55         returns dict where the numbers sum to one
56         """
57         tot = sum(dist.values())
58         return {var:val/tot for (var,val) in dist.items()}
59
60     def select_from_dist(dist):
61         rand = random.random()
62         for (act,prob) in normalize(dist).items():

```

```

58     rand -= prob
59     if rand < 0:
60         return act

```

The agent can be tested on the reinforcement learning benchmarks:

```

r1StochasticPolicy.py — (continued)
62 ##### Testing on RL benchmarks #####
63 from rlProblem import Simulate
64 import rlExamples
65 mon_env = rlExamples.Monster_game_env()
66 magspi = StochasticPIAgent(mon_env.name, mon_env.actions, 0.9)
67 #Simulate(magspi, mon_env).start().go(100000).plot()
68 magspi10 = StochasticPIAgent(mon_env.name, mon_env.actions, 0.9,
69     alpha_fun=lambda k: 10/(9+k), method="stoch 10/(9+k)")
70 #Simulate(magspi10, mon_env).start().go(100000).plot()
71
72 from rlQLearner import test_RL
73 if __name__ == "__main__":
74     test_RL(StochasticPIAgent, alpha_fun=lambda k: 10/(9+k))

```

**Exercise 13.2** Test some other ways to determine the probabilities for the stochastic policy in `StochasticPIAgent`. (It currently can be seen as using a Dirichlet where the probability represents the proportion of times each action is best plus pseudo-counts).

Replace `self.pi[self.state][a_best] += 1` with something like `self.pi[self.state][a_best] *= c` for some  $c > 1$ . E.g.,  $c = 1.1$  so it chooses that action 10% more, independently of the number of times tried. (Try to change the code as little as possible; make it so that either the original or different values of  $c$  can be run without changing your code. Warning: watch out for overflow.)

- Try for multiple  $c$ ; which one works best for the Monster game?
- Suggest an alternative way to update the probabilities in the policy (e.g., adding  $\delta$  to policy that is then normalized or some other methods). How well does it work?

## 13.5 Model-based Reinforcement Learner

To run the demo, in folder “aipython”, load “`r1ModelLearner.py`”, and copy and paste the example queries at the bottom of that file. This assumes Python 3.

A model-based reinforcement learner builds a Markov decision process model of the domain, simultaneously learns the model and plans with that model.

The model-based reinforcement learner used the following data structures:

- $Q[s][a]$  is dictionary that, given state  $s$  and action  $a$  returns the  $Q$ -value, the estimate of the future (discounted) value of being in state  $s$  and doing action  $a$ .

- $R[s][a]$  is dictionary that, given a  $(s, a)$  state  $s$  and action  $a$  is the average reward received from doing  $a$  in state  $s$ .
- $T[s][a][s']$  is dictionary that, given states  $s$  and  $s'$  and action  $a$  returns the number of times  $a$  was done in state  $s$  and the result was state  $s'$ . Note that  $s'$  is only a key if it has been the result of doing  $a$  in  $s$ ; there are no 0 counts recorded.
- $visits[s][a]$  is dictionary that, given state  $s$  and action  $a$  returns the number of times action  $a$  was carried out in state  $s$ . This is the  $C$  of Figure 13.6 of Poole and Mackworth [2023].

Note that  $visits[s][a] = \sum_{s'} T[s][a][s']$  but is stored separately to keep the code more readable.

The main difference to Figure 13.6 of Poole and Mackworth [2023] is the code below does a fixed number of asynchronous value iteration updates per step.

```

_____rlModelLearner.py — Model-based Reinforcement Learner _____
11 import random
12 from rlProblem import RL_agent, Simulate, epsilon_greedy, ucb
13 from display import Displayable
14 from utilities import argmaxe, flip
15
16 class Model_based_reinforcement_learner(RL_agent):
17     """A Model-based reinforcement learner
18     """
19
20     def __init__(self, role, actions, discount,
21                 exploration_strategy=epsilon_greedy, es_kwargs={},
22                 Qinit=0,
23                 updates_per_step=10, method="MBR_learner"):
24         """role is the role of the agent (e.g., in a game)
25         actions is the list of actions the agent can do
26         discount is the discount factor
27         explore is the proportion of time the agent will explore
28         Qinit is the initial value of the Q's
29         updates_per_step is the number of AVI updates per action
30         label is the label for plotting
31         """
32         RL_agent.__init__(self, actions)
33         self.role = role
34         self.actions = actions
35         self.discount = discount
36         self.exploration_strategy = exploration_strategy
37         self.es_kwargs = es_kwargs
38         self.Qinit = Qinit
39         self.updates_per_step = updates_per_step
40         self.method = method

```

```

rModelLearner.py — (continued)
42 def initial_action(self, state):
43     """ Returns the initial action; selected at random
44     Initialize Data Structures
45
46     """
47     self.action = RL_agent.initial_action(self, state)
48     self.T = {self.state: {a: {} for a in self.actions}}
49     self.visits = {self.state: {a: 0 for a in self.actions}}
50     self.Q = {self.state: {a: self.Qinit for a in self.actions}}
51     self.R = {self.state: {a: 0 for a in self.actions}}
52     self.states_list = [self.state] # list of states encountered
53     self.display(2, f"Initial State: {state} Action {self.action}")
54     self.display(2, "s\ta\tr\ts'\tQ")
55     return self.action

rModelLearner.py — (continued)
57 def select_action(self, reward, next_state):
58     """do num_steps of interaction with the environment
59     for each action, do updates_per_step iterations of asynchronous
60     value iteration
61     """
62     if next_state not in self.visits: # has not been encountered before
63         self.states_list.append(next_state)
64         self.visits[next_state] = {a:0 for a in self.actions}
65         self.T[next_state] = {a:{} for a in self.actions}
66         self.Q[next_state] = {a:self.Qinit for a in self.actions}
67         self.R[next_state] = {a:0 for a in self.actions}
68     if next_state in self.T[self.state][self.action]:
69         self.T[self.state][self.action][next_state] += 1
70     else:
71         self.T[self.state][self.action][next_state] = 1
72     self.visits[self.state][self.action] += 1
73     self.R[self.state][self.action] +=
74         (reward-self.R[self.state][self.action])/self.visits[self.state][self.action]
75     st,act = self.state,self.action #initial state-action pair for AVI
76     for update in range(self.updates_per_step):
77         self.Q[st][act] = self.R[st][act]+self.discount*(
78             sum(self.T[st][act][nst]/self.visits[st][act]*self.v(nst)
79                 for nst in self.T[st][act].keys()))
80         st = random.choice(self.states_list)
81         act = random.choice(self.actions)
82     self.state = next_state
83     self.action = self.exploration_strategy(next_state,
84         self.Q[next_state],
85         self.visits[next_state],**self.es_kwargs)
86     return self.action

def q(self, state, action):
    if state in self.Q and action in self.Q[state]:

```

```

87         return self.Q[state][action]
88     else:
89         return self.Qinit

```

```

-----r1ModelLearner.py --- (continued) -----
91 from rlExamples import Monster_game_env
92 mon_env = Monster_game_env()
93 mb11 = Model_based_reinforcement_learner(mon_env.name, mon_env.actions,
94     0.9, updates_per_step=1, method="model-based(1)")
95 # Simulate(mb11,mon_env).start().go(100000).plot()
96 mb110 = Model_based_reinforcement_learner(mon_env.name, mon_env.actions,
97     0.9, updates_per_step=10,method="model-based(10)")
98 # Simulate(mb110,mon_env).start().go(100000).plot()
99
100
101 from rlGUI import rlGUI
102 #gui = rlGUI(mon_env, mb11)
103
104
105 from rlQLearner import test_RL
106 if __name__ == "__main__":
107     test_RL(Model_based_reinforcement_learner)

```

**Exercise 13.3** If there was only one update per step, the algorithm can be made simpler and use less space. Explain how. Does it make it more efficient? Is it worthwhile having more than one update per step for the games implemented here?

**Exercise 13.4** It is possible to implement the model-based reinforcement learner by replacing  $Q$ ,  $R$ ,  $T$ ,  $visits$ ,  $res\_states$  with a single dictionary that, given a state and action returns a tuple corresponding to these data structures. Does this make the algorithm easier to understand? Does this make the algorithm more efficient?

**Exercise 13.5** If the states and the actions were mapped into integers, the dictionaries could be implemented perhaps more efficiently as arrays. How does the code need to change?. Implement this for the monster game. Is it more efficient?

**Exercise 13.6** In `random_choice` in the updates of `select_action`, all state-action pairs have the same chance of being chosen. Does selecting state-action pairs proportionally to the number of times visited work better than what is implemented? Provide evidence for your answer.

## 13.6 Reinforcement Learning with Features

To run the demo, in folder "aipython", load "r1Features.py", and copy and paste the example queries at the bottom of that file. This assumes Python 3.

### 13.6.1 Representing Features

A feature is a function from state and action. To construct the features for a domain, we construct a function that takes a state and an action and returns the list of all feature values for that state and action. This feature set is redesigned for each problem.

`party_features3` and `party_features4` return lists of feature values for the party decision. `party_features4` has one extra feature.

```

rGameFeature.py — Feature-based Reinforcement Learner
11 from rlExamples import Monster_game_env
12 from rlProblem import RL_env
13
14 def party_features3(state,action):
15     return [1, state=="sick", action=="party"]
16
17 def party_features4(state,action):
18     return [1, state=="sick", action=="party", state=="sick" and
            action=="party"]

```

**Exercise 13.7** With `party_features3` what policies can be discovered? Suppose one action is optimal for one state; what happens in other states.

The `monster_features` defines the vector of features values for the given state and action.

```

rGameFeature.py — (continued)
20 def monster_features(state,action):
21     """returns the list of feature values for the state-action pair
22     """
23     assert action in Monster_game_env.actions, f"Monster game, unknown
        action: {action}"
24     (x,y,d,p) = state
25     # f1: would go to a monster
26     f1 = monster_ahead(x,y,action)
27     # f2: would crash into wall
28     f2 = wall_ahead(x,y,action)
29     # f3: action is towards a prize
30     f3 = towards_prize(x,y,action,p)
31     # f4: damaged and action is toward repair station
32     f4 = towards_repair(x,y,action) if d else 0
33     # f5: damaged and towards monster
34     f5 = 1 if d and f1 else 0
35     # f6: damaged
36     f6 = 1 if d else 0
37     # f7: not damaged
38     f7 = 1-f6
39     # f8: damaged and prize ahead
40     f8 = 1 if d and f3 else 0
41     # f9: not damaged and prize ahead
42     f9 = 1 if not d and f3 else 0

```

```

43 features = [1,f1,f2,f3,f4,f5,f6,f7,f8,f9]
44 # the next 20 features are for 5 prize locations
45 # and 4 distances from outside in all directions
46 for pr in Monster_game_env.prize_locs+[None]:
47     if p==pr:
48         features += [x, 4-x, y, 4-y]
49     else:
50         features += [0, 0, 0, 0]
51 # fp04 feature for y when prize is at 0,4
52 # this knows about the wall to the right of the prize
53 if p==(0,4):
54     if x==0:
55         fp04 = y
56     elif y<3:
57         fp04 = y
58     else:
59         fp04 = 4-y
60 else:
61     fp04 = 0
62 features.append(fp04)
63 return features
64
65 def monster_ahead(x,y,action):
66     """returns 1 if the location expected to get to by doing
67     action from (x,y) can contain a monster.
68     """
69     if action == "right" and (x+1,y) in Monster_game_env.monster_locs:
70         return 1
71     elif action == "left" and (x-1,y) in Monster_game_env.monster_locs:
72         return 1
73     elif action == "up" and (x,y+1) in Monster_game_env.monster_locs:
74         return 1
75     elif action == "down" and (x,y-1) in Monster_game_env.monster_locs:
76         return 1
77     else:
78         return 0
79
80 def wall_ahead(x,y,action):
81     """returns 1 if there is a wall in the direction of action from (x,y).
82     This is complicated by the internal walls.
83     """
84     if action == "right" and (x==Monster_game_env.x_dim-1 or (x,y) in
85         Monster_game_env.vwalls):
86         return 1
87     elif action == "left" and (x==0 or (x-1,y) in Monster_game_env.vwalls):
88         return 1
89     elif action == "up" and y==Monster_game_env.y_dim-1:
90         return 1
91     elif action == "down" and y==0:
92         return 1

```

```

92     else:
93         return 0
94
95 def towards_prize(x,y,action,p):
96     """action goes in the direction of the prize from (x,y)"""
97     if p is None:
98         return 0
99     elif p==(0,4): # take into account the wall near the top-left prize
100         if action == "left" and (x>1 or x==1 and y<3):
101             return 1
102         elif action == "down" and (x>0 and y>2):
103             return 1
104         elif action == "up" and (x==0 or y<2):
105             return 1
106         else:
107             return 0
108     else:
109         px,py = p
110         if p==(4,4) and x==0:
111             if (action=="right" and y<3) or (action=="down" and y>2) or
112                 (action=="up" and y<2):
113                 return 1
114             else:
115                 return 0
116         if (action == "up" and y<py) or (action == "down" and py<y):
117             return 1
118         elif (action == "left" and px<x) or (action == "right" and x<px):
119             return 1
120         else:
121             return 0
122
123 def towards_repair(x,y,action):
124     """returns 1 if action is towards the repair station.
125     """
126     if action == "up" and (x>0 and y<4 or x==0 and y<2):
127         return 1
128     elif action == "left" and x>1:
129         return 1
130     elif action == "right" and x==0 and y<3:
131         return 1
132     elif action == "down" and x==0 and y>2:
133         return 1
134     else:
135         return 0

```

The following uses a simpler set of features. In particular, it only considers whether the action will most likely result in a monster position or a wall, and whether the action moves towards the current prize.

---

rGameFeature.py — (continued)

```

136 def simp_features(state,action):

```

```

137     """returns a list of feature values for the state-action pair
138     """
139     assert action in Monster_game_env.actions
140     (x,y,d,p) = state
141     # f1: would go to a monster
142     f1 = monster_ahead(x,y,action)
143     # f2: would crash into wall
144     f2 = wall_ahead(x,y,action)
145     # f3: action is towards a prize
146     f3 = towards_prize(x,y,action,p)
147     return [1,f1,f2,f3]

```

### 13.6.2 Feature-based RL learner

This learns a linear function approximation of the Q-values. It requires the function *get\_features* that given a state and an action returns a list of values for all of the features. Each environment requires this function to be provided.

```

_____rlFeatures.py — Feature-based Reinforcement Learner_____
11 import random
12 from rlProblem import RL_agent, epsilon_greedy, ucb
13 from display import Displayable
14 from utilities import argmaxe, flip
15 import rlGameFeature
16
17 class SARSA_LFA_learner(RL_agent):
18     """A SARSA with linear function approximation (LFA) learning agent has
19     """
20     def __init__(self, role, actions, discount,
21                 get_features=rlGameFeature.party_features4,
22                 exploration_strategy=epsilon_greedy, es_kwargs={},
23                 step_size=0.01, winit=0, method="SARSA_LFA"):
24         """role is the role of the agent (e.g., in a game)
25         actions is the set of actions the agent can do
26         discount is the discount factor
27         get_features is a function get_features(state,action) -> list of
28             feature values
29         exploration_strategy is the exploration function, default
30             "epsilon_greedy"
31         es_kwargs is extra keyword arguments of the exploration_strategy
32         step_size is gradient descent step size
33         winit is the initial value of the weights
34         method gives the method used to implement the role (for plotting)
35         """
36         RL_agent.__init__(self, actions)
37         self.role = role
38         self.discount = discount
39         self.exploration_strategy = exploration_strategy
40         self.es_kwargs = es_kwargs
41         self.get_features = get_features

```

```

39     self.step_size = step_size
40     self.winit = winit
41     self.method = method

```

The initial action is a random action. It remembers the state, and initializes the data structures.

```

-----rFeatures.py --- (continued)-----
43     def initial_action(self, state):
44         """ Returns the initial action; selected at random
45         Initialize Data Structures
46         """
47         self.action = RL_agent.initial_action(self, state)
48         self.features = self.get_features(state, self.action)
49         self.weights = [self.winit for f in self.features]
50         self.display(2, f"Initial State: {state} Action {self.action}")
51         self.display(2, "s\\ta\\tr\\ts\\tQ")
52         return self.action

```

*do* takes in the number of steps.

```

-----rFeatures.py --- (continued)-----
54
55     def q(self, state,action):
56         """returns Q-value of the state and action for current weights
57         """
58         return dot_product(self.weights, self.get_features(state,action))
59
60     def v(self,state):
61         return max(self.q(state, a) for a in self.actions)
62
63     def select_action(self, reward, next_state):
64         """do num_steps of interaction with the environment"""
65         feature_values = self.get_features(self.state,self.action)
66         oldQ = self.q(self.state,self.action)
67         next_action = self.exploration_strategy(next_state,
68             {a:self.q(next_state,a)
69                 for a in self.actions}, {})
70         nextQ = self.q(next_state,next_action)
71         delta = reward + self.discount * nextQ - oldQ
72         for i in range(len(self.weights)):
73             self.weights[i] += self.step_size * delta * feature_values[i]
74         self.display(2,self.state, self.action, reward, next_state,
75             self.q(self.state,self.action), delta, sep='\\t')
76         self.state = next_state
77         self.action = next_action
78         return self.action
79
80     def show_actions(self,state=None):
81         """prints the value for each action in a state.
82         This may be useful for debugging.
83         """

```

```

83         if state is None:
84             state = self.state
85         for next_act in self.actions:
86             print(next_act, dot_product(self.weights,
87                                     self.get_features(state, next_act)))
88
89 def dot_product(l1, l2):
90     return sum(e1*e2 for (e1, e2) in zip(l1, l2))

```

Test code:

```

rFeatures.py — (continued)
91 from rlProblem import Simulate
92 from rlExamples import Party_env, Monster_game_env
93 import rlGameFeature
94 from rlGUI import rlGUI
95
96 party = Party_env()
97 pa3 = SARSA_LFA_learner(party.name, party.actions, 0.9,
98                        rlGameFeature.party_features3)
99 # Simulate(pa3, party).start().go(300).plot()
100 pa4 = SARSA_LFA_learner(party.name, party.actions, 0.9,
101                        rlGameFeature.party_features4)
102 # Simulate(pa4, party).start().go(300).plot()
103
104 mon_env = Monster_game_env()
105 fa1 = SARSA_LFA_learner(mon_env.name, mon_env.actions, 0.9,
106                        rlGameFeature.monster_features)
107 # Simulate(fa1, mon_env).start().go(100000).plot()
108 fas1 = SARSA_LFA_learner(mon_env.name, mon_env.actions, 0.9,
109                        rlGameFeature.simp_features, method="LFA (simp features)")
110 # Simulate(fas1, mon_env).start().go(100000).plot()
111 # rlGUI(mon_env, SARSA_LFA_learner(mon_env.name, mon_env.actions, 0.9,
112                                rlGameFeature.monster_features))
113
114 from rlQLearner import test_RL
115 if __name__ == "__main__":
116     test_RL(SARSA_LFA_learner, es_kwargs={'epsilon':1}) # random exploration

```

**Exercise 13.8** How does the step-size affect performance? Try different step sizes (e.g., 0.1, 0.001, other sizes in between). Explain the behavior you observe. Which step size works best for this example. Explain what evidence you are basing your prediction on.

**Exercise 13.9** Does having extra features always help? Does it sometime help? Does whether it helps depend on the step size? Give evidence for your claims.

**Exercise 13.10** For each of the following first predict, then plot, then explain the behavior you observed:

- (a) SARSA\_LFA, Model-based learning (with 1 update per step) and Q-learning for 10,000 steps 20% exploring followed by 10,000 steps 100% exploiting

- (b) SARSA\_LFA, model-based learning and Q-learning for
- i) 100,000 steps 20% exploring followed by 100,000 steps 100% exploit
  - ii) 10,000 steps 20% exploring followed by 190,000 steps 100% exploit
- (c) Suppose your goal was to have the best accumulated reward after 200,000 steps. You are allowed to change the exploration rate at a fixed number of steps. For each of the methods, which is the best position to start exploiting more? Which method is better? What if you wanted to have the best reward after 10,000 or 1,000 steps?

Based on this evidence, explain when it is preferable to use SARSA\_LFA, Model-based learner, or Q-learning.

Important: you need to run each algorithm more than once. Your explanation should include the variability as well as the typical behavior.

**Exercise 13.11** In the call to `self.exploration_strategy`, what should the counts be? (The code above will fail for `ucb`, for example.) Think about the case where there are too many states. Suppose we are just learning for a neighborhood of a current state (e.g., a fixed number of steps away from the current state); how could the algorithm be modified to make sure it has at least explored the close neighborhood of the current state?

## 13.7 GUI for RL

This implements an interactive graphical user interface for reinforcement learners. It lets the user choose the actions and visualize the value function and/or the q-function.

Warning: `Exit` is not working, because it is only interrupting one thread.

```

rGUI.py — Reinforcement Learning GUI
11 import matplotlib.pyplot as plt
12 from matplotlib.widgets import Button, CheckButtons, TextBox
13 from rlProblem import Simulate
14
15 class rlGUI(object):
16     def __init__(self, env, agent):
17         """
18         """
19         self.env = env
20         self.agent = agent
21         self.state = self.env.state
22         self.x_dim = env.x_dim
23         self.y_dim = env.y_dim
24         if 'offsets' in vars(env): # 'offsets' is defined in environment
25             self.offsets = env.offsets
26         else: # should be more general
27             self.offsets = {'right':(0.25,0), 'up':(0,0.25),
28                             'left':(-0.25,0), 'down':(0,-0.25)}
28         # replace the exploration strategy with GUI

```

```

29     self.orig_exp_strategy = self.agent.exploration_strategy
30     self.agent.exploration_strategy = self.actionFromGUI
31     self.do_steps = 0
32     self.quit = False
33     self.action = None
34
35     def go(self):
36         self.q = self.agent.q
37         self.v = self.agent.v
38         try:
39             self.fig,self.ax = plt.subplots()
40             plt.subplots_adjust(bottom=0.2)
41             self.actButtons =
42                 {self.fig.text(0.8+self.offsets[a][0]*0.4,0.1+self.offsets[a][1]*0.1,a,
43                     bbox={'boxstyle':'square','color':'yellow','ec':'black'},
44                     picker=True):a #, fontsize=fontsize):a
45             for a in self.env.actions}
46             self.fig.canvas.mpl_connect('pick_event', self.sel_action)
47             self.sim = Simulate(self.agent, self.env)
48             self.show()
49             self.sim.start()
50             self.sim.go(1000000000000) # go forever
51         except ExitGUI:
52             plt.close()
53
54
55     def show(self):
56         #plt.ion() # interactive (why doesn't this work?)
57         self.qcheck = CheckButtons(plt.axes([0.2,0.05,0.25,0.075]),
58             ["show q-values","show policy","show
59             visits"])
60         self.qcheck.on_clicked(self.show_vals)
61         self.font_box = TextBox(plt.axes([0.125,0.05,0.05,0.05]),"Font:",
62             textalignment="center")
63         self.font_box.on_submit(self.set_font_size)
64         self.font_box.set_val(str(plt.rcParams['font.size']))
65         self.step_box = TextBox(plt.axes([0.5,0.05,0.1,0.05]),"",
66             textalignment="center")
67         self.step_box.set_val("100")
68         self.stepsButton = Button(plt.axes([0.6,0.05,0.075,0.05]), "steps",
69             color='yellow')
70         self.stepsButton.on_clicked(self.steps)
71         self.exitButton = Button(plt.axes([0.0,0.05,0.05,0.05]), "exit",
72             color='yellow')
73         self.exitButton.on_clicked(self.exit)
74         self.show_vals(None)
75
76     def set_font_size(self, s):
77         plt.rcParams.update({'font.size': eval(s)})

```

```

73     plt.draw()
74
75     def exit(self, s):
76         self.quit = True
77         raise ExitGUI
78
79     def show_vals(self, event):
80         self.ax.cla()
81         self.ax.set_title(f"{self.sim.step}: State: {self.state} Reward:
82         {self.env.reward} Sum rewards: {self.sim.sum_rewards}")
83         array = [[self.v(self.env.pos2state((x,y))) for x in
84                 range(self.x_dim)]
85                 for y in range(self.y_dim)]
86         self.ax.pcolormesh([x-0.5 for x in range(self.x_dim+1)],
87                             [x-0.5 for x in range(self.y_dim+1)],
88                             array, edgecolors='black', cmap='summer')
89         # for cmap see
90         https://matplotlib.org/stable/tutorials/colors/colormaps.html
91     if self.qcheck.get_status()[1]: # "show policy"
92         for x in range(self.x_dim):
93             for y in range(self.y_dim):
94                 state = self.env.pos2state((x,y))
95                 maxv = max(self.agent.q(state,a) for a in
96                     self.env.actions)
97                 for a in self.env.actions:
98                     xoff, yoff = self.offsets[a]
99                     if self.agent.q(state,a) == maxv:
100                        # draw arrow in appropriate direction
101                        self.ax.arrow(x,y,xoff*2,yoff*2,
102                                    color='red',width=0.05, head_width=0.2,
103                                    length_includes_head=True)
104
105     if goal := self.env.state2goal(self.state):
106         self.ax.add_patch(plt.Circle(goal, 0.1, color='lime'))
107     self.ax.add_patch(plt.Circle(self.env.state2pos(self.state), 0.1,
108                             color='w'))
109     if self.qcheck.get_status()[0]: # "show q-values"
110         self.show_q(event)
111     elif self.qcheck.get_status()[2] and 'visits' in vars(self.agent):
112         # "show visits"
113         self.show_visits(event)
114     else:
115         self.show_v(event)
116     self.ax.set_xticks(range(self.x_dim))
117     self.ax.set_xticklabels(range(self.x_dim))
118     self.ax.set_yticks(range(self.y_dim))
119     self.ax.set_yticklabels(range(self.y_dim))
120     plt.draw()
121
122     def sel_action(self, event):

```

```

116         self.action = self.actButtons[event.artist]
117
118     def show_v(self, event):
119         """show values"""
120         for x in range(self.x_dim):
121             for y in range(self.y_dim):
122                 state = self.env.pos2state((x,y))
123                 self.ax.text(x,y, "{val: .2f}".format(val=self.agent.v(state)), ha='center')
124
125     def show_q(self, event):
126         """show q-values"""
127         for x in range(self.x_dim):
128             for y in range(self.y_dim):
129                 state = self.env.pos2state((x,y))
130                 for a in self.env.actions:
131                     xoff, yoff = self.offsets[a]
132                     self.ax.text(x+xoff,y+yoff,
133                                 "{val: .2f}".format(val=self.agent.q(state,a)), ha='center')
134
135     def show_visits(self, event):
136         """show q-values"""
137         for x in range(self.x_dim):
138             for y in range(self.y_dim):
139                 state = self.env.pos2state((x,y))
140                 for a in self.env.actions:
141                     xoff, yoff = self.offsets[a]
142                     if state in self.agent.visits and a in
143                         self.agent.visits[state]:
144                         num_visits = self.agent.visits[state][a]
145                     else:
146                         num_visits = 0
147                     self.ax.text(x+xoff,y+yoff,
148                                 str(num_visits), ha='center')
149
150     def steps(self, event):
151         """do the steps given in step box"""
152         num_steps = int(self.step_box.text)
153         if num_steps > 0:
154             self.do_steps = num_steps-1
155             self.action = self.action_from_orig_exp_strategy()
156
157     def action_from_orig_exp_strategy(self):
158         """reutns the action from the original explorations strategy"""
159         visits = self.agent.visits[self.state] if 'visits' in
160             vars(self.agent) else {}
161         return
162             self.orig_exp_strategy(self.state, {a: self.agent.q(self.state, a)
163                 for a in self.agent.actions},
164                                     visits, **self.agent.es_kwargs)

```

```

162     def actionFromGUI(self, state, *args, **kwargs):
163         """called as the exploration strategy by the RL agent.
164         returns an action, either from the GUI or the original exploration
           strategy
           """
165         self.state = state
166         if self.do_steps > 0: # use the original
167             self.do_steps -= 1
168             return self.action_from_orig_exp_strategy()
169         else: # get action from the user
170             self.show_vals(None)
171             while self.action == None and not self.quit: #wait for user
172                 action
173                 plt.pause(0.05) # controls reaction time of GUI
174                 act = self.action
175                 self.action = None
176             return act
177
178     class ExitGUI(Exception):
179         pass
180
181     from rlExamples import Monster_game_env
182     from mdpExamples import MDptiny, Monster_game
183     from rlLearner import Q_learner, SARSA
184     from rlStochasticPolicy import StochasticPIAgent
185     from rlProblem import Env_from_ProblemDomain, epsilon_greedy, ucb
186     env = Env_from_ProblemDomain(MDptiny())
187     # env = Env_from_ProblemDomain(Monster_game())
188     # env = Monster_game_env()
189     # gui = rlGUI(env, Q_learner("Q", env.actions, 0.9)); gui.go()
190     # gui = rlGUI(env, SARSA("Q", env.actions, 0.9)); gui.go()
191     # gui = rlGUI(env, SARSA("Q", env.actions, 0.9, alpha_fun=lambda
           k:10/(9+k))); gui.go()
192     # gui = rlGUI(env, SARSA("SARSA-UCB", env.actions, 0.9,
           exploration_strategy = ucb, es_kwargs={'c':0.1})); gui.go()
193     # gui = rlGUI(env, StochasticPIAgent("Q", env.actions, 0.9,
           alpha_fun=lambda k:10/(9+k))); gui.go()

```

## Multiagent Systems

### 14.1 Minimax

Here we consider two-player zero-sum games. Here a player only wins when another player loses. This can be modeled as where there is a single utility which one agent (the maximizing agent) is trying minimize and the other agent (the minimizing agent) is trying to minimize.

#### 14.1.1 Creating a two-player game

```
masProblem.py — A Multiagent Problem
11 from display import Displayable
12
13 class Node(Displayable):
14     """A node in a search tree. It has a
15     name a string
16     isMax is True if it is a maximizing node, otherwise it is minimizing
17     node
18     children is the list of children
19     value is what it evaluates to if it is a leaf.
20     """
21     def __init__(self, name, isMax, value, children):
22         self.name = name
23         self.isMax = isMax
24         self.value = value
25         self.allchildren = children
26
27     def isLeaf(self):
28         """returns true of this is a leaf node"""
29         return self.allchildren is None
```

```

29
30     def children(self):
31         """returns the list of all children."""
32         return self.allchildren
33
34     def evaluate(self):
35         """returns the evaluation for this node if it is a leaf"""
36         return self.value

```

The following gives the tree from Figure 11.5 of the book. Note how 888 is used as a value here, but never appears in the trace.

```

masProblem.py — (continued)
38 fig10_5 = Node("a", True, None, [
39     Node("b", False, None, [
40         Node("d", True, None, [
41             Node("h", False, None, [
42                 Node("h1", True, 7, None),
43                 Node("h2", True, 9, None)]]),
44             Node("i", False, None, [
45                 Node("i1", True, 6, None),
46                 Node("i2", True, 888, None)]]),
47         Node("e", True, None, [
48             Node("j", False, None, [
49                 Node("j1", True, 11, None),
50                 Node("j2", True, 12, None)]]),
51         Node("k", False, None, [
52             Node("k1", True, 888, None),
53             Node("k2", True, 888, None)]])]),
54     Node("c", False, None, [
55         Node("f", True, None, [
56             Node("l", False, None, [
57                 Node("l1", True, 5, None),
58                 Node("l2", True, 888, None)]]),
59         Node("m", False, None, [
60             Node("m1", True, 4, None),
61             Node("m2", True, 888, None)]]),
62     Node("g", True, None, [
63         Node("n", False, None, [
64             Node("n1", True, 888, None),
65             Node("n2", True, 888, None)]]),
66     Node("o", False, None, [
67         Node("o1", True, 888, None),
68         Node("o2", True, 888, None)]])])])])

```

The following is a representation of a **magic-sum game**, where players take turns picking a number in the range [1, 9], and the first player to have 3 numbers that sum to 15 wins. Note that this is a syntactic variant of **tic-tac-toe** or **naughts and crosses**. To see this, consider the numbers on a **magic square** (Figure 14.1); 3 numbers that add to 15 correspond exactly to the winning positions

6	1	8
7	5	3
2	9	4

Figure 14.1: Magic Square

of tic-tac-toe played on the magic square.

Note that we do not remove symmetries. (What are the symmetries? How do the symmetries of tic-tac-toe translate here?)

```

masProblem.py — (continued)
70
71 class Magic_sum(Node):
72     def __init__(self, xmove=True, last_move=None,
73                 available=[1,2,3,4,5,6,7,8,9], x=[], o=[]):
74         """This is a node in the search for the magic-sum game.
75         xmove is True if the next move belongs to X.
76         last_move is the number selected in the last move
77         available is the list of numbers that are available to be chosen
78         x is the list of numbers already chosen by x
79         o is the list of numbers already chosen by o
80         """
81         self.isMax = self.xmove = xmove
82         self.last_move = last_move
83         self.available = available
84         self.x = x
85         self.o = o
86         self.allchildren = None #computed on demand
87         lm = str(last_move)
88         self.name = "start" if not last_move else "o="+lm if xmove else
            "x="+lm
89
90     def children(self):
91         if self.allchildren is None:
92             if self.xmove:
93                 self.allchildren = [
94                     Magic_sum(xmove = not self.xmove,
95                               last_move = sel,
96                               available = [e for e in self.available if e is
97                                             not sel],
98                               x = self.x+[sel],
99                               o = self.o)
100                    for sel in self.available]
101             else:
102                 self.allchildren = [
103                     Magic_sum(xmove = not self.xmove,
104                               last_move = sel,
105                               available = [e for e in self.available if e is
106                                             not sel],

```

```

105         x = self.x,
106         o = self.o+[sel])
107         for sel in self.available]
108     return self.allchildren
109
110 def isLeaf(self):
111     """A leaf has no numbers available or is a win for one of the
112     players.
113     We only need to check for a win for o if it is currently x's turn,
114     and only check for a win for x if it is o's turn (otherwise it would
115     have been a win earlier).
116     """
117     return (self.available == [] or
118             (sum_to_15(self.last_move,self.o)
119              if self.xmove
120              else sum_to_15(self.last_move,self.x)))
121
122 def evaluate(self):
123     if self.xmove and sum_to_15(self.last_move,self.o):
124         return -1
125     elif not self.xmove and sum_to_15(self.last_move,self.x):
126         return 1
127     else:
128         return 0
129
130 def sum_to_15(last,selected):
131     """is true if last, together with two other elements of selected sum to
132     15.
133     """
134     return any(last+a+b == 15
135                for a in selected if a != last
136                for b in selected if b != last and b != a)

```

### 14.1.2 Minimax and $\alpha$ - $\beta$ Pruning

This is a naive depth-first **minimax algorithm**:

```

-----masMiniMax.py — Minimax search with alpha-beta pruning-----
11 def minimax(node,depth):
12     """returns the value of node, and a best path for the agents
13     """
14     if node.isLeaf():
15         return node.evaluate(),None
16     elif node.isMax:
17         max_score = float("-inf")
18         max_path = None
19         for C in node.children():
20             score,path = minimax(C,depth+1)
21             if score > max_score:
22                 max_score = score
23                 max_path = C.name,path

```

```

24         return max_score,max_path
25     else:
26         min_score = float("inf")
27         min_path = None
28         for C in node.children():
29             score,path = minimax(C,depth+1)
30             if score < min_score:
31                 min_score = score
32                 min_path = C.name,path
33     return min_score,min_path

```

The following is a depth-first minimax with  $\alpha$ - $\beta$  pruning. It returns the value for a node as well as a best path for the agents.

```

masMiniMax.py — (continued)
35 def minimax_alpha_beta(node,alpha,beta,depth=0):
36     """node is a Node, alpha and beta are cutoffs, depth is the depth
37     returns value, path
38     where path is a sequence of nodes that results in the value
39     """
40     node.display(2," *depth,"minimax_alpha_beta(",node.name,", ",alpha, ",
41     ", beta,")")
42     best=None # only used if it will be pruned
43     if node.isLeaf():
44         node.display(2," *depth,"returning leaf value",node.evaluate())
45         return node.evaluate(),None
46     elif node.isMax:
47         for C in node.children():
48             score,path = minimax_alpha_beta(C,alpha,beta,depth+1)
49             if score >= beta: # beta pruning
50                 node.display(2," *depth,"pruned due to
51                 beta=",beta,"C=",C.name)
52                 return score, None
53             if score > alpha:
54                 alpha = score
55                 best = C.name, path
56             node.display(2," *depth,"returning max alpha",alpha,"best",best)
57             return alpha,best
58     else:
59         for C in node.children():
60             score,path = minimax_alpha_beta(C,alpha,beta,depth+1)
61             if score <= alpha: # alpha pruning
62                 node.display(2," *depth,"pruned due to
63                 alpha=",alpha,"C=",C.name)
64                 return score, None
65             if score < beta:
66                 beta=score
67                 best = C.name,path
68             node.display(2," *depth,"returning min beta",beta,"best=",best)
69             return beta,best

```

Testing:

```

masMiniMax.py — (continued)
68 from masProblem import fig10_5, Magic_sum, Node
69
70 # Node.max_display_level=2 # print detailed trace
71 # minimax_alpha_beta(fig10_5, -9999, 9999,0)
72 # minimax_alpha_beta(Magic_sum(), -9999, 9999,0)
73
74 #To see how much time alpha-beta pruning can save over minimax, uncomment
  the following:
75 ## import timeit
76 ## timeit.Timer("minimax(Magic_sum(),0)",setup="from __main__ import
  minimax, Magic_sum"
77 ##           ).timeit(number=1)
78 ## trace=False
79 ## timeit.Timer("minimax_alpha_beta(Magic_sum(), -9999, 9999,0)",
80 ##           setup="from __main__ import minimax_alpha_beta, Magic_sum"
81 ##           ).timeit(number=1)

```

## 14.2 Multiagent Learning

The next code is for multiple agents that learn when interacting with other agents. The main difference with the simulator from the last chapter is that the games take actions from all agents and provide a separate reward to each agent. Any of the reinforcement learning agents from the last chapter can be used.

### 14.2.1 Simulating Multiagent Interaction with an Environment

The simulation for a game passes the joint action from all agents to the environment, which returns a tuple of rewards – one for each agent – and the next state.

```

masLearn.py — Multiagent learning
11 from display import Displayable
12 import matplotlib.pyplot as plt
13 from rlProblem import RL_agent
14
15 class SimulateGame(Displayable):
16     def __init__(self, game, agent_types):
17         #self.max_display_level = 3
18         self.game = game
19         self.agents = [agent_types[i](game.players[i], game.actions[i], 0)
20             for i in range(game.num_agents)] # list of agents
21         self.action_dists = [{act:0 for act in game.actions[i]} for i in
22             range(game.num_agents)]
23         self.action_history = []
24         self.state_history = []
25         self.reward_history = []

```

```

24     self.dist = {}
25     self.dist_history = []
26     self.actions = tuple(ag.initial_action(game.initial_state) for ag
27         in self.agents)
28     self.num_steps = 0
29
30     def go(self, steps):
31         for i in range(steps):
32             self.num_steps += 1
33             (self.rewards, state) = self.game.play(self.actions)
34             self.display(3, f"In go rewards={self.rewards}, state={state}")
35             self.reward_history.append(self.rewards)
36             self.state_history.append(state)
37             self.actions = tuple(agent.select_action(reward, state)
38                 for (agent, reward) in
39                     zip(self.agents, self.rewards))
40             self.action_history.append(self.actions)
41             for i in range(self.game.num_agents):
42                 self.action_dists[i][self.actions[i]] += 1
43                 self.dist_history.append([a:i for (a,i) in elt.items() for
44                     elt in self.action_dists]) # deep copy
45             #print("Scores:", ' '.join(f"{self.agents[i].role} average
46                 reward={ag.total_score/self.num_steps}" for ag in self.agents))
47             print("Distributions:", '
48                 '.join(str({a:self.dist_history[-1][i][a]/sum(self.dist_history[-1][i].values())
49                     for a in self.game.actions[i]})
50                     for i in
51                         range(self.game.num_agents)))
52             #return self.reward_history, self.action_history
53
54     def action_dist(self, which_actions=[1,1]):
55         """ which actions is [a0,a1]
56         returns the empirical distribution of actions for agents,
57         where ai specifies the index of the actions for agent i
58         remove this??
59         """
60         return [sum(1 for a in sim.action_history
61             if
62                 a[i]==gm.actions[i][which_actions[i]])/len(sim.action_history)
63             for i in range(2)]

```

The plotting shows how the empirical distributions of the first two agents changes as the learning continues.

masLearn.py — (continued)

```

57     def plot_dynamics(self, x_action=0, y_action=0):
58         plt.ion() # make it interactive
59         agents = self.agents
60         x_act = self.game.actions[0][x_action]
61         y_act = self.game.actions[1][y_action]

```

```

62 plt.xlabel(f"Probability {self.game.players[0]}
    {self.agents[0].actions[x_action]}")
63 plt.ylabel(f"Probability {self.game.players[1]}
    {self.agents[1].actions[y_action]}")
64 plt.plot([self.dist_history[i][0][x_act]/sum(self.dist_history[i][0].values())
    for i in range(len(self.dist_history))],
65         [self.dist_history[i][1][y_act]/sum(self.dist_history[i][1].values())
    for i in range(len(self.dist_history))])
66 plt.legend()
67 plt.savefig('soccerplot.pdf') # if you want to save plot
68 plt.show()

```

## 14.2.2 Example Games

The following are games from Poole and Mackworth [2023].

masLearn.py — (continued)

```

70 class ShoppingGame(Displayable):
71     def __init__(self):
72         self.num_agents = 2
73         self.states = ['s']
74         self.initial_state = 's'
75         self.actions = [['shopping', 'football']]*2
76         self.players = ['football-preferrer goes to', 'shopping-preferrer
    goes to']
77
78     def play(self, actions):
79         """Given (action1,action2) returns (resulting_state, (reward1,
    reward2))
80         """
81         return ({('football', 'football'): (2, 1),
82                 ('football', 'shopping'): (0, 0),
83                 ('shopping', 'football'): (0, 0),
84                 ('shopping', 'shopping'): (1, 2)
85                 }[actions], 's')
86
87 class SoccerGame(Displayable):
88     def __init__(self):
89         self.num_agents = 2
90         self.states = ['s']
91         self.initial_state = 's'
92         self.initial_state = 's'
93         self.actions = [['right', 'left']]*2
94         self.players = ['goalkeeper', 'kicker']
95
96     def play(self, actions):
97         """Given (action1,action2) returns (resulting_state, (reward1,
    reward2))
98         resulting state is 's'
99         """

```

```

100         return ({('left', 'left'): (0.6, 0.4),
101                 ('left', 'right'): (0.3, 0.7),
102                 ('right', 'left'): (0.2, 0.8),
103                 ('right', 'right'): (0.9, 0.1)
104                }[actions], 's')
105
106 class GameShow(Displayable):
107     def __init__(self):
108         self.num_agents = 2
109         self.states = ['s']
110         self.initial_state = 's'
111         self.actions = [['takes', 'gives']]*2
112         self.players = ['Agent 1', 'Agent 2']
113
114     def play(self, actions):
115         return ({('takes', 'takes'): (1, 1),
116                 ('takes', 'gives'): (11, 0),
117                 ('gives', 'takes'): (0, 11),
118                 ('gives', 'gives'): (10, 10)
119                }[actions], 's')
120
121
122 class UniqueNEGameExample(Displayable):
123     def __init__(self):
124         self.num_agents = 2
125         self.states = ['s']
126         self.initial_state = 's'
127         self.actions = [['a1', 'b1', 'c1'], ['d2', 'e2', 'f2']]
128         self.players = ['agent 1 does', 'agent 2 does']
129
130     def play(self, actions):
131         return ({('a1', 'd2'): (3, 5),
132                 ('a1', 'e2'): (5, 1),
133                 ('a1', 'f2'): (1, 2),
134                 ('b1', 'd2'): (1, 1),
135                 ('b1', 'e2'): (2, 9),
136                 ('b1', 'f2'): (6, 4),
137                 ('c1', 'd2'): (2, 6),
138                 ('c1', 'e2'): (4, 7),
139                 ('c1', 'f2'): (0, 8)
140                }[actions], 's')

```

### 14.2.3 Testing Games and Environments

---

masLearn.py — (continued)

---

```

142 # Choose a game:
143 # gm = ShoppingGame()
144 # gm = SoccerGame()
145 # gm = GameShow()

```

```

146 # gm = UniqueNEGameExample()
147
148 from rlQLearner import Q_learner
149 from rlProblem import RL_agent
150 from rlStochasticPolicy import StochasticPIAgent
151 # Choose one of the combinations of learners:
152 # sim=SimulateGame(gm,[StochasticPIAgent, StochasticPIAgent]);
153     sim.go(10000)
154 # sim= SimulateGame(gm,[Q_learner, Q_learner]); sim.go(10000)
155 # sim=SimulateGame(gm,[Q_learner, StochasticPIAgent]); sim.go(10000)
156
157 # sim.plot_dynamics()
158
159 # empirical proportion that agents did their action at index 1:
160 # sim.action_dist([1,1])
161
162 # (unnormalized) empirical distribution for agent 0
163 # sim.agents[0].dist

```

**Exercise 14.1** Consider the alternative ways to implement stochastic policy iteration of Exercise 13.2.

- (a) What value(s) of  $c$  converge for the soccer game? Explain your results.
- (b) Suggest another method that works well for the soccer game, the other games and other RL environments.

**Exercise 14.2** For the soccer game, how can a `Q_learner` be regularly beaten? Assume that random number generator is secret. (Hint: can you predict what it will do?) What happens when it is played against an adversary that knows how it learns? What happens if two of these agents are played against each other? Can a `StochasticPIAgent` be defeated in the same way?

**Exercise 14.3** Try the game show game (prisoner's dilemma) with two `StochasticPIAgent` agents and `alpha_fun=lambda k:0.1`. Try also 0.01. Why does this work qualitatively different? Is this better?

## Individuals and Relations

Here we implement top-down proofs for datalog and logic programming. This is much less efficient than Prolog, which is typically implemented by compiling to an abstract machine. If you want to do serious work, we suggest using Prolog; SWI Prolog (<https://www.swi-prolog.org>) is good.

### 15.1 Representing Datalog and Logic Programs

The following extends the knowledge bases of Chapter 5 to include logical variables. In that chapter, atoms did not have structure and were represented as strings. Here atoms can have arguments including variables (defined below) and constants (represented by strings).

Function symbols have the same representation as atoms. To make unification simpler and for when we treat clauses as data, `Func` is defined as an abbreviation for `Atom`.

```
_____logicRelation.py — Datalog and Logic Programs _____  
11 from display import Displayable  
12 import logicProblem  
13  
14 class Var(Displayable):  
15     """A logical variable"""  
16     def __init__(self, name):  
17         """name"""  
18         self.name = name  
19  
20     def __str__(self):  
21         return self.name  
22     __repr__ = __str__  
23
```

```

24     def __eq__(self, other):
25         return isinstance(other, Var) and self.name == other.name
26     def __hash__(self):
27         return hash(self.name)
28
29 class Atom(object):
30     """An atom"""
31     def __init__(self, name, args):
32         self.name = name
33         self.args = args
34
35     def __str__(self):
36         return f"{self.name}({' ', '.join(str(a) for a in self.args)}'"
37     __repr__ = __str__
38
39 Func = Atom # same syntax is used for function symbols

```

The following extends Clause of Section 5.1 to also include a set of logical variables in the clause. It also allows for atoms that are strings (as in Chapter 5) and makes them into atoms.

---

```

                                     logicRelation.py — (continued)
41 class Clause(logicProblem.Clause):
42     next_index=0
43     def __init__(self, head, *args, **nargs):
44         if not isinstance(head, Atom):
45             head = Atom(head)
46         logicProblem.Clause.__init__(self, head, *args, **nargs)
47         self.logical_variables = log_vars([self.head, self.body], set())
48
49     def rename(self):
50         """create a unique copy of the clause"""
51         if self.logical_variables:
52             sub = {v: Var(f"{v.name}_{Clause.next_index}") for v in
53                   self.logical_variables}
54             Clause.next_index += 1
55             return Clause(apply(self.head, sub), apply(self.body, sub))
56         else:
57             return self
58
59     def log_vars(exp, vs):
60         """the union the logical variables in exp and the set vs"""
61         if isinstance(exp, Var):
62             return {exp}|vs
63         elif isinstance(exp, Atom):
64             return log_vars(exp.name, log_vars(exp.args, vs))
65         elif isinstance(exp, (list, tuple)):
66             for e in exp:
67                 vs = log_vars(e, vs)
68         return vs

```

## 15.2 Unification

---

 logicRelation.py — (continued)
 

---

```

69 unifdisp = Var(None) # for display
70
71 def unify(t1,t2):
72     e = [(t1,t2)]
73     s = {} # empty dictionary
74     while e:
75         (a,b) = e.pop()
76         unifdisp.display(2,f"unifying{(a,b)}, e={e},s={s}")
77         if a != b:
78             if isinstance(a,Var):
79                 e = apply(e,{a:b})
80                 s = apply(s,{a:b})
81                 s[a]=b
82             elif isinstance(b,Var):
83                 e = apply(e,{b:a})
84                 s = apply(s,{b:a})
85                 s[b]=a
86             elif isinstance(a,Atom) and isinstance(b,Atom) and
87                 a.name==b.name and len(a.args)==len(b.args):
88                 e += zip(a.args,b.args)
89             elif isinstance(a,(list,tuple)) and isinstance(b,(list,tuple))
90                 and len(a)==len(b ):
91                 e += zip(a,b)
92             else:
93                 return False
94     return s
95
96 def apply(e,sub):
97     """e is an expression
98     sub is a {var:val} dictionary
99     returns e with all occurrence of var replaces with val"""
100    if isinstance(e,Var) and e in sub:
101        return sub[e]
102    if isinstance(e,Atom):
103        return Atom(e.name, apply(e.args,sub))
104    if isinstance(e,list):
105        return [apply(a,sub) for a in e]
106    if isinstance(e,tuple):
107        return tuple(apply(a,sub) for a in e)
108    if isinstance(e,dict):
109        return {k:apply(v,sub) for (k,v) in e.items()}
110    else:
111        return e

```

Test cases:

---

 logicRelation.py — (continued)
 

---

```

111 | ### Test cases:
112 | # unifdisp.max_display_level = 2 # show trace
113 | e1 = Atom('p',[Var('X'),Var('Y'),Var('Y')])
114 | e2 = Atom('p',['a',Var('Z'),'b'])
115 | # apply(e1,{Var('Y'):'b'})
116 | # unify(e1,e2)
117 | e3 = Atom('p',['a',Var('Y'),Var('Y')])
118 | e4 = Atom('p',[Var('Z'),Var('Z'),'b'])
119 | # unify(e3,e4)

```

## 15.3 Knowledge Bases

The following modifies KB of Section 5.1 so that clause indexing is only on the predicate symbol of the head of clauses.

```

_____logicRelation.py — (continued)_____
121 | class KB(logicProblem.KB):
122 |     """A first-order knowledge base.
123 |         only the indexing is changed to index on name of the head."""
124 |
125 |     def add_clause(self, c):
126 |         """Add clause c to clause dictionary"""
127 |         if c.head.name in self.atom_to_clauses:
128 |             self.atom_to_clauses[c.head.name].append(c)
129 |         else:
130 |             self.atom_to_clauses[c.head.name] = [c]

```

simp\_KB is the simple knowledge base of Figure 15.1 of Poole and Mackworth [2023].

```

_____relnExamples.py — Relational Knowledge Base Example_____
11 | from logicRelation import Var, Atom, Clause, KB
12 |
13 | simp_KB = KB([
14 |     Clause(Atom('in',['kim','r123'])),
15 |     Clause(Atom('part_of',['r123','cs_building'])),
16 |     Clause(Atom('in',[Var('X'),Var('Y')]),
17 |             [Atom('part_of',[Var('Z'),Var('Y')]),
18 |               Atom('in',[Var('X'),Var('Z')])])
19 | ])

```

elect\_KB is the relational version of the knowledge base for the electrical system of a house, as described in Example 15.11 of Poole and Mackworth [2023].

```

_____relnExamples.py — (continued)_____
21 | # define abbreviations to make the clauses more readable:
22 | def lit(x): return Atom('lit',[x])
23 | def light(x): return Atom('light',[x])
24 | def ok(x): return Atom('ok',[x])
25 | def live(x): return Atom('live',[x])
26 | def connected_to(x,y): return Atom('connected_to',[x,y])

```

```

27 def up(x): return Atom('up',[x])
28 def down(x): return Atom('down',[x])
29
30 L = Var('L')
31 W = Var('W')
32 W1 = Var('W1')
33
34 elect_KB = KB([
35     # lit(L) is true if light L is lit.
36     Clause(lit(L),
37             [light(L),
38              ok(L),
39              live(L)]),
40
41     # live(W) is true if W is live (i.e., current will flow through it)
42     Clause(live(W),
43             [connected_to(W,W1),
44              live(W1)]),
45
46     Clause(live('outside')),
47
48     # light(L) is true if L is a light
49     Clause(light('l1')),
50     Clause(light('l2')),
51
52     # connected_to(W0,W1) is true if W0 is connected to W1 such that
53     # current will flow from W1 to W0.
54
55     Clause(connected_to('l1','w0')),
56     Clause(connected_to('w0','w1'),
57             [ up('s2'), ok('s2')]),
58     Clause(connected_to('w0','w2'),
59             [ down('s2'), ok('s2')]),
60     Clause(connected_to('w1','w3'),
61             [ up('s1'), ok('s1')]),
62     Clause(connected_to('w2','w3'),
63             [ down('s1'), ok('s1')]),
64     Clause(connected_to('l2','w4')),
65     Clause(connected_to('w4','w3'),
66             [ up('s3'), ok('s3')]),
67     Clause(connected_to('p1','w3')),
68     Clause(connected_to('w3','w5'),
69             [ ok('cb1')]),
70     Clause(connected_to('p2','w6')),
71     Clause(connected_to('w6','w5'),
72             [ ok('cb2')]),
73     Clause(connected_to('w5','outside'),
74             [ ok('outside_connection')]),
75
76     # up(S) is true if switch S is up

```

```

77 | # down(S) is true if switch S is down
78 | Clause(down('s1')),
79 | Clause(up('s2')),
80 | Clause(up('s3')),
81 |
82 | # ok(L) is true if K is working. Everything is ok:
83 | Clause(ok(L)),
84 | ])

```

## 15.4 Top-down Proof Procedure

The top-down proof procedure is the one defined in Section 15.5.4 of Poole and Mackworth [2023] and shown in Figure 15.5. It is like `prove` defined in Section 5.3. It implements the iterator interface so that answers can be generated one at a time (or put in a list), and returns answers. To implement “choose” it loops over all alternatives and *yields* (returns one element at a time) the successful proofs.

```

_____logicRelation.py — (continued)_____
132 | def ask(self, query):
133 |     """self is the current KB
134 |     query is a list of atoms to be proved
135 |     generates {variable:value} dictionary"""
136 |
137 |     qvars = list(log_vars(query, set()))
138 |     for ans in self.prove(qvars, query):
139 |         yield {x:v for (x,v) in zip(qvars,ans)}
140 |
141 | def ask_all(self, query):
142 |     """returns a list of all answers to the query given kb"""
143 |     return list(self.ask(query))
144 |
145 | def ask_one(self, query):
146 |     """returns an answer to the query given kb or None of there are no
147 |     answers"""
148 |     for ans in self.ask(query):
149 |         return ans
150 |
151 | def prove(self, ans, ans_body, indent=""):
152 |     """enumerates the proofs for ans_body
153 |     ans_body is a list of atoms to be proved
154 |     ans is the list of values of the query variables
155 |     """
156 |     self.display(2,indent,f"(yes({ans}) <-", " & ".join(str(a) for a in
157 |     ans_body))
158 |     if ans_body==[]:
159 |         yield ans
160 |     else:

```

```

159         selected, remaining = self.select_atom(ans_body)
160         if self.built_in(selected):
161             yield from self.eval_built_in(ans, selected, remaining,
162                                     indent)
163         else:
164             for chosen_clause in self.atom_to_clauses[selected.name]:
165                 clause = chosen_clause.rename() # rename variables
166                 sub = unify(selected, clause.head)
167                 if sub is not False:
168                     self.display(3,indent,"KB.prove: selected=",
169                                 selected, "clause=",clause,"sub=",sub)
170                     resans = apply(ans,sub)
171                     new_ans_body = apply(clause.body+remaining, sub)
172                     yield from self.prove(resans, new_ans_body, indent+"
173                                     ")
174
175     def select_atom(self,lst):
176         """given list of atoms, return (selected atom, remaining atoms)
177         """
178         return lst[0],lst[1:]
179
180     def built_in(self,atom):
181         return atom.name in ['lt','triple']
182
183     def eval_built_in(self,ans, selected, remaining, indent):
184         if selected.name == 'lt': # less than
185             [a1,a2] = selected.args
186             if a1 < a2:
187                 yield from self.prove(ans, remaining, indent+" ")
188         if selected.name == 'triple': # use triple store (AIFCA Ch 16)
189             yield from self.eval_triple(ans, selected, remaining, indent)

```

---

relnExamples.py — (continued)

---

```

86 # Example Queries:
87 # simp_KB.max_display_level = 2 # show trace
88 # ask_all(simp_KB, [Atom('in',[Var('A'),Var('B')])])
89
90 def test_ask_all(kb=simp_KB, query=[Atom('in',[Var('A'),Var('B')])],
91                 res=[{ Var('A'):'kim',Var('B'):'r123'},
92                       {Var('A'):'kim',Var('B'):'cs_building'}]):
93     ans= kb.ask_all(query)
94     assert ans == res, f"ask_all({query}) gave answer {ans}"
95     print("ask_all: Passed unit test")
96
97 if __name__ == "__main__":
98     test_ask_all()
99
100 # elect_KB.max_display_level = 2 # show trace
101 # elect_KB.ask_all([light('l1')])
102 # elect_KB.ask_all([light('l6')])

```

```

102 # elect_KB.ask_all([up(Var('X'))])
103 # elect_KB.ask_all([connected_to('w0',W)])
104 # elect_KB.ask_all([connected_to('w1',W)])
105 # elect_KB.ask_all([connected_to(W,'w3')])
106 # elect_KB.ask_all([connected_to(W1,W)])
107 # elect_KB.ask_all([live('w6')])
108 # elect_KB.ask_all([live('p1')])
109 # elect_KB.ask_all([Atom('lit',[L])])
110 # elect_KB.ask_all([Atom('lit',['l2']), live('p1')])
111 # elect_KB.ask_all([live(L)])

```

**Exercise 15.1** Implement ask-ther-user similar to Section 5.3. Augment this by allowing the user to specify which instances satisfy a instances. For example, by asking the user “for what X is w1 connected to X?”; or perhaps in a more user friendly way.

## 15.5 Logic Program Example

The following is an append program and the query of Example 15.30 of Poole and Mackworth [2023].

```

append(nil,W,W).
append(c(A,X),Y,c(A,Z)) <-
    append(X,Y,Z).

```

The term  $c(A,X)$  is represented using Atom  
In Prolog syntax:

```

append(nil,W,W).
append([A|X],Y,[A|Z]) :-
    append(X,Y,Z).

```

The value if lst is [1, i, s, t]. The query is

```
? append(F,[L],[1,i,s,t]).
```

We first define some constants and functions to make it more readable.

```

----- logicRelation.py ----- (continued) -----
188 A = Var('A')
189 W = Var('W')
190 X = Var('X')
191 Y = Var('Y')
192 Z = Var('Z')
193 def cons(h,t): return Atom('cons',[h,t])
194 def append(a,b,c): return Atom('append',[a,b,c])
195
196 app_KB = KB([
197     Clause(append('nil',W,W)),
198     Clause(append(cons(A,X), Y, cons(A,Z)),
199         [append(X,Y,Z)])

```

```
200     ])  
201  
202     F = Var('F')  
203     lst = cons('l',cons('i',cons('s',cons('t','nil'))))  
204     # app_KB.max_display_level = 2 #show derivation  
205     #ask_all(app_KB, [append(F,cons(A,'nil'), lst)])  
206     # Think about the expected answer before trying:  
207     #ask_all(app_KB, [append(X, Y, lst)])  
208     #ask_all(app_KB, [append(lst, lst, L), append(X, cons('s',Y), L)])
```



## Knowledge Graphs and Ontologies

### 16.1 Triple Store

A triple store provides efficient indexing for triples. For any combination of the subject-verb-object being provided or not, it can efficiently retrieve the corresponding triples. This should be as fast as commercial triple stores, but can probably handle fewer triples, as it is not optimized for space. It also have fewer bells and whistles (e.g., ways to visualize triples and traverse the graph).

A triple store implements an index that covers all cases of where the subject, verb, or object are provided or not. The unspecified parts are given using Q (with value '?'). Thus, for example, `index[(Q, vrb, Q)]` is the list of triples with verb `vrb`. `index[(sub, Q, obj)]` is the list of triples with subject `sub` and object `obj`.

```
_____knowledgeGraph.py — Knowledge graph triple store _____
11 from display import Displayable
12
13 class TripleStore(Displayable):
14     Q = '?' # query position
15
16     def __init__(self):
17         self.index = {}
18
19     def add(self, triple):
20         (sb,vb,ob) = triple
21         Q = self.Q # make it easier to read
22         add_to_index(self.index, (Q,Q,Q), triple)
23         add_to_index(self.index, (Q,Q,ob), triple)
```

```

24     add_to_index(self.index, (Q,vb,Q), triple)
25     add_to_index(self.index, (Q,vb,ob), triple)
26     add_to_index(self.index, (sb,Q,Q), triple)
27     add_to_index(self.index, (sb,Q,ob), triple)
28     add_to_index(self.index, (sb,vb,Q), triple)
29     add_to_index(self.index, triple, triple)
30
31     def __len__(self):
32         """number of triples in the triple store"""
33         return len(self.index[(Q,Q,Q)])

```

The lookup method returns a list of triples that match a pattern. The pattern is a triple of the form  $(i, j, k)$  where each of  $i$ ,  $j$ , and  $k$  is either “Q” or a given value; specifying whether the subject, verb, and object are provided in the query or not. `lookup((Q,Q,Q))` returns all triples. `lookup((s,v,o))` can be used to check whether the triple  $(s, v, o)$  is in the triple store; it returns `[]` if the triple is not in the knowledge graph, and `[(s, v, o)]` if it is.

knowledgeGraph.py — (continued)

```

35     def lookup(self, query):
36         """pattern is a triple of the form (i,j,k) where
37             each i, j, k is either Q or a value for the
38             subject, verb and object respectively.
39             returns all triples with the specified non-Q vars in corresponding
40             position
41         """
42         if query in self.index:
43             return self.index[query]
44         else:
45             return []
46
47     def add_to_index(dict, key, value):
48         if key in dict:
49             dict[key].append(value)
50         else:
51             dict[key] = [value]

```

Here is a simple test triple store. In Wikidata Q262802 denotes the football (soccer) player Christine Sinclair, P27 is the country of citizenship, and Q16 is Canada.

knowledgeGraph.py — (continued)

```

52 # test cases:
53 sts = TripleStore() # simple triple store
54 Q = TripleStore.Q # makes it easier to read
55 sts.add(('entity/Q262802', 'http://schema.org/name', "Christine Sinclair"))
56 sts.add(('entity/Q262802', '/prop/direct/P27', '/entity/Q16'))
57 sts.add(('entity/Q16', 'http://schema.org/name', "Canada"))
58
59 # sts.lookup(('entity/Q262802', Q, Q))
60 # sts.lookup((Q, 'http://schema.org/name', Q))

```

```

61 # sts.lookup((Q, 'http://schema.org/name', "Canada"))
62 # sts.lookup(('entity/Q16', 'http://schema.org/name', "Canada"))
63 # sts.lookup(('entity/Q262802', 'http://schema.org/name', "Canada"))
64 # sts.lookup((Q,Q,Q))
65
66 def test_kg(kg=sts, q=('entity/Q262802',Q,Q),
67     res=[('entity/Q262802', 'http://schema.org/name', "Christine
68     Sinclair"), ('entity/Q262802', '/prop/direct/P27', '/entity/Q16')]):
69     """Knowledge graph unit test"""
70     ans = kg.lookup(q)
71     assert res==ans, f"test_kg answer {ans}"
72     print("knowledge graph unit test passed")
73
74 if __name__ == "__main__":
75     test_kg()

```

To read rdf files, you can use rdflib (<https://rdflib.readthedocs.io/en/stable/>).

The default in `load_file` is to only include English names; multiple languages can be included in the list. If the language restriction is `None`, all tuples are included. Converting to strings, as done here, loses information, e.g., the language associated with the literals. If you don't want to lose information, you can use rdflib objects.

```

_____knowledgeGraph.py — (continued)_____
75 # before using do:
76 # pip install rdflib
77
78 def load_file(ts, filename, language_restriction=['en']):
79     import rdflib
80     g = rdflib.Graph()
81     g.parse(filename)
82     for (s,v,o) in g:
83         if language_restriction and isinstance(o,rdflib.term.Literal) and
84             o._language and o._language not in language_restriction:
85             pass
86         else:
87             ts.add((str(s),str(v),str(o)))
88     print(f"{len(g)} triples read. Triple store has {len(ts)} triples.")
89
90 TripleStore.load_file = load_file
91
92 ##### Test cases #####
93 ts = TripleStore()
94 #ts.load_file('http://www.wikidata.org/wiki/Special:EntityData/Q262802.nt')
95 q262802 = 'http://www.wikidata.org/entity/Q262802'
96 #res=ts.lookup((q262802, 'http://www.wikidata.org/prop/P27',Q)) # country
97     of citizenship
98 # The attributes of the object in the first answer to the above query:
99 #ts.lookup((res[0][2],Q,Q))

```

```

98 | #ts.lookup((q262802, 'http://www.wikidata.org/prop/P54',Q)) # member of
    |     sports team
99 | #ts.lookup((q262802, 'http://schema.org/name',Q))

```

## 16.2 Integrating Datalog and Triple Store

The following extends the definite clause reasoner in the previous chapter to include a built-in “triple” predicate (an atom with name “triple” and three arguments). The instances of this predicate are retrieved from the triple store. This is a simplified version of what can be done with the `semweb` library of SWI Prolog ([https://www.swi-prolog.org/pldoc/doc\\_for?object=section\(%27packages/semweb.html%27\)](https://www.swi-prolog.org/pldoc/doc_for?object=section(%27packages/semweb.html%27))). For anything serious, we suggest you use that. Note that the `semweb` library uses “`rdf`” as the predicate name, and Poole and Mackworth [2023] uses “`prop`” in Section 16.1.3 for the same predicate as “`triple`”.

```

-----knowledgeReasoning.py — Integrating Datalog and triple store-----
11 | from logicRelation import Var, Atom, Clause, KB, unify, apply
12 | from knowledgeGraph import TripleStore, sts
13 | import random
14 |
15 | class KBT(KB):
16 |     def __init__(self, triplestore, statements=[]):
17 |         self.triplestore = triplestore
18 |         KB.__init__(self, statements)
19 |
20 |     def eval_triple(self, ans, selected, remaining, indent):
21 |         query = selected.args
22 |         Q = self.triplestore.Q
23 |         pattern = tuple(Q if isinstance(e,Var) else e for e in query)
24 |         retrieved = self.triplestore.lookup(pattern)
25 |         self.display(3,indent,"eval_triple:
    |             query=",query,"pattern=",pattern,"retrieved=",retrieved)
26 |         for tr in random.sample(retrieved,len(retrieved)):
27 |             sub = unify(tr, query)
28 |             self.display(3,indent,"KB.prove:
    |                 selected=",selected,"triple=",tr,"sub=",sub)
29 |             if sub is not False:
30 |                 yield from self.prove(apply(ans,sub), apply(remaining,sub),
    |                     indent+" ")
31 |
32 | # simple test case:
33 | kbt = KBT(sts) # sts is simple triplestore from knowledgeGraph.py
34 | # kbt.ask_all([Atom('triple',('http://www.wikidata.org/entity/Q262802',
    |     Var('P'),Var('O')))])

```

The following are some larger examples from Wikidata. You must run `load_file` to load the triples related to Christine Sinclair (Q262802). Otherwise the queries won’t work.

The first query is how Christine Sinclair (Q262802) is related to Portland Thorns (Q1446672) with two hops in the knowledge graph. It is asking for a  $P$ ,  $O$  and  $P1$  such that

$$(Q262802, P, O) \& (O, P1, Q1446672)$$

```

_____knowledgeReasoning.py — (continued)_____
36 O = Var('O'); O1 = Var('O1')
37 P = Var('P')
38 P1 = Var('P1')
39 T = Var('T')
40 N = Var('N')
41 def triple(s,v,o): return Atom('triple',[s,v,o])
42 def lt(a,b): return Atom('lt',[a,b])
43
44 ts = TripleStore()
45 kbts = KBT(ts)
46 #ts.load_file('http://www.wikidata.org/wiki/Special:EntityData/Q262802.nt')
47 q262802 = 'http://www.wikidata.org/entity/Q262802'
48 # How is Christine Sinclair (Q262802) related to Portland Thorns
   (Q1446672) with 2 hops:
49 # kbts.ask_all([triple(q262802, P, O), triple(O, P1,
   'http://www.wikidata.org/entity/Q1446672') ])

```

The second is asking for the name of a team that Christine Sinclair (Q262802) played for. It is asking for a  $O$ ,  $T$  and  $N$ , where  $O$  is the reified object that gives the relationship,  $T$  is the team and  $N$  is the name of the team. Informally (with variables starting with uppercase and constants in lower case) this is

$$(q262802, p54, O) \& (O, p54, T) \& (T, name, N)$$

Notice how the reified relation 'P54' (member of sports team) is represented:

```

_____knowledgeReasoning.py — (continued)_____
51 # What is the name of a team that Christine Sinclair played for:
52 # kbts.ask_one([triple(q262802, 'http://www.wikidata.org/prop/P54',O),
   triple(O, 'http://www.wikidata.org/prop/statement/P54',T),
   triple(T, 'http://schema.org/name',N)])

```

The third asks for the name of a team that Christine Sinclair (Q262802) played for at two different start times. It is asking for a  $N$ ,  $D1$  and  $D2$ ,  $N$  is the name of the team and  $D1$  and  $D2$  are the start dates. In Wikidata, P54 is "member of sports team" and P580 is "start time".

```

_____knowledgeReasoning.py — (continued)_____
54 # The name of a team that Christine Sinclair played for at two different
   times, and the dates
55 def playedtwice(s,n,d0,d1): return Atom('playedtwice',[s,n,d0,d1])
56 S = Var('S')
57 N = Var('N')

```

```
58 D0 = Var('D0')
59 D1 = Var('D2')
60
61 kbts.add_clause(Clause(playedtwice(S,N,D0,D1), [
62     triple(S, 'http://www.wikidata.org/prop/P54', 0),
63     triple(0, 'http://www.wikidata.org/prop/statement/P54', T),
64     triple(S, 'http://www.wikidata.org/prop/P54', 01),
65     triple(01, 'http://www.wikidata.org/prop/statement/P54', T),
66     lt(0,01), # ensure different and only generated once
67     triple(T, 'http://schema.org/name', N),
68     triple(0, 'http://www.wikidata.org/prop/qualifier/P580', D0),
69     triple(01, 'http://www.wikidata.org/prop/qualifier/P580', D1)
70 ]))
71
72 # kbts.ask_all([playedtwice(q262802,N,D0,D1)])
```

## Relational Learning

### 17.1 Collaborative Filtering

The code here is based on the gradient descent algorithm for matrix factorization of Koren, Bell, and Volinsky [2009].

A rating set consists of training and test data, each a list of  $(user, item, rating)$  tuples.

```
_____relnCollFilt.py — Latent Property-based Collaborative Filtering _____  
11 import random  
12 import matplotlib.pyplot as plt  
13 import urllib.request  
14 from learnProblem import Learner  
15 from display import Displayable  
16  
17 class Rating_set(Displayable):  
18     """A rating contains:  
19     training_data: list of (user, item, rating) triples  
20     test_data: list of (user, item, rating) triples  
21     """  
22     def __init__(self, training_data, test_data):  
23         self.training_data = training_data  
24         self.test_data = test_data
```

The following is a representation of Examples 17.5-17.7 of Poole and Mackworth [2023]. This is a much smaller dataset than one would expect to work well.

```
_____relnCollFilt.py — (continued) _____  
26 grades_rs = Rating_set( # 3='A', 2='B', 1='C'  
27     [('s1','c1',3), # training data  
28     ('s2','c1',1),
```

```

29     ('s1', 'c2', 2),
30     ('s2', 'c3', 2),
31     ('s3', 'c2', 2),
32     ('s4', 'c3', 2)],
33     [('s3', 'c4', 3), # test data
34      ('s4', 'c4', 1)])

```

A CF\_learner does stochastic gradient descent to make a predictor of ratings for user-item pairs.

```

_____relnCollFilt.py — (continued) _____
36 class CF_learner(Learner):
37     def __init__(self,
38                 rating_set,          # a Rating_set
39                 step_size = 0.01,    # gradient descent step size
40                 regularization = 1.0, # L2 regularization for full dataset
41                 num_properties = 10,  # number of hidden properties
42                 property_range = 0.02 # properties are initialized to be
                                     # between
43                                     # -property_range and property_range
44                 ):
45         self.rating_set = rating_set
46         self.training_data = rating_set.training_data
47         self.test_data = self.rating_set.test_data
48         self.step_size = step_size
49         self.regularization = regularization
50         self.num_properties = num_properties
51         self.num_ratings = len(self.training_data)
52         self.ave_rating = (sum(r for (u,i,r) in self.training_data)
53                            /self.num_ratings)
54         self.users = {u for (u,i,r) in self.training_data}
55         self.items = {i for (u,i,r) in self.training_data}
56         self.user_bias = {u:0 for u in self.users}
57         self.item_bias = {i:0 for i in self.items}
58         self.user_prop = {u:[random.uniform(-property_range,property_range)
59                               for p in range(num_properties)]
60                            for u in self.users}
61         self.item_prop = {i:[random.uniform(-property_range,property_range)
62                               for p in range(num_properties)]
63                            for i in self.items}
64         # the _delta variables are the changes internal to a batch:
65         self.user_bias_delta = {u:0 for u in self.users}
66         self.item_bias_delta = {i:0 for i in self.items}
67         self.user_prop_delta = {u:[0 for p in range(num_properties)]
68                                  for u in self.users}
69         self.item_prop_delta = {i:[0 for p in range(num_properties)]
70                                  for i in self.items}
71         # zeros is used for users and items not in the training set
72         self.zeros = [0 for p in range(num_properties)]
73         self.epoch = 0
74         self.display(1, "Predict mean:" "(Ave Abs,AveSumSq)",

```

```

75         "training =",self.eval2string(self.training_data,
76         useMean=True),
        "test =",self.eval2string(self.test_data, useMean=True))

```

prediction returns the current prediction of a user on an item.

```

relnCollFilt.py — (continued)
78 def prediction(self,user,item):
79     """Returns prediction for this user on this item.
80     The use of .get() is to handle users or items in test set but not
81     in the training set.
82     """
83     if user in self.user_bias: # user in training set
84         if item in self.item_bias: # item in training set
85             return (self.ave_rating
86                     + self.user_bias[user]
87                     + self.item_bias[item]
88                     + sum([self.user_prop[user][p]*self.item_prop[item][p]
89                           for p in range(self.num_properties)]))
90         else: # training set contains user but not item
91             return (self.ave_rating + self.user_bias[user])
92     elif item in self.item_bias: # training set contains item but not
93         user
94         return self.ave_rating + self.item_bias[item]
95     else:
96         return self.ave_rating

```

learn carries out num\_epochs epochs of stochastic gradient descent with batch\_size giving the number of training examples in a batch. The number of epochs is approximately the average number of times each training data point is used. It is approximate because it processes the integral number of the batch size.

```

relnCollFilt.py — (continued)
96 def learn(self, num_epochs = 50, batch_size=1000):
97     """ do (approximately) num_epochs iterations through the dataset
98     batch_size is the size of each batch of stochastic gradient
99     gradient descent.
100     """
101     batch_size = min(batch_size, len(self.training_data))
102     batch_per_epoch = len(self.training_data) // batch_size #
103     approximate
104     num_iter = batch_per_epoch*num_epochs
105     reglz =
106         self.step_size*self.regularization*batch_size/len(self.training_data)
107         #regularization per batch
108     for i in range(num_iter):
109         if i % batch_per_epoch == 0:
110             self.epoch += 1
111             self.display(1,"Epoch", self.epoch, "(Ave Abs,AveSumSq)",

```

```

109         "training =",self.eval2string(self.training_data),
110         "test =",self.eval2string(self.test_data))
111     # determine errors for a batch
112     for (user,item,rating) in random.sample(self.training_data,
113         batch_size):
114         error = self.prediction(user,item) - rating
115         self.user_bias_delta[user] += error
116         self.item_bias_delta[item] += error
117         for p in range(self.num_properties):
118             self.user_prop_delta[user][p] +=
119                 error*self.item_prop[item][p]
120             self.item_prop_delta[item][p] +=
121                 error*self.user_prop[user][p]
122     # Update all parameters
123     for user in self.users:
124         self.user_bias[user] -=
125             (self.step_size*self.user_bias_delta[user]
126              + reglz*self.user_bias[user])
127         self.user_bias_delta[user] = 0
128         for p in range(self.num_properties):
129             self.user_prop[user][p] -=
130                 (self.step_size*self.user_prop_delta[user][p]
131                  + reglz*self.user_prop[user][p])
132             self.user_prop_delta[user][p] = 0
133     for item in self.items:
134         self.item_bias[item] -=
135             (self.step_size*self.item_bias_delta[item]
136              + reglz*self.item_bias[item])
137         self.item_bias_delta[item] = 0
138         for p in range(self.num_properties):
139             self.item_prop[item][p] -=
140                 (self.step_size*self.item_prop_delta[item][p]
141                  + reglz*self.item_prop[item][p])
142             self.item_prop_delta[item][p] = 0

```

The evaluate method evaluates current predictions on the rating set:

```

relnCollFilt.py — (continued)
137 def evaluate(self, ratings, useMean=False):
138     """returns (average_absolute_error, average_sum_squares_error) for
139         ratings
140     """
141     abs_error = 0
142     sumsq_error = 0
143     if not ratings: return (0,0)
144     for (user,item,rating) in ratings:
145         prediction = self.ave_rating if useMean else
146             self.prediction(user,item)
147         error = prediction - rating
148         abs_error += abs(error)
149         sumsq_error += error * error

```

```

148         return abs_error/len(ratings), sumsq_error/len(ratings)
149
150     def eval2string(self, *args, **nargs):
151         """returns a string form of evaluate, with fewer digits
152         """
153         (abs,ssq) = self.evaluate(*args, **nargs)
154         return f"({abs:.4f}, {ssq:.4f})"

```

Let's test the code on the grades rating set:

```

relnCollFilt.py — (continued)
156 #lg = CF_learner(grades_rs,step_size = 0.1, regularization = 0.01,
157                 num_properties = 1)
158 #lg.learn(num_epochs = 500)
159 # lg.item_bias
160 # lg.user_bias
161 # lg.plot_property(0,plot_all=True) # can you explain why?

```

**Exercise 17.1** In using `CF_learner` with `grades_rs`, does it work better with 0 properties? Is it overfitting to the data? How can overfitting be adjusted?

**Exercise 17.2** Modify the code so that `self.ave_rating` is also learned. It should start as the average rating. Should it be regularized? Does it change from the initialized value? Does it work better or worse?

**Exercise 17.3** With the Movielens 100K dataset and the batch size being the whole training set, the error go to infinity? How can this be fixed?

**Exercise 17.4** Can the regularization avoid iterating through the parameters for all users and items after a batch? Consider items that are in many batches versus those in a few or even no batches. (Warning: This is challenging to get right.)

### 17.1.1 Plotting

The `plot_predictions` method plots the cumulative distributions for each ground truth. Figure 17.1 shows a plot for the Movielens 100K dataset. Consider the `rating = 1` line. The value for  $x$  is the proportion of the predictions with predicted value  $\leq x$  when the ground truth has a rating of 1. Similarly for the other lines.

Figure 17.1 is for one run on the training data. What would you expected the test data to look like?

```

relnCollFilt.py — (continued)
162     def plot_predictions(self, examples="test"):
163         """
164         examples is either "test" or "training" or the actual examples
165         """
166         if examples == "test":
167             examples = self.test_data
168         elif examples == "training":
169             examples = self.training_data

```

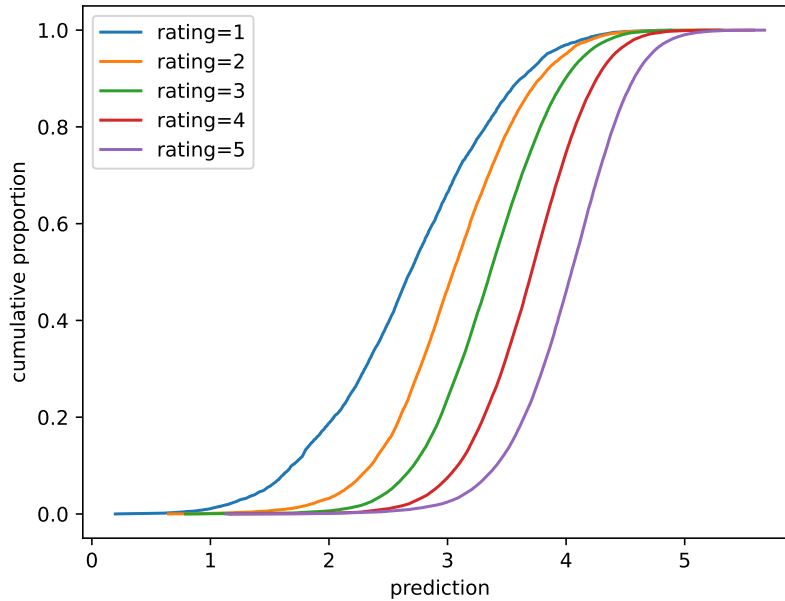

Figure 17.1: learner1.plot\_predictions(examples = "training")

```

170 plt.ion()
171 plt.xlabel("prediction")
172 plt.ylabel("cumulative proportion")
173 self.actuals = [[] for r in range(0,6)]
174 for (user,item,rating) in examples:
175     self.actuals[rating].append(self.prediction(user,item))
176 for rating in range(1,6):
177     self.actuals[rating].sort()
178     numrat=len(self.actuals[rating])
179     yvals = [i/numrat for i in range(numrat)]
180     plt.plot(self.actuals[rating], yvals,
181             label="rating="+str(rating))
181 plt.legend()
182 plt.draw()

```

The `plot_property` method plots a single latent property; see Figure 17.2. Each  $(user, item, rating)$  is plotted where the  $x$ -value is the value of the property for the user, the  $y$ -value is the value of the property for the item, and the rating is plotted at this  $(x, y)$  position. That is,  $rating$  is plotted at the  $(x, y)$  position  $(p(user), p(item))$ .

Because there are too many ratings to show, `plot_property` selects a random number of points. It is difficult to see what is going on; the `create_top_subset` method was created to show the most rated items and the users who rated the most of these. This should help visualize how the latent property helps.

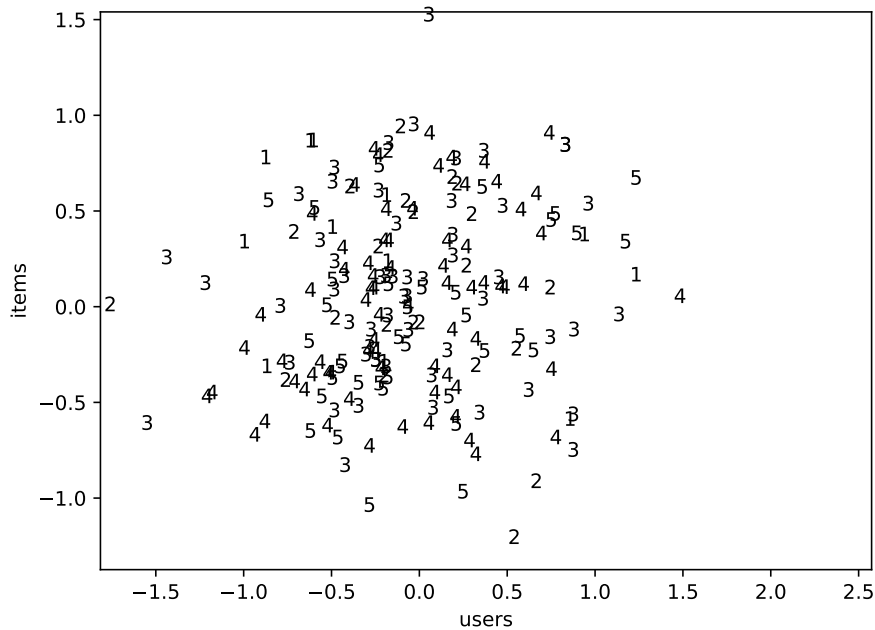

Figure 17.2: learner1.plot\_property(0) with 200 random ratings plotted. Rating  $(u, i, r)$  has  $r$  plotted a position  $(p(u), p(i))$  where  $p$  is the selected latent property.

```

relnCollFilt.py — (continued)
184 def plot_property(self,
185     p, # property
186     plot_all=False, # true if all points should be plotted
187     num_points=200 # number of random points plotted if not
        all
188     ):
189     """plot some of the user-movie ratings,
190     if plot_all is true
191     num_points is the number of points selected at random plotted.
192
193     the plot has the users on the x-axis sorted by their value on
        property p and
194     with the items on the y-axis sorted by their value on property p and
195     the ratings plotted at the corresponding x-y position.
196     """
197     plt.ion()
198     plt.xlabel("users")
199     plt.ylabel("items")
200     user_vals = [self.user_prop[u][p]
201                 for u in self.users]
202     item_vals = [self.item_prop[i][p]

```

```

203         for i in self.items]
204     plt.axis([min(user_vals)-0.02,
205             max(user_vals)+0.05,
206             min(item_vals)-0.02,
207             max(item_vals)+0.05])
208     if plot_all:
209         for (u,i,r) in self.training_data:
210             plt.text(self.user_prop[u][p],
211                    self.item_prop[i][p],
212                    str(r))
213     else:
214         for i in range(num_points):
215             (u,i,r) = random.choice(self.training_data)
216             plt.text(self.user_prop[u][p],
217                    self.item_prop[i][p],
218                    str(r))
219     plt.show()

```

## 17.1.2 Loading Rating Sets from Files and Websites

This assumes the form of the Movielens datasets Harper and Konstan [2015], available from <http://grouplens.org/datasets/movielens/>.

The Movielens datasets consist of *(user, movie, rating, timestamp)* tuples. The aim here is to predict the future from the past. Tuples before `data_split` form the training set, and those after the test set.

A rating set can be read from the Internet or read from a local file. The default is to read the Movielens 100K dataset from the Internet. It would be more efficient to save the dataset as a local file, and then set `local_file = True`, as then it will not need to download the dataset every time the program is run.

```

_____relnCollFilt.py — (continued)_____
221 class Rating_set_from_file(Rating_set):
222     def __init__(self,
223                 date_split=892000000,
224                 local_file=False,
225                 url="http://files.grouplens.org/datasets/movielens/ml-100k/u.data",
226                 file_name="u.data"):
227         self.display(1,"reading...")
228         if local_file:
229             lines = open(file_name,'r')
230         else:
231             lines = (line.decode('utf-8') for line in
232                    urllib.request.urlopen(url))
233         all_ratings = (tuple(int(e) for e in line.strip().split('\t'))
234                       for line in lines)
235         self.training_data = []
236         self.training_stats = {1:0, 2:0, 3:0, 4:0 ,5:0}
237         self.test_data = []
238         self.test_stats = {1:0, 2:0, 3:0, 4:0 ,5:0}

```

```

238     for (user,item,rating,timestamp) in all_ratings:
239         if timestamp < date_split: # rate[3] is timestamp
240             self.training_data.append((user,item,rating))
241             self.training_stats[rating] += 1
242         else:
243             self.test_data.append((user,item,rating))
244             self.test_stats[rating] += 1
245     self.display(1,"...read:", len(self.training_data),"training
        ratings and",
246                 len(self.test_data),"test ratings")
247     tr_users = {user for (user,item,rating) in self.training_data}
248     test_users = {user for (user,item,rating) in self.test_data}
249     self.display(1,"users:",len(tr_users),"training,",len(test_users),"test,",
250                len(tr_users & test_users),"in common")
251     tr_items = {item for (user,item,rating) in self.training_data}
252     test_items = {item for (user,item,rating) in self.test_data}
253     self.display(1,"items:",len(tr_items),"training,",len(test_items),"test,",
254                len(tr_items & test_items),"in common")
255     self.display(1,"Rating statistics for training set:
        ",self.training_stats)
256     self.display(1,"Rating statistics for test set: ",self.test_stats)

```

### 17.1.3 Ratings of top items and users

Sometimes it is useful to plot a property for all  $(user, item, rating)$  triples. There are too many such triples in the data set. The method `create_top_subset` creates a much smaller dataset where this makes sense. It picks the most rated items, then picks the users who have the most ratings on these items. It is designed for depicting the meaning of properties, and may not be useful for other purposes. The resulting plot is shown in Figure 17.3

```

_____relnCollFilt.py --- (continued) _____
258 class Rating_set_top_subset(Rating_set):
259
260     def __init__(self, rating_set, num_items = (20,40), num_users =
        (20,24)):
261         """Returns a subset of the ratings by picking the most rated items,
262         and then the users that have most ratings on these, and then all of
        the
263         ratings that involve these users and items.
264         num_items is (ni,si) which selects ni users at random from the top
        si users
265         num_users is (nu,su) which selects nu items at random from the top
        su items
266         """
267         (ni, si) = num_items
268         (nu, su) = num_users
269         items = {item for (user,item,rating) in rating_set.training_data}
270         item_counts = {i:0 for i in items}

```

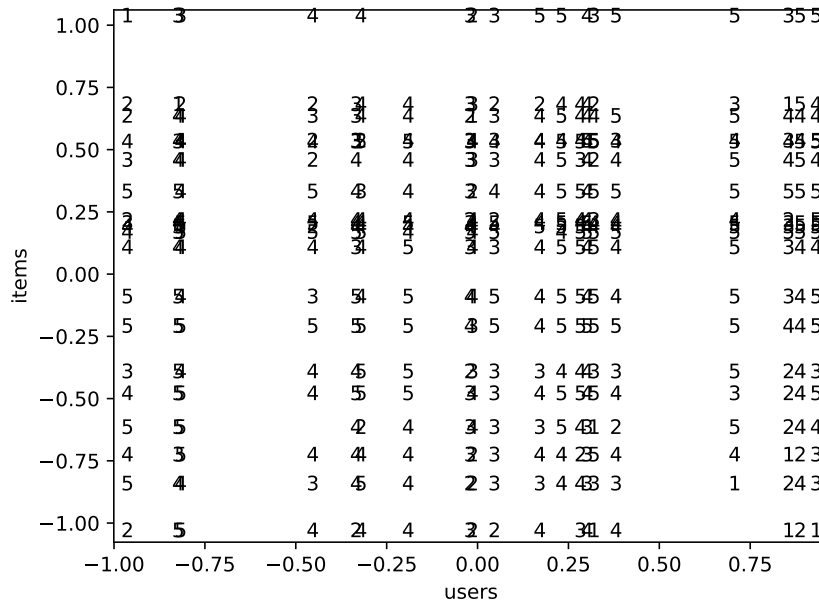

Figure 17.3: learner1.plot\_property(0) for 20 most rated items and 20 users with most ratings on these. Users and items with similar property values overwrite each other.

```

271     for (user,item,rating) in rating_set.training_data:
272         item_counts[item] += 1
273
274     items_sorted = sorted((item_counts[i],i) for i in items)
275     top_items = random.sample([item for (count, item) in
276         items_sorted[-si:]], ni)
277     set_top_items = set(top_items)
278
279     users = {user for (user,item,rating) in rating_set.training_data}
280     user_counts = {u:0 for u in users}
281     for (user,item,rating) in rating_set.training_data:
282         if item in set_top_items:
283             user_counts[user] += 1
284
285     users_sorted = sorted((user_counts[u],u) for u in users)
286     top_users = random.sample([user for (count, user) in
287         users_sorted[-su:]], nu)
288     set_top_users = set(top_users)
289
290     self.training_data = [ (user,item,rating)
291         for (user,item,rating) in rating_set.training_data
292         if user in set_top_users and item in set_top_items]

```

```

291         self.test_data = []
292
293     movielens = Rating_set_from_file()
294     learner1 = CF_learner(movielens, num_properties = 1)
295     # learner10 = CF_learner(movielens, num_properties = 10)
296     # learner1.learn(50)
297     # learner1.plot_predictions(examples = "training")
298     # learner1.plot_predictions(examples = "test")
299     # learner1.plot_property(0)
300     # movielens_subset = Rating_set_top_subset(movielens,num_items = (20,40),
301         num_users = (20,40))
302     # learner_s = CF_learner(movielens_subset, num_properties=1)
303     # learner_s.learn(1000)
304     # learner_s.plot_property(0,plot_all=True)

```

## 17.2 Relational Probabilistic Models

The following implements relational belief networks – belief networks with plates. Plates correspond to logical variables.

```

_____relnProbModels.py — Relational Probabilistic Models: belief networks with plates_____
11 from display import Displayable
12 from probGraphicalModels import BeliefNetwork
13 from variable import Variable
14 from probRC import ProbRC
15 from probFactors import Prob
16 import random
17
18 boolean = [False, True]

```

A ParVar is a parametrized random variable, which consists of the name, a list of logical variables (plates), a domain, and a position. For each assignment of an entity to each logical variable, there is a random variable in a grounding.

```

_____relnProbModels.py — (continued)_____
20 class ParVar(object):
21     """Parametrized random variable"""
22     def __init__(self, name, log_vars, domain, position=None):
23         self.name = name # string
24         self.log_vars = log_vars
25         self.domain = domain # list of values
26         self.position = position if position else (random.random(),
27             random.random())
27         self.size = len(domain)

```

The class RBN is of relational belief networks. A relational belief networks consists of a title, a set of parvariables, and a set of parfactors.

```

_____relnProbModels.py — (continued)_____
29 class RBN(Displayable):

```

```

30     def __init__(self, title, parvars, parfactors):
31         self.title = title
32         self.parvars = parvars
33         self.parfactors = parfactors
34         self.log_vars = {V for PV in parvars for V in PV.log_vars}

```

The grounding of a belief network with a population for each logical variable is a belief network, for which any of the belief network inference algorithms work.

```

_____relnProbModels.py — (continued)_____
36     def ground(self, populations, offsets=None):
37         """Ground the belief network with the populations of the logical
38             variables.
39             populations is a dictionary that maps each logical variable to the
40             list of individuals.
41             Returns a belief network representation of the grounding.
42             """
43         assert all(lv in populations for lv in self.log_vars), f"[[lv for
44             lv in self.log_vars if lv not in populations]] have no
45             population"
46         self.cps = [] # conditional probabilities in the grounding
47         self.var_dict = {} # ground variables created
48         for pp in self.parfactors:
49             self.ground_parfactor(pp, list(self.log_vars), populations, {},
50                 offsets)
51         return BeliefNetwork(self.title+"_grounded",
52             self.var_dict.values(), self.cps)
53
54     def ground_parfactor(self, parfactor, lvs, populations, context,
55         offsets):
56         """
57         parfactor is the parfactor to get instances of
58         lvs is a list of the logical variables in parfactor not assigned in
59         context
60         populations is {logical_variable: population} dictionary
61         context is a {logical_variable:value} dictionary for
62         logical_variable in parfactor
63         offsets a {loc_var:(x_offset,y_offset)} dictionary or None
64         """
65         if lvs == []:
66             if isinstance(parfactor, Prob):
67                 self.cps.append(Prob(self.ground_pvr(parfactor.child, context, offsets),
68                     [self.ground_pvr(p, context, offsets)
69                         for p in parfactor.parents],
70                     parfactor.values))
71             else:
72                 print("Parfactor not implemented for", parfactor, "of
73                     type", type(parfactor))
74         else:
75             for val in populations[lvs[0]]:

```

```

65         self.ground_parfactor(parfactor, lvs[1:], populations,
66                               {lvs[0]:val}|context, offsets)
67
68     def ground_pvr(self, prv, context, offsets):
69         """grounds a parametrized random variable with respect to a context
70         prv is a parametrized random variable
71         context is a logical_variable:value dictionary that assigns all
72         logical variables in prv
73         offsets a {loc_var:(x_offset,y_offset)} dictionary or None
74         """
75         if isinstance(prv, ParVar):
76             args = tuple(context[lv] for lv in prv.log_vars)
77             if (prv, args) in self.var_dict:
78                 return self.var_dict[(prv, args)]
79             else:
80                 new_gv = GrVar(prv, args, offsets)
81                 self.var_dict[(prv, args)] = new_gv
82                 return new_gv
83         else: # allows for non-parametrized random variables
84             return prv

```

A GrVar is a variable constructed by grounding a parametrized random variable with respect to a tuple of values for the logical variables.

relnProbModels.py — (continued)

```

84 class GrVar(Variable):
85     """Grounded Variable"""
86     def __init__(self, parvar, args, offsets = None):
87         """A grounded variable
88         parvar is the parametrized variable
89         args is a tuple of a value for each random variable
90         offsets is a map between the value and the (x,y) offsets
91         """
92         if offsets:
93             pos = sum_positions([parvar.position]+[offsets[a] for a in
94                               args])
95         else:
96             pos = sum_positions([parvar.position,
97                               (random.uniform(-0.2,0.2),random.uniform(-0.2,0.2))])
98         Variable.__init__(self, parvar.name+"("+".join(args)+")",
99                           parvar.domain, pos)
100         self.parvar= parvar
101         self.args = tuple(args)
102         self.hash_value = None
103
104     def __hash__(self):
105         if self.hash_value is None: # only hash once
106             self.hash_value = hash((self.parvar, self.args))
107         return self.hash_value
108
109     def __eq__(self, other):

```

```

107         return isinstance(other,GrVar) and self.parvar == other.parvar and
           self.args == other.args
108
109 def sum_positions(poslist):
110     (x,y) = (0,0)
111     for (xo,yo) in poslist:
112         x += xo
113         y += yo
114     return (x,y)

```

The following is a representation of Examples 17.5-17.7 of Poole and Mackworth [2023]. The plate model – represented here using grades – is shown in Figure 17.4. The observation in obs corresponds to the dataset of Figure 17.3. The grounding in grades\_gr corresponds to Figure 17.5, but also includes the Grade variables no needed to answer the query (see exercise below).

Try the commented out queries to the Python shell:

```

relnProbModels.py — (continued)
116 Int = ParVar("Intelligent", ["St"], boolean, position=(0.0,0.7))
117 Grade = ParVar("Grade", ["St","Co"], ["A", "B", "C"], position=(0.2,0.6))
118 Diff = ParVar("Difficult", ["Co"], boolean, position=(0.3,0.9))
119
120 pg = Prob(Grade, [Int, Diff],
121           [{"A": 0.1, "B":0.4, "C":0.5},
122            {"A": 0.01, "B":0.09, "C":0.9}],
123           [{"A": 0.9, "B":0.09, "C":0.01},
124            {"A": 0.5, "B":0.4, "C":0.1}])
125 pi = Prob( Int, [], [0.5, 0.5])
126 pd = Prob( Diff, [], [0.5, 0.5])
127 grades = RBN("Grades RBN", {Int, Grade, Diff}, {pg,pi,pd})
128
129 students = ["s1", "s2", "s3", "s4"]
130 st_offsets = {st:(0,-0.2*i) for (i,st) in enumerate(students)}
131 courses = ["c1", "c2", "c3", "c4"]
132 co_offsets = {co:(0.2*i,0) for (i,co) in enumerate(courses)}
133 grades_gr = grades.ground({"St": students, "Co": courses},
134                          offsets= st_offsets | co_offsets)
135
136 obs = {GrVar(Grade,["s1","c1"]):"A", GrVar(Grade,["s2","c1"]):"C",
137        GrVar(Grade,["s1","c2"]):"B",
138        GrVar(Grade,["s2","c3"]):"B", GrVar(Grade,["s3","c2"]):"B",
139        GrVar(Grade,["s4","c3"]):"B"}
140
141 # grades_rc = ProbRC(grades_gr)
142 # grades_rc.show_post({GrVar(Grade,["s1","c1"]):"A"}, fontsize=10)
143 #
144     grades_rc.show_post({GrVar(Grade,["s1","c1"]):"A",GrVar(Grade,["s2","c1"]):"C"})
145 #
146     grades_rc.show_post({GrVar(Grade,["s1","c1"]):"A",GrVar(Grade,["s2","c1"]):"C",
147                        GrVar(Grade,["s1","c2"]):"B"})
148 # grades_rc.show_post(obs, fontsize=10)

```

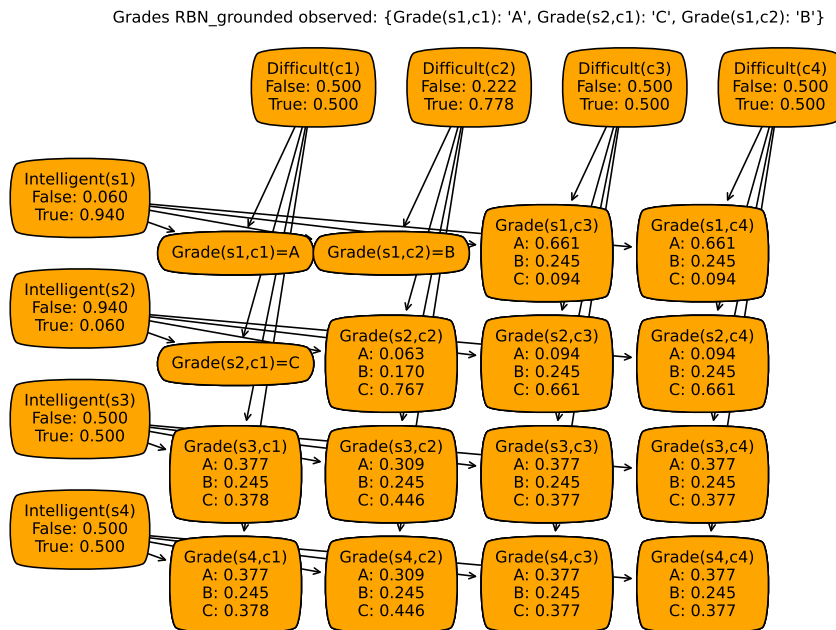

Figure 17.4: Grounded network with three observations

```

144 # grades_rc.query(GrVar(Grade,["s3","c4"]), obs)
145 # grades_rc.query(GrVar(Grade,["s4","c4"]), obs)
146 # grades_rc.query(GrVar(Int,["s3"]), obs)
147 # grades_rc.query(GrVar(Int,["s4"]), obs)

```

Figure 17.4 shows the distribution over ground variables after the 3rd `show_post` in the code above (with 3 grades observed).

**Exercise 17.5** What are advantages and disadvantages of using this formulation over using `CF_learner` with `grades_rs`? Think about overfitting, and where the parameters come from.

**Exercise 17.6** The grounding above creates a random variable for each element for each possible combination of individuals in the populations. Change it so that it only creates as many random variables as needed to answer a query. For example, for the observations and queries above, only the variables in Figure 17.5 in Poole and Mackworth [2023] need to be created.



## Version History

- 2023-12-06 Version 0.9.12: Top-down proof for Datalog (ch 15) and triple store (ch 16)
- 2023-11-21 Version 0.9.11 updated and simplified relational learning, show relational belief networks
- 2023-11-07 Version 0.9.10 Improved GUIs and test cases for decision-theoretic planning (MDPs) and reinforcement learning.
- 2023-10-6 Version 0.9.8 GUIs for search, Bayesian learning, causality and many smaller changes.
- 2023-07-31 Version 0.9.7 includes relational probabilistic models and smaller changes
- 2023-06-06 Version 0.9.6 controllers are more consistent. Many smaller changes.
- 2022-08-13 Version 0.9.5 major revisions including extra code for causality and deep learning
- 2021-07-08 Version 0.9.1 updated the CSP code to have the same representation of variables as used by the probability code
- 2021-05-13 Version 0.9.0 Major revisions to chapters 8 and 9. Introduced recursive conditioning, simplified much code. New section on multi-agent reinforcement learning.
- 2020-11-04 Version 0.8.6 simplified value iteration for MDPs.
- 2020-10-20 Version 0.8.4 planning simplified and fixed arc costs.

- 2020-07-21 Version 0.8.2 added positions and string to constraints
- 2019-09-17 Version 0.8.0 rerepresented blocks world (Section 6.1.2) due to bug found by Donato Meoli.

# Bibliography

- Chen, T. and Guestrin, C. (2016), Xgboost: A scalable tree boosting system. In *KDD '16: 22nd ACM SIGKDD International Conference on Knowledge Discovery and Data Mining*, pages 785–794, URL <https://doi.org/10.1145/2939672.2939785>. 184
- Chollet, F. (2021), *Deep Learning with Python*. Manning. 187
- Dua, D. and Graff, C. (2017), UCI machine learning repository. URL <http://archive.ics.uci.edu/ml>. 149
- Glorot, X. and Bengio, Y. (2010), Understanding the difficulty of training deep feedforward neural networks. In *Thirteenth International Conference on Artificial Intelligence and Statistics*, pages 249–256, URL <https://proceedings.mlr.press/v9/glorot10a.html>. 188
- Harper, F. M. and Konstan, J. A. (2015), The MovieLens datasets: History and context. *ACM Transactions on Interactive Intelligent Systems*, 5(4). 372
- Ke, G., Meng, Q., Finley, T., Wang, T., Chen, W., Ma, W., Ye, Q., and Liu, T.-Y. (2017), LightGBM: A highly efficient gradient boosting decision tree. In *Advances in Neural Information Processing Systems 30*. 184
- Koren, Y., Bell, R., and Volinsky, C. (2009), Matrix factorization techniques for recommender systems. *IEEE Computer*, 42(8):30–37. 365
- Lichman, M. (2013), UCI machine learning repository. URL <http://archive.ics.uci.edu/ml>. 149

Pérez, F. and Granger, B. E. (2007), IPython: a system for interactive scientific computing. *Computing in Science and Engineering*, 9(3):21–29, URL <https://ipython.org>. 10

Poole, D. L. and Mackworth, A. K. (2023), *Artificial Intelligence: foundations of computational agents*. Cambridge University Press, 3rd edition, URL <https://artint.info>. 9, 25, 27, 48, 49, 50, 76, 114, 123, 207, 211, 212, 218, 220, 290, 293, 294, 296, 310, 312, 318, 322, 325, 346, 352, 354, 356, 362, 365, 378, 379

# Index

- $\alpha$ - $\beta$  pruning, 343
- A\* search, 53
- A\* Search, 60
- action, 125
- agent, 25, 307
- argmax, 19
- assignment, 71, 201
- assumable, 119
- asynchronous value iteration, 302
- augmented feature, 160
- Bayesian network, 208
- belief network, 208
- blocks world, 128
- Boolean feature, 150
- bottom-up proof, 112
- branch-and-bound search, 64
- class
  - Action\_instance*, 142
  - Agent*, 26
  - Arc*, 42
  - Askable*, 109
  - Assumable*, 119
  - BNfromDBN*, 250
  - BeliefNetwork*, 208
  - Boosted\_dataset*, 181
  - Boosting\_learner*, 182
  - Branch\_and\_bound*, 106
  - CF\_learner*, 365
  - CPD*, 203
  - CPDrename*, 249
  - CSP*, 71
  - CSP\_from\_STRIPS*, 138
  - Clause*, 109, 350
  - Con\_solver*, 86
  - ConstantCPD*, 203
  - Constraint*, 70
  - DBN*, 249
  - DBNVEfilter*, 251
  - DBNvariable*, 247
  - DF\_Branch\_and\_bound*, 65
  - DT\_learner*, 167
  - Data\_from\_file*, 157
  - Data\_from\_files*, 159
  - Data\_set*, 151
  - Data\_set\_augmented*, 160
  - DecisionFunction*, 283
  - DecisionNetwork*, 276
  - DecisionVariable*, 275
  - Displayable*, 18
  - Dist*, 207

- Dropout\_layer*, 194
- EM\_learner*, 261
- Env\_from\_MDP*, 311
- Environment*, 26
- Evaluate*, 156
- Factor*, 201
- FactorMax*, 288
- FactorObserved*, 224
- FactorRename*, 248
- FactorSum*, 225
- Forward\_STRIPs*, 131
- FrontierPQ*, 59
- GTB\_learner*, 184
- GibbsSampling*, 234
- GrVar*, 377
- GraphicalModel*, 208
- GridDomain*, 300
- HMM*, 238
- HMMVEfilter*, 240
- HMM\_Controlled*, 241
- HMM\_Local*, 242
- HMMparticleFilter*, 244
- IFeq*, 206
- InferenceMethod*, 216, 267
- KB*, 110, 352
- KBA*, 119
- KBT*, 362
- K\_fold\_dataset*, 172
- K\_means\_learner*, 257
- Layer*, 187
- Learner*, 162
- LikelihoodWeighting*, 230
- Linear\_complete\_layer*, 189
- Linear\_complete\_layer\_RMS\_Prop*, 193
- Linear\_complete\_layer\_momentum*, 193
- Linear\_learner*, 175
- LogisticRegression*, 204
- MDP*, 289
- MDPtiny*, 293
- Magic\_sum*, 341
- Model\_based\_reinforcement\_learner*, 325
- Monster\_game\_env*, 296, 312
- NN*, 191
- Node*, 339
- NoisyOR*, 204
- POP\_node*, 142
- POP\_search\_from\_STRIPs*, 143
- ParVar*, 375
- ParticleFiltering*, 231
- Party\_env*, 310
- Path*, 45
- Planning\_problem*, 126
- Plot\_env*, 36
- Plot\_prices*, 29
- Predict*, 164
- Prob*, 205
- ProbDT*, 206
- ProbRC*, 220
- ProbSearch*, 218
- Q\_learner*, 315
- RBN*, 375
- RC\_DN*, 284
- RL\_agent*, 308
- RL\_env*, 307
- Rating\_set*, 372
- ReLU\_layer*, 190
- Regression\_STRIPs*, 135
- RejectionSampling*, 229
- Rob\_body*, 32
- Rob\_env*, 31
- Rob\_middle\_layer*, 34
- Rob\_top\_layer*, 35
- Runtime\_distribution*, 102
- SARSA*, 317
- SARSA\_LFA\_learner*, 331
- SLSearcher*, 95
- STRIPS\_domain*, 126
- SamplingInferenceMethod*, 229
- Search\_from\_CSP*, 83, 85
- Search\_problem*, 41
- Search\_problem\_from\_explicit\_graph*, 43
- Search\_with\_AC\_from\_CSP*, 94
- Searcher*, 53
- SearcherGUI*, 56
- SearcherMPP*, 62
- Show\_Localization*, 242

- Sigmoid\_layer*, 190
- SoftConstraint*, 105
- State*, 130
- Strips*, 125
- Subgoal*, 135
- TP\_agent*, 29
- TP\_env*, 28
- TabFactor*, 205
- TripleStore*, 359
- Updatable\_priority\_queue*, 101
- Utility*, 275
- UtilityTable*, 275
- VE*, 224
- VE\_DN*, 287
- Variable*, 69
- clause, 109
- collaborative filtering, 365
- comprehensions, 12
- condition, 70
- conditional probability distribution (CPD), 203
- consistency algorithms, 86
- constraint, 70
- constraint satisfaction problem, 69
- CPD (conditional probability distribution), 203
- cross validation, 171
- CSP, 69
  - consistency, 86
  - domain splitting, 89, 93
  - search, 84
  - stochastic local search, 95
- currying, 74
- datalog, 349
- dataset, 150
- DBN
  - filtering, 251
  - unrolling, 250
- DBN (dynamic belief network), 247
- debugging, 115
- decision network, 275
- decision tree learning, 167
- decision tree factors, 206
- decision variable, 275
- deep learning, 187
- display, 19
- Displayable, 18
- domain splitting, 89, 93
- Dropout, 194
- dynamic belief network (DBN), 247
  - representation, 247
- EM, 261
- environment, 25, 26, 307
- error, 155
- example, 150
- explanation, 115
- explicit graph, 43
- factor, 201, 205
- factor\_times, 225
- feature, 150, 152
- feature engineering, 149
- file
  - agentBuying.py*, 28
  - agentEnv.py*, 31
  - agentFollowTarget.py*, 38
  - agentMiddle.py*, 34
  - agentTop.py*, 35
  - agents.py*, 26
  - cspConsistency.py*, 86
  - cspConsistencyGUI.py*, 91
  - cspDFS.py*, 83
  - cspExamples.py*, 74
  - cspProblem.py*, 70
  - cspSLS.py*, 95
  - cspSearch.py*, 85
  - cspSoft.py*, 105
  - decnNetworks.py*, 275
  - display.py*, 18
  - knowledgeGraph.py*, 359
  - knowledgeReasoning.py*, 362
  - learnBayesian.py*, 253
  - learnBoosting.py*, 181
  - learnCrossValidation.py*, 172
  - learnDT.py*, 167
  - learnEM.py*, 261
  - learnKMeans.py*, 257
  - learnLinear.py*, 175

- learnNN.py*, 187
- learnNoInputs.py*, 164
- learnProblem.py*, 150
- logicAssumables.py*, 119
- logicBottomUp.py*, 112
- logicExplain.py*, 115
- logicNegation.py*, 122
- logicProblem.py*, 109
- logicRelation.py*, 349
- logicTopDown.py*, 114
- masLearn.py*, 344
- masMiniMax.py*, 342
- masProblem.py*, 339
- mdpExamples.py*, 290
- mdpGUI.py*, 300
- mdpProblem.py*, 289
- probCounterfactual.py*, 269
- probDBN.py*, 247
- probDo.py*, 267
- probExamples.py*, 210
- probFactors.py*, 201
- probGraphicalModels.py*, 208
- probHMM.py*, 238
- probLocalization.py*, 241
- probRC.py*, 218
- probStochSim.py*, 227
- probVE.py*, 224
- pythonDemo.py*, 13
- relnCollFilt.py*, 365
- relnExamples.py*, 352
- relnProbModels.py*, 375
- rlExamples.py*, 310
- rlFeatures.py*, 331
- rlGUI.py*, 334
- rlGameFeature.py*, 328
- rlModelLearner.py*, 325
- rlProblem.py*, 307
- rlQExperienceReplay.py*, 320
- rlQLearner.py*, 315
- rlStochasticPolicy.py*, 322
- searchBranchAndBound.py*, 65
- searchExample.py*, 47
- searchGUI.py*, 56
- searchGeneric.py*, 53
- searchGrid.py*, 63
- searchMPP.py*, 62
- searchProblem.py*, 41
- searchTest.py*, 66
- stripsCSPPlanner.py*, 138
- stripsForwardPlanner.py*, 130
- stripsHeuristic.py*, 133
- stripsPOP.py*, 142
- stripsProblem.py*, 125
- stripsRegressionPlanner.py*, 135
- utilities.py*, 19
- variable.py*, 69
- filtering, 240, 244
  - DBN, 251
- flip, 20
- forward planning, 130
- frange, 152
- ftype, 152
- game, 339
- Gibbs sampling, 234
- graphical model, 208
- heuristic planning, 132, 137
- hidden Markov model, 238
- hierarchical controller, 31
- HMM
  - exact filtering, 240
  - particle filtering, 244
- HMM (hidden Markov models), 238
- importance sampling, 231
- interact
  - proofs, 116
- ipython, 10
- k-means, 257
- kernel, 160
- knowledge base, 110
- knowledge graph, 359
- learner, 162
- learning, 149–199, 253–265, 307–338, 365–375
  - cross validation, 171
  - decision tree, 167
  - deep, 187–199

- deep learning, 187
- EM, 261
- k-means, 257
- linear regression, 175
- linear classification, 175
- neural network, 187
- no inputs, 163
- reinforcement, 307–338
- relational, 365
- supervised, 149–186
- with uncertainty, 253–265
- LightGBM, 184
- likelihood weighting, 230
- linear regression, 175
- linear classification, 175
- localization, 241
- logic program, 349
- logistic regression, 203
- logit, 176, 177
- loss, 155
  
- magic square, 340
- magic-sum game, 340
- Markov Chain Monte Carlo, 234
- Markov decision process, 289
- max\_display\_level, 19
- MCMC, 234
- MDP, 289, 311
  - GUI, 300
- method
  - consistent*, 72
  - holds*, 71
  - maxh*, 133
  - zero*, 131
- minimax, 339
- minimax algorithm, 342
- minsets, 120
- model-based reinforcement learner, 324
- multiagent system, 339
- multiple path pruning, 62
  
- n-queens problem, 82
- naive search probabilistic inference, 218
  
- naughts and crosses, 340
- neural network, 187
- noisy-or, 204
- NotImplementedError, 26
  
- partial-order planner, 142
- particle filtering, 231
  - HMMs, 244
- planning, 125–147, 275–306
  - CSP, 138
  - decision network, 275
  - forward, 130
  - MDP, 289
  - partial order, 142
  - regression, 135
  - with certainty, 125–147
  - with learning, 324
  - with uncertainty, 275–306
- plotting
  - agents in time, 29
  - reinforcement learning, 309
  - robot environment, 36
  - run-time distribution, 102
  - stochastic simulation, 236
- predictor, 155
- Prob, 205
- probabilistic inference methods, 216
- probability, 201
- proof
  - bottom-up, 112
  - explanation, 115
  - top-down, 114, 354
- proposition, 109
- Python, 9
  
- Q learning, 315
- query, 216
- queryD0, 267
  
- RC, 220, 284
- recursive conditioning, 220
- recursive conditioning (RC), 220
- recursive conditioning for decision networks, 284
- regression planning, 135
- reinforcement learning, 307–338

- environment, 307
- feature-based, 327
- model-based, 324
- Q-learning, 315
- rejection sampling, 229
- relational learning, 365
- relations, 349
- ReLU, 190
- resampling, 232
- robot
  - body, 32
  - environment, 31
  - middle layer, 34
  - plotting, 36
  - top layer, 35
- robot delivery domain, 126
- run time, 16
- runtime distribution, 102
- sampling, 227
  - importance sampling, 231
  - belief networks, 229
  - likelihood weighting, 230
  - particle filtering, 231
  - rejection, 229
- SARSA, 317
- scope, 70
- search, 41
  - A\*, 53
  - branch-and-bound, 64
  - multiple path pruning, 62
- search\_with\_any\_conflict, 97
- search\_with\_var\_pq, 99
- show, 72, 209
- sigmoid, 176
- softmax, 177
- stochastic local search, 95
  - any-conflict, 97
  - two-stage choice, 98
- stochastic simulation, 227
- tabular factor, 205
- test
  - SLS, 103
- tic-tac-toe, 340
- top-down proof, 114, 354
- triple store, 359, 362
- uncertainty, 201
- unification, 351, 352
- unit test, 21, 61, 82, 113, 114, 116
- unrolling
  - DBN, 250
- updatable priority queue, 101
- utility, 275
- utility table, 275
- value iteration, 299
- variable, 69
- variable elimination (VE), 224
- variable elimination for decision net-works, 287
- VE, 224
- XGBoost, 184
- yield, 14